

Helen & Tayloe Murphy Hall Westmoreland State Park



Conditions for use of Murphy Hall

- The rental period is firmly from 8 a.m. – 10 p.m.
- In order to serve alcohol at an event, an ABC banquet permit must be obtained and presented to park prior to event. Alcohol may only be present in building itself and rear fenced in area. Application for a one day banquet license may be obtained from the Virginia Alcohol Beverage Control Board by contacting a local ABC store or the agency website at www.abc.state.va.us/licensing.
- Amplified music will not be allowed after 8 p.m. and must be appropriate at reasonable volume levels. Music must not be able to be heard from Campground A.
- Parking fees are included for up to 45 vehicles in the hall's designated parking area. There will be a parking fee applied for vehicles exceeding this allowance.
- There is no smoking permitted inside Murphy Hall. There are ash cans located outside for your smoking convenience.
- Decorations are allowed as long as they do not damage Murphy Hall in anyway and are removed at the end of the event.
- For weddings and other events, birdseed and bubbles are appropriate. We **do not** allow **sparklers or fireworks** of any kind, **rice, glitter, balloons, or silk flowers**.
- Candles may be used for decorating as long they are protected in globes or similar manner and we are not under a fire ban.
- Animals are not allowed in the hall with the exception of a service animal.
- Tables and chairs are provided for your convenience but set-up is not included in the rental fee. Interior tables and chairs are not for outside use. We can offer advice on set-ups and layouts and provide information on rental companies for exterior chairs, etc.
- All caterers or vendors contracted must be licensed and have liability insurance.
- At the end of event, clean the facility and remove your belongings. Empty trash cans, wash dishes, remove decorations, sweep floors, and mop spills. All waste garbage shall be removed from the building and placed in dumpster. The building must be vacated by all at 10 p.m.
- The person renting facility will be responsible for all guest's actions, vendors, and the care of the facility.
- Do not park in front of the building. For unloading and loading, there is a convenient service entrance on side of building.
- A special use permit with a fee of \$25.00 must be submitted to the park prior to the event. Please outline the daily activities that will take place, any special or extraordinary conditions. The Park Manager will approve, disapprove or modify.
- There is no fee for using the field behind Visitor Center for ceremonies. However this must be requested in special use permit with details. Parking at the Visitor Center is for public use at all times.

Reservations

To reserve this day-use facility, call the Customer Service Center at **1-800-933-7275**
Reservations can be made up to 11 months in advance.

Reservations must be paid in full within 14 days of the date the reservation is made.

Special Use permits are handled separately by park.



.....

Westmoreland State Park

145 Cliff Road
Montross, VA 22520
(804) 493-8821

For reservations, please call 1-800-933-7275



.....

www.virginiastateparks.gov

Helen and Tayloe Murphy Hall at Westmoreland State Park

Features

Kitchen:

- ◇ 2 large stainless steel prep tables
- ◇ Ice maker
- ◇ Coffee makers
- ◇ 2-door upright refrigerator and upright freezer
- ◇ 2 conventional ovens and convection oven
- ◇ 2 dishwashers
- ◇ Steam table
- ◇ 3 compartment commercial sink
- ◇ Microwave

Furniture:

- ◇ 120 Beige vinyl padded folding chairs
- ◇ 30 (18" x 60") rectangle tables
- ◇ 18 (30" x 72") rectangle tables
- ◇ 12 (60") round tables
- *(linens not provided)

Wireless internet and audio/visual equipment available

Caterers and Vendors List available



Design and Layout

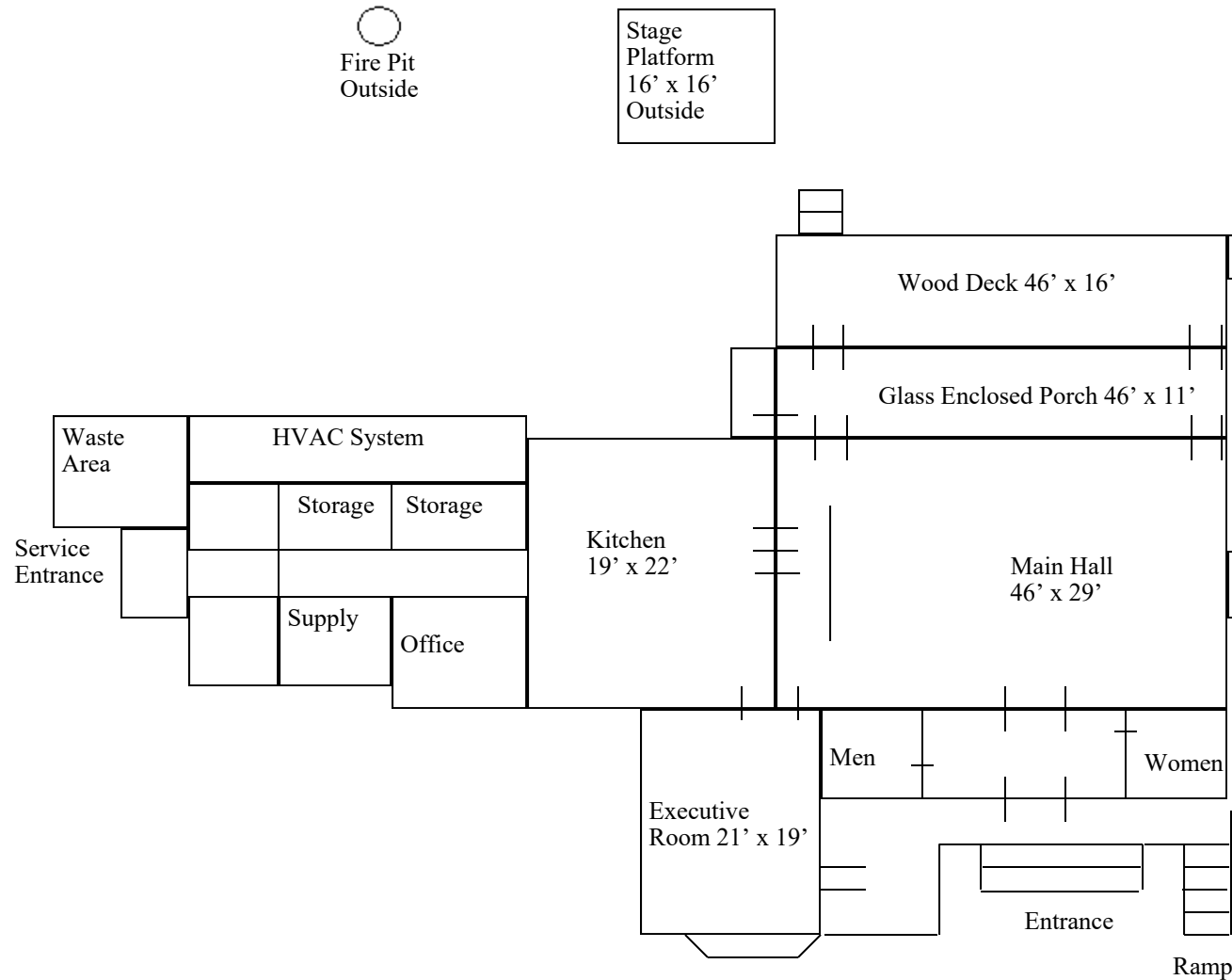

Drawing Is Not To Scale But
Dimensions Are Correct

Rates

Monday-Thursday 8 a.m. - 10 p.m.
\$750.00 per day

Friday-Sunday 8 a.m. - 10 p.m.
\$1,000.00 per day

No additional day discounts

Wedding Package \$2400.00

Includes:

Friday 10 a.m. - 10 p.m.

Saturday 8 a.m. - 10 p.m.

Sunday 9 a.m. - 2 p.m.

Special Use Permit \$25.00

Note:

- **Comfortable seating capacity for Main Hall: 72**
- **Maximum comfortable indoor seating: 100**

Call the Park to make an appointment to tour the facility.