

# Appendices

**Appendix I:**  
**Additional Information**  
**and Sample Sources**

## Appendix I: Additional information and Sample Source

For Information or Samples	Contact
Brochures	Greenway and trail organizations
Business plans	Small business development centers
By-laws	Greenway and trail organizations
Conservation easements	Local land trusts or conservancies, VOF
Design specifications	AASHTO
Environmental assessment forms	DEQ
Feasibility studies	DCR
Intergovernmental cooperation agreements and resolutions	PDCs, DCR
List of existing rail-trails	VDOT, Rail Transportation Division
List of railroads	Rails-to-Trails Conservancy
Long term lease agreements	Local land trusts or conservancies
Scenic resource inventory tools	Scenic America, USFS
Suppliers of recycled building materials	DEQ, Waste Division

# **Appendix II: Sample Partner Profile**

## Appendix II: Sample Partner Profile

This sample survey was developed by Jenkins & Quinn for the Cambria County Conservation and Recreation Authority.

- Distribute to key contacts
- Take to interviews with key informants
- Provide copies at initial public meetings

### Partner Profile

1. Name \_\_\_\_\_  
Address: \_\_\_\_\_  
Telephone: \_\_\_\_\_
2. Are you a municipal official? \_\_\_\_ Yes \_\_\_\_ No  
If yes, title: \_\_\_\_\_
3. Do you feel that people using a trail through your community would have a positive or negative effect on both your property and the area in general?  
\_\_\_\_ Positive \_\_\_\_ Negative
1. Do you think business opportunities related to the trail would develop? \_\_\_\_ Yes \_\_\_\_ No
2. What do you see as your municipality's role in assisting trail development? (Check as many as you think may apply.)
3. \_\_\_\_ preventative maintenance
4. \_\_\_\_ \* capital improvements
5. \_\_\_\_ refuse removal
6. \_\_\_\_ use of community recreation funds
7. \_\_\_\_ police protection
8. \_\_\_\_ other \_\_\_\_\_
9. Do you think your community is interested in attracting visitors, such as trail users, to your area? \_\_\_\_ Yes \_\_\_\_ No
10. Is there an active organization or person in your community who is recreation or trail oriented?
11. Is there a person in your community who is familiar with the general history of your area, including the history of the railroad or the canal in the vicinity of the trail?
12. Please use the space below for writing any additional comments. Thank you!

Source: Pennsylvania Greenways Partnership

**Appendix III:  
Sample Permission  
Form and  
Liability Waiver**

### Appendix III: Sample Permission Form and Liability Waiver

This is a sample for informational purposes only. Check with your own legal counsel for an instrument appropriate to your needs. Landowners such as utility companies may have a standard form for their own use. Each individual should sign a separate release form. Parent or guardian must sign for persons under age 18. Provide the landowner with your address and phone number. Provide description of any vehicles which will be used on the property.

#### Release and Permission Form

I (Name), \_\_\_\_\_, intending to be legally bound, do hereby waive for myself and anyone claiming through me, my right to sue (Landowner) \_\_\_\_\_, their heirs, successors, administrators and assigns, for personal injury and/or property damage incurred while on the property of (Landowner) \_\_\_\_\_.

This release is also intended to preclude the parties and their heirs, executors, administrators, successors and assigns from joining (Landowner) \_\_\_\_\_ as an additional defendant in any action.

This waiver is given in consideration for permission for the party named herein to enter upon the lands of (Landowner) \_\_\_\_\_ during the time period from (Date) \_\_\_\_\_ to (Date) \_\_\_\_\_.

Signed, this \_\_\_\_\_ day of \_\_\_\_\_, 1999.

(Signature) \_\_\_\_\_

(Witness) \_\_\_\_\_

*(Signature of parent or guardian if person is under 18 years of age)*

**Appendix IV:  
Sample Trail User  
Survey**



## Appendix IV: Sample Trail User Survey

Based on a form developed by the York County Rail Trail Authority. Provide a distribution box, collection box and firm writing surface. Locate in area sheltered from the weather. Collect and re-supply weekly. Compile results monthly or seasonally.

### Trail User Survey

Please take a few minutes to give us some helpful information. Thank you for your cooperation.

Today's date: \_\_\_\_\_

I was on the trail from \_\_\_\_\_ am/pm to \_\_\_\_\_ am/pm

I/We used the trail to:

\_\_\_\_ run \_\_\_\_ bike \_\_\_\_ hike/walk \_\_\_\_ ride horseback  
other (Please describe: \_\_\_\_\_)

I/We use the trail:

\_\_\_\_ for the first time today \_\_\_\_ daily \_\_\_\_ weekly  
\_\_\_\_ monthly \_\_\_\_ seasonally \_\_\_\_ during special events.

How long did it take you to get to the trail today? \_\_\_\_\_

How many miles did you travel to get to the trail? \_\_\_\_\_

Did you stop for purchases along the way such as rooms, meals, supplies?

Merchant Location: \_\_\_\_\_

Item or service purchased: \_\_\_\_\_

Amount spent: \_\_\_\_\_

Where did you start on the trail? \_\_\_\_\_

Where did you end or how far did you go before returning to start? \_\_\_\_\_

Number in your party: \_\_\_\_\_

Please indicate the number of trail users by age group that were in your party today: \_\_\_\_\_

### Trail User Survey (continued)

Male: \_\_\_\_ 0-5 \_\_\_\_ 6-12 \_\_\_\_ 13-18 \_\_\_\_ 19-29  
\_\_\_\_ 30-39 \_\_\_\_ 40-49 \_\_\_\_ 50-59 \_\_\_\_ 60+

Female: \_\_\_\_ 0-5 \_\_\_\_ 6-12 \_\_\_\_ 13-18 \_\_\_\_ 19-29  
\_\_\_\_ 30-39 \_\_\_\_ 40-49 \_\_\_\_ 50-59 \_\_\_\_ 60+

Trail conditions were:

\_\_\_\_ Excellent \_\_\_\_ Good \_\_\_\_ Fair \_\_\_\_ Poor

Describe what you liked most and least about your trail experience: \_\_\_\_\_

Would you be interested in helping on projects or activities related to the trail? If so, Please provide your name, address, phone number, and particular interest, if any: \_\_\_\_\_

Name: \_\_\_\_\_

Telephone: \_\_\_\_\_

Address: \_\_\_\_\_

Municipality: \_\_\_\_\_ State: \_\_\_\_\_ Zip: \_\_\_\_\_

Interests: \_\_\_\_\_

**Appendix V·**  
**A Community Value**  
**Survey**

# A Community Values Survey

Which of the following open space, transportation, recreation, and/or environmental resource issues do you believe are most important? (Please indicate a maximum of three issues, ranking them from 1 to 3, with 1 being the most important.)

- A. Agriculture preservation
- B. Open space conservation
- C. Protection of historic buildings and sites
- D. Natural Resources protection (e.g., groundwater, floodplains, wildlife habitat, important woodlands)
- E. Opportunities for passive recreation (e.g., trails, scenic views)
- F. Availability of active recreation facilities (e.g., areas for field and court sports, etc.)
- G. Alternative modes of transportation (such as walking trails and safe bicycle facilities throughout the community) which reduce reliance on motor vehicles
- H. Other: \_\_\_\_\_

2. The township plans to use several means to achieve its open space and recreation goals including donation, purchase, and regulation. In some cases, spending township funds may be the most effective approach. Assuming the funds were clearly marked for the stated purpose, would you be willing to have your current municipal taxes matched with grant funds to support the following? (Please indicate your choices with a X.)
- A. Acquire open space

- B. Acquire trail easements or rights-of-way
- C. Purchase land for park and recreation facilities
- D. Construct trails throughout the community to provide alternative forms of transportation and recreation
- E. Develop park facilities on existing township lands
- F. Operate active recreation programs (e.g., youth leagues)
- G. Operate community programs (e.g., community fairs, parades, cultural events)
- H. Other: \_\_\_\_\_

- 2A. Would you be willing to pay increased municipal taxes to support the items you indicated a willingness to support above?

Yes

No

3. How well, in your opinion, is the township addressing the following issues? (Indicate one of the following responses for each category: Satisfied, Insufficient Twp. action/regulation, Twp is overly involved, No Opinion/Inadequate Information.)
- A. Environmental resource protection
  - B. Historic resource protection
  - C. Conservation of open space
  - D. Provision of, and access to, recreation facilities and programs
  - E. Protection of existing trail network

Source: Brandywine Conservancy

F. Provision of trails for recreation purposes or as alternative forms of transportation

4. Where do you generally participate in recreational activities? (Please check as many as apply.)

At home                      At school  
At work place              Along the existing trails in the township.

On trails provided by \_\_\_\_\_

At local parks; please specify here  
\_\_\_\_\_

At private recreational sites (e.g., the YMCA, spas, athletic clubs); please specify which sites.  
\_\_\_\_\_

Other: \_\_\_\_\_

5. For each of the following recreational activities, please indicate those in which you and members of your household currently participate: Please also note those activities for which you would support actions to make more facilities available. (Place a check next to each activity that applies.)

- A. Sight-seeing or pleasure driving
- B. Walking/Hiking
- C. Jogging
- D. Nature enjoyment/contemplation
- E. Fishing
- F. Swimming
- G. Boating
- H. Canoeing
- I. Field sports (e.g., softball, baseball, football, soccer)
- J. Tennis
- K. Basketball
- L. Volleyball
- M. Bicycling
- N. Winter sports (e.g., ice skating, cross-country skiing)
- O. Camping
- P. Picnicking
- Q. Golf
- R. Horseback riding
- S. Other equestrian activities
- T. Community recreational programs
- U. Other: \_\_\_\_\_

6. What is the principal use of your property? (Check only one.)

Residence only \_\_\_\_\_ Farm \_\_\_\_\_  
Office \_\_\_\_\_ Commercial \_\_\_\_\_

Investment (including residence(s) rented to another)  
Industrial/Manufacturing

Other: \_\_\_\_\_

7. Approximately how large is your property? (Check only one)

- Less than 1 acre
- 1—2 acres
- 3—5 acres
- 6—10 acres
- 11—50 acres
- More than 50 acres

8. Please indicate the type of dwelling in which you live.  
Single-family detached house

Twin, duplex, or double

Multiunit building (e.g., apartment, townhouse, condominium)

Mobile home

Nonresident property owner

Other: \_\_\_\_\_

9. How long have you lived in the township?

- Less than 1 year
- 1—5 years
- 5—10 years
- 10—25 years
- More than 25 years
- Nonresident property owner

10. Would a local network of trails, linked to recreation areas and/or schools, work, or commercial areas make it easier for you and/or your family to travel to local destinations or participate in recreation activities?

Yes                      No

If yes, please indicate the types of trail(s) you would prefer:

Walking/hiking

Horseback

Bicycle (pedal)

Other \_\_\_\_\_

11. Please tally the number of persons in your household in each of the age groups below. Enter the number of persons in your household in that person's age group. Also, would you circle the mark for the person or persons who is (are) completing this form?

Males

Females

Age Groups

0—5 years

6—11 years

12—18 years

19—45 years

45—65 years

Over 65 years

12. If trails are created in \_\_\_\_\_ Township, what means would you prefer be used? Check all that you feel are appropriate.

- Create trails beside existing roads
- Create trails on former rail corridors
- Create trails on private property with owner's permission
- Require trails to be created as part of the subdivision process
- Other means?

13. For those members of your household currently working, where is/are their place(s) of employment? (Please indicate one place of employment for each adult working.)

Work at home/farm

Work inside the township

Work outside the township. If outside the township, please give location:

\_\_\_\_\_

**Appendix VI:  
Trail Use Rules and  
Regulations Guidelines**

## **Appendix VI:**

### **Trail Use Rules and Regulations Guidelines**

Trail use rules and regulations clarify what is expected of users and will vary greatly depending on the nature of terrain, facilities, and user groups. Consider the following in all cases:

- Give reasons for the rules
- Provide a brief statement of the type of trail experience sought
- Print rules in brochures and on maps
- Post regulations prominently at trail heads

Rules and regulations should address the following:

- Trail uses permitted or prohibited
- Hours of operation (usually from dusk to dawn)
- Trash policy (usually Carry In, Carry Out)
- Fire policy (if, where, and when fires are permissible)
- Wildlife protection policy (usually do not collect or disturb wildlife)
- Use limitation (usually stay on the trail and stay out of marked sensitive areas)
- Speed limit (for bicycles and motorized vehicles)
- Lane usage (for multi-use trail) or direction of travel (for one-way loops)
- Pet walking policy (usually dogs must be on leash at all times and curb your dog)

# **Appendix VII: Trail Assessment Form**



## Appendix VII: Trail Assessment Form

- Train volunteers to use this form by assessing a section together
- Divide the trail into tenth mile segments and mark with stakes
- Document with photos before and after improvements

### Trail Assessment Form

Date: \_\_\_\_\_

Segment: \_\_\_\_\_

Gradient: \_\_\_\_\_

Trail Surface Material: \_\_\_\_\_

Width: \_\_\_\_\_

Height of overhanging vegetation: \_\_\_\_\_

Condition of trail surface: \_\_\_\_\_

(rough, smooth, level, uneven, pitted, rutted)

Drainage:   Draining onto or across trail bed \_\_\_\_\_

              Draining off trail bed \_\_\_\_\_

              Water standing on trail bed \_\_\_\_\_

Bridges and culverts: \_\_\_\_\_

(list size, condition, apparent effectiveness)

Utility Crossings: \_\_\_\_\_

(underground, above ground)

Road and railroad crossings: \_\_\_\_\_

(describe access, parking, sight lines, general appearance)

Adjacent land use: \_\_\_\_\_

(farm, forest, residence, industrial, commercial, other)

Potential environmental hazards: \_\_\_\_\_

(dumping, tanks)

Potential attractive nuisances: \_\_\_\_\_

(cliffs, cellar holes, wells, towers, abandoned buildings)

Potential positive attractions: \_\_\_\_\_

(vistas, overlooks, historic sites, cultural sites)

**Appendix VIII:  
Model Easement  
for a Trail**

# Mod 1 Easement for a Trail

THIS GRANT OF EASEMENT AND DECLARATION OF RESTRICTIVE COVENANTS, hereinafter referred to as the "Easement" made the day of \_\_\_\_\_ in the year of our Lord One Thousand Nine Hundred and Ninety-\_\_\_\_ (199\_).

BETWEEN \_\_\_\_\_, (husband and wife) (single man) (single woman), having an address of \_\_\_\_\_, \_\_\_\_\_, party of the first part, hereinafter called "Grantor", \_\_\_\_\_

AND \_\_\_\_\_ TOWNSHIP OF \_\_\_\_\_, party of the second part, hereinafter called "Grantee,"

## WITNESSETH:

WHEREAS, Grantor is the owner of certain tracts of ground located in Township, County, Commonwealth of Pennsylvania, containing acres of land, more or less, hereinafter called the "Trail Easement Area", which includes the following parcels; as shown on a plan entitled \_\_\_\_\_, dated \_\_\_\_\_, 199\_\_, last revised \_\_\_\_\_, 199\_\_, prepared for \_\_\_\_\_, by \_\_\_\_\_, and further revised on \_\_\_\_\_, attached hereto and made a part hereof as Exhibit "A", and as described by legal descriptions, attached hereto and made a part hereof as Exhibit "B"; and

WHEREAS, the trail easement area contains \_\_\_\_\_ feet/miles of public trail(s) which, by this Easement, will be available for outdoor recreation and transportation by and the education of the general public; and

WHEREAS, the Trail Easement Area contains greater than \_\_\_\_\_ miles of frontage along \_\_\_\_\_ Road, and \_\_\_\_\_ Road, and the public travelling these roads are afforded scenic views of the forestlands, grasslands, farm fields, and wetlands, whose beauty and open character shall be available for outdoor recreation and transportation by and the education of the general public by this Easement; and

WHEREAS, the \_\_\_\_\_ Township Comprehensive Plan, adopted in 19\_\_, sets forth general community goals, which include ... [Indicate here any goal which would directly or indirectly relate to the development of the trails system]; and

WHEREAS, the \_\_\_\_\_ Township Zoning Ordinance, adopted in 19\_\_, defines community objectives which include "Securing and protecting pedestrian and non-motorized transportation facilities consistent with the transportation plan and trails map..." and to this end the township requires dedication of land for transportation and recreation purposes; and

WHEREAS, Grantor further intends, as owner of the Property, to convey to Grantee the right to preserve and protect the Recreation and Transportation values of the Trail Easement Area in perpetuity; and

WHEREAS, Grantee is a publicly-supported, tax-exempt non-profit organization, qualified under Section 501(c)3 and 170(h) of the Internal Revenue Code, whose primary purpose is the.... ; and

WHEREAS, Grantee agrees by accepting this Easement to honor the intentions of Grantor stated herein and to preserve and protect in perpetuity the Recreation and Transportation Values of the Trail Easement Area for the



Source: Brandywine Conservancy

benefit of this generation and generations to come.

NOW THEREFORE, for and in consideration of the above and the mutual covenants, terms, conditions, restrictions, and promises herein contained, pursuant to the laws of \_\_\_[state]\_\_\_ and in particular \_\_\_[specific statutory authority]\_\_\_, and for the further consideration of the sum of Five Dollars (\$5.00), lawful money of the United States of America, in hand paid by Grantee to Grantor, the receipt of which is hereby acknowledged, the parties hereto, intending to be legally bound, do hereby mutually agree, grant, convey, and declare as follows:

### 1. STATEMENT OF GRANT

Grantor hereby voluntarily, unconditionally and absolutely grants and conveys unto Grantee, its successors and assigns, an Easement in Gross and a Declaration of Restrictive Covenants, in perpetuity, over the Trail Easement Area, as more particularly hereinafter set forth exclusively for the purposes of preserving and protecting the present natural, scenic, open space, educational, and recreation and transportation values of the Trail Easement Area (such purposes hereinafter referred to as the "Recreation and Transportation Purposes"). Grantee hereby accepts the Easement and agrees to hold it exclusively for such Recreation and Transportation Purposes.

### 2. PUBLIC ACCESS

In furtherance of the Transportation and Recreation Purposes of this Easement set forth in Paragraph 1 above, Grantor hereby declares and covenants that the general public shall have and be allowed regular access to the Trail Easement Area for the transportation and recreation scientific, and educational purposes described in sub-paragraph A and subject to the limitations contained in sub-paragraphs B, C, and D of this Paragraph 2.

As used herein, Trail is defined as: A corridor of at least ten (10) feet in width through which passes, or will pass, a trail as part of the \_\_\_\_\_ Township Comprehensive Trail System or as otherwise authorized by the Township. A trail is to serve transportation and recreation functions for one or more of the following: walkers, runners, bicyclists, horseback riders, and cross-country skiers; trails shall exclude all motorized vehicles except as authorized by the Township for maintenance, management and emergency purposes. Trail Easement Area is defined as: the area (a minimum of twenty (20) feet wide) that contains the trail and is restricted from development which would inhibit the use of the trail.

A. The public shall be permitted access to the "Trail Easement Area", as shown on Exhibit "A", for the following activities, except to the extent that Grantee may determine that such activities are inconsistent with the Conservation Purposes for which this Easement is granted:

(i) Nature study and scientific research, including bird watching and the study of fauna and flora, supervised by an organization described in Section 170(h)(3) of the Internal Revenue Code

- (ii) Horseback riding;
- (iii) Cross-country skiing;
- (iv) Hiking, biking and jogging; and
- (v) Painting, sketching, and photography.

B. Public access to the Trail Easement Area shall be restricted to the "Trail Easement Area" as shown on Exhibit "A". Grantee retains the right, as it may deem necessary, in order to preserve and protect the Transportation and Recreation Values of the Trail Easement Area and the Transportation and Recreation Purposes to repair the Trail Easement Area, relocate the Trail within the Trail Easement Area, or temporarily prohibit public access to the Trail Easement Area.

C. The activities described in sub-paragraph A of this Paragraph 2 shall be conducted in such a manner as to preserve and protect the Transportation and Recreation Values of the Trail Easement Area, and in this connection the following specific limitations shall apply with respect to use of the Trail Easement Area by the general public and shall be enforceable by Grantor and/or Grantee:

(i) Use of any motorized vehicle or similar mechanical means of locomotion, including automobiles, motorcycles, snowmobiles, or other all-terrain vehicles shall be prohibited;

(ii) Smoking of tobacco or other substances, or lighting of fires of any kind shall be prohibited;

(iii) Consumption of alcoholic beverages or use of any kind of stimulant or drug shall be prohibited;

(iv) Trapping or hunting with firearms, bow and arrow, or any other form of arms or weapons shall be prohibited; and

(v) Overnight camping or sleeping shall be prohibited.

Grantee shall have the right to impose any additional limitations with respect to the Trail Easement Area, as it deems necessary or appropriate in order to preserve and protect the Transportation and Recreation Values of the Trail Easement Area and the Transportation and Recreation Purposes for which this Easement is donated.

D. Grantee shall have the right to require Grantor to keep the Trail Easement Area free from obstructions which prevent reasonable pedestrian (and equestrian) access to and along the Trail Easement Area including but not limited to structures, fences and fallen trees.

### 3. NOTICE

All notices, consents, approvals, or other communication hereunder shall be in writing and shall be deemed properly given if sent by U.S. certified mail, return receipt requested, addressed to the appropriate party or successor in interest, at the address most recently provided.

### 4. PROHIBITION OF PUBLIC ACCESS

Nothing herein shall be construed as a grant to the general public, or to a person or persons, the right to enter upon any part of the Grantor's property other than as described in Paragraphs 2, herein. Grantor reserves unto themselves and its successors in title to the Trail Easement

Area, all rights, privileges, powers, and immunities, including the right of exclusive possession and enjoyment, subject only to the terms and covenants of this Easement.

#### 5. ENFORCEMENT RIGHTS OF GRANTEE

A. To accomplish the purposes of this Easement the following rights are conveyed to Grantee by this Easement:

- (i) To preserve and protect the Transportation and Recreation Values of the Trail Easement Area;
- (ii) To prevent any activity on or use of the Trail Easement Area that is inconsistent with the purpose of this Easement and to require the restoration of such areas or features of the Trail Easement Area that may be damaged by any inconsistent activity or use, pursuant to subparagraphs B, C, and D of this Paragraph 5.

B. In the event that a violation of the terms of this Easement by Grantor or by a third party comes to the attention of Grantee, Grantee shall notify Grantor in writing of such violation and demand corrective action sufficient to cure the violation, and where the violation involves injury to the Trail Easement Area resulting from any use or activity inconsistent with the purposes of this Easement, to restore the portion of the Trail Easement Area so injured. If Grantor fails to cure the violation within thirty (30) days after receipt of such notice thereof from Grantee, or under circumstance where the violation cannot reasonably be assured within the thirty (30) day period, fails to begin curing such violation within the thirty (30) day period, or fails to continue diligently to cure such violation until finally cured, Grantee may bring an action at law or in equity in a court of competent jurisdiction to enforce the terms of this Easement, to enjoin the violation, *ex parte* as necessary, by temporary or permanent injunction, to recover any damages to which it may be entitled for violation of the terms of this Easement or injury to any Transportation and Recreation Values protected by the terms of this Easement, including damages for the loss of scenic, aesthetic, or environmental values, and to require the restoration of the Trail Easement Area to the condition that existing prior to any such injury. Without limiting Grantor's liability therefor, Grantee, in its sole discretion, may apply any damages recovered to the cost of undertaking any corrective action on the Trail Easement Area. If Grantee, in its sole discretion, determines that circumstance require immediate action to prevent or mitigate significant damage to the Recreation and Transportation Values of the Trail Easement Area, Grantee may pursue its remedies under this Paragraph 5 without prior notice to Grantor or without waiting for the period provided for cure to expire.

C. Grantee's rights under this Paragraph 5 apply equally in the event of either actual or threatened violations of the terms of this Easement, and Grantor agrees that Grantee's remedies at law for any violation of the terms of this easement are inadequate and that Grantee shall be entitled to the injunctive relief described in this Paragraph,

both prohibitive and mandatory, in addition to such other relief to which Grantee may be entitled, including specific performance of the terms of this Easement, without necessity of proving either actual damages or the inadequacy of otherwise available legal remedies.

D. Any costs incurred by Grantee in enforcing the terms of this Easement against Grantor, including, without limitation, costs of suit and attorneys' fees, and any costs or restoration necessitated by Grantor's violation of the terms of this Easement shall be borne by Grantor.

#### 6. MAINTENANCE AND ASSESSMENT OBLIGATIONS OF GRANTEE

*Note: Obligations may vary depending on whether the municipality holds the Trail Easement Area by easement or by ownership. If it holds the area by ownership or if it agrees through the easement to accept responsibilities, it is responsible for maintenance and assessment. In general, the municipality should be prepared to accept maintenance responsibilities except where the trail is on high traffic-generating properties such as commercial higher density residential or institutional properties for example municipally owned trails are generally not assessed taxes. Where trail easement areas remain in private ownership, the municipality should support waiver of assessment by county assessment offices.*

Grantee shall be [if trail is to be publicly owned and maintained] under no obligation to maintain the Trail Easement Area, or any portion thereof, or pay taxes or assessments thereon. Any action by Grantee such as maintenance of the Trail Easement Area or any other act by Grantor [Grantee-if privately held] to protect the Trail Easement Area shall be deemed merely a gratuitous act which shall create no obligation on the part of Grantor [Grantee].

#### 7. SUCCESSORS IN INTEREST

Except where the context requires otherwise, the term "Grantor" and "Grantee", as used in this instrument, and any pronouns used in place thereof, shall mean and include, respectively, Grantor and his personal representatives, heirs, successors in title, and assigns, and Grantee and its successors and assigns.

#### 8. STATEMENT OF COMPLIANCE

Grantor hereby agrees to request in writing at least thirty (30) days prior to the sale, transfer, or long term [ten (10) years or more] lease of the property containing the Trail Easement Area, or any portion thereof, a written instrument from Grantee stating that Grantor is in compliance with the terms and conditions of this Easement, or if Grantor is not in compliance with the terms and conditions of this Easement, stating what violations of this Easement exist. Grantee agrees in such cases or at any other time to acknowledge, execute, and deliver to Grantor or to any mortgagee, transferee, purchaser, or lessee such a written instrument concerning compliance within thirty (30) days of written request from Grantor. Grantor shall

provide a copy of Grantor's compliance statement to any purchaser, mortgagee, lessee, or assignee and shall advise Grantee in writing at least ten (10) days in advance of any transfer, long term lease, or sale of the Trail Easement Area, or any portion thereof. Any costs incurred by Grantee in determining compliance and advising Grantor as to compliance or costs incurred as a result of Grantor's failure to notify Grantee of transfer, sale, assignment, or long term lease of the Trail Easement Area, or any portion thereof, shall be paid by Grantor, [if the municipality does not agree to absorb such costs] his successors or assigns.

#### 9. LIMITATION OF GRANTOR LIABILITY

Grantor, and each subsequent owner of the Trail Easement Area, shall have no personal liability for the observance or performance of the covenants and obligations of Grantor hereunder after such party has conveyed his, her, its, or their interest in the Trail Easement Area, provided that the provisions of Paragraph 8, above, have been fulfilled and all obligations thereunder discharged.

#### 10. HOLD HARMLESS

Grantee, and each subsequent holder of the Trail Easement Area, shall hold harmless, indemnify, and defend Grantor and its heirs, personal representatives, successors, and assigns from and against all liability, penalties, costs, losses, damages, expenses, causes of action, claims, demands, or judgements, including, without limitation, reasonable attorneys' fees, arising from or in any way connected with: (1) injury to or the death of any person, or physical damage to any property, resulting from any act, omission, condition, or other matter related to or occurring on or about the Trail Easement Area, regardless of cause, unless due solely to the gross negligence or willful misconduct of the Grantor and its heirs, personal representatives, successors, and assigns; (2) the obligations specified in Paragraph 6, herein; and (3) the existence or administration of this Easement.

#### 11. STIPULATED VALUE OF GRANTEE'S INTEREST

A. Grantor acknowledges that this Easement constitutes a real property interest in the Trail Easement Area immediately vested in Grantee, and that such interest has a fair market value. For purposes of allocating net proceeds in an extinguishment of all or part of this Easement pursuant to Paragraph 12 herein, the share of Grantee's interest shall not be less than the percentage that the fair market value of this Easement on the date hereof bears to the fair market value of the Trail Easement Area prior to considering the effects of this Easement (hereinafter called the "Easement Percentage").

The values for calculating the Easement Percentage shall be based upon a Qualified Appraisal obtained by Grantor for federal income tax purposes. Upon receipt of such Qualified Appraisal, Grantor shall provide a copy of the Qualified Appraisal to Grantee. In the event that Grantor does not obtain a Qualified Appraisal, the Easement Percentage shall be thirty five (35) percent of

fair market value.

B. Grantor and Grantee, and any successors in interests, shall exhaust all legal remedies in order to preserve and protect the Transportation and Recreation Purposes of this Easement. Grantor shall cooperate with Grantee in Grantee's performance of its obligations under this Paragraph 11.

C. In the event that all or part of this Easement is taken in exercise of eminent domain by public, corporate, or other authority so as to abrogate the transportation and recreation goals imposed by this Easement, Grantor and Grantee shall join in appropriate action at the time of such taking to recover the full value of the taking and all incidental or direct damages resulting from the taking. All reasonable expenses incurred by Grantor and Grantee in an effort to prevent a taking or in an effort to recover the full value of a taking shall be shared on an equal basis out of any recovered proceeds except in the event that (i) Grantor and Grantee agree in writing to an alternative means for sharing such expenses, or (ii) all or part of this Easement is extinguished as a result of a judicial proceeding brought by or on behalf of Grantor which, in that event, then all expenses shall be paid by Grantor.

#### 12. EXTINGUISHMENT OF EASEMENT AND DISTRIBUTION OF NET PROCEEDS

A. In the event that all or part of the Trail Easement Area interests subject to this Easement are involuntarily extinguished by (i) an action in eminent domain, (ii) other judicial proceedings, or (iii) settlement is reached between Grantor, Grantee, and condemner under threat of condemnation, and Grantor joins with Grantee in accordance with Paragraph 11.B. and 11.C. above, Grantee's share of any proceeds recovered from any compensation in eminent domain or judicial proceedings or from the first lawful sale of the Trail Easement Area, after the restrictions within this Easement have been extinguished, shall equal the Easement Percentage, provided that a larger percentage has not been stipulated by agreement between Grantee and Grantor.

B. In the event that all or part of the Trail Easement Area interests subject to this Easement are extinguished by (i) an action in eminent domain, (ii) other judicial proceedings, or (iii) settlement is reached between Grantor, Grantee, and condemner under threat of condemnation, where such action is brought by or on behalf of Grantor or where Grantor does not join with Grantee in accordance with Paragraph 11.B. and 11.C. above, the value of the interests so taken shall be determined by an independent appraisal and the net proceeds recovered from any compensation in eminent domain or judicial proceedings or from the first lawful sale of the Trail Easement Area after the restrictions within this Easement have been extinguished, shall be distributed between Grantor and Grantee in accordance with the findings of an independent appraisal of the interests taken which has been conducted

by a Qualified Appraiser. Provided, however, that in no event shall Grantee's share of said net proceeds be less than the Easement Percentage.

C. Grantee shall use its share of any net proceeds recovered, as described in this Paragraph 12, exclusively for the protection or acquisition of interests in land or for Transportation and Recreation Purposes or for improvement to the trails system.

For purposes of this Paragraph, proceeds shall not include an amount equal to the fair market value of any Improvements by the Grantor to the Trail Easement Area affected by the condemnation or judicial action or any improvements to the Trail Easement Area by the Grantee, which were not included in the calculations by which the Easement Percentage was established.

13. FAILURE OF GRANTEE TO ENFORCE

If at any time any organization, agency, or person having rights or duties hereunder as Grantee shall fail to enforce the restrictions set forth in this Easement, Grantor, or any governmental unit of \_\_\_\_\_ County, shall have the right to bring suit against Grantee for specific performance.

14. TRANSFER OF GRANTEE'S INTEREST

A. Grantee, its successors and assigns, shall have the right to assign either wholly or partially its right, title, and interest hereunder only to an organization able to enforce the restrictions contained herein which has purposes similar to those of Grantee, and which encompasses the purposes set forth in this Easement. Such an organization must at the time of the assignment be a governmental unit qualified organization within the meaning of Section 170(h)(3) of the Internal Revenue Code of 1986 (or its successor provisions), hereinafter the "Code", and one which is organized or operated primarily or substantially for one of the conservation purposes specified in Section 170(h)(4)(A) of the Code. Any transfer or assignment of benefits by Grantee, its successors or assigns, must require the transferee or assignee to carry out the Transportation and Recreation Purposes of this Easement.

B. In the event Grantee shall cease to exist or to be a qualified organization as described in Subparagraph 14.A., herein, its rights and duties hereunder shall become vested in and fall upon one of the following named entities, or such other qualified organization as may then be determined, to the extent such entity shall evidence acceptance of and agree to fully enforce same:

- (i) \_\_\_\_\_ Land Trust;
- (ii) \_\_\_\_\_ Valley Association;
- (iii) The Nature Conservancy;
- (iv) \_\_\_\_\_ Watershed Association;
- (v) The Township(s) of \_\_\_\_\_, political subdivision(s) of \_\_\_\_\_ County and the Commonwealth of Pennsylvania;
- (vi) \_\_\_\_\_ County, a political subdivision of the Commonwealth of Pennsylvania; or

(vii) Such other organizations as may be designated under the doctrine of cy pres by a court of competent jurisdiction; provided, however, that at the time of such designation, such entity shall be an organization as described in Subparagraph 14.A. herein.

[Use the following paragraph only if funds were received by a private organization or a municipality as Grantee.]

C. Upon the occurrence of any transfer or assignment of this Easement, Grantee shall also transfer to the transferee or assignee the then-value of any endowment funds received by Grantee from Grantor to support Grantee's obligation to monitor and enforce of this Easement, and the transferee shall hold such funds for such purposes and be subject to the provisions of this subparagraph C.

15. EASEMENT IN PERPETUITY

The provisions hereof shall inure to and be binding upon the heirs, executors, administrators, devisees, successors, and assigns, as the case may be, of the parties hereto and shall be covenants running with the land in perpetuity.

16. SEVERABILITY

This Easement shall be construed in its entirety, however, in the event that any provision or restriction of this Easement or the application thereof to any person or circumstance is found to be invalid, the remainder of the provisions and restrictions of this Easement, and the application of such provision or restriction to persons or circumstances other than those as to which it is found to be invalid, shall not be affected thereby.

17. ACKNOWLEDGEMENTS

A. Grantor attests that Grantor is the owner of the Trail Easement Area and that the Trail Easement Area is not subject to a mortgage as of the date of this Easement. [Alternatively, a subordination agreement from the mortgagee for the Trail Easement Area must be obtained. Most mortgage companies will do so if the mortgage is for less than property value.]

IN WITNESS WHEREOF, and again stating their intention to be legally bound hereby, the said parties have hereunto set their hands and respective seals on the day and year first above written.

WITNESS \_\_\_\_\_

WITNESS \_\_\_\_\_

BY \_\_\_\_\_

(SEAL)

ATTEST \_\_\_\_\_

\_\_\_\_\_ )

\_\_\_\_\_ ) ss.

\_\_\_\_\_ )

BE IT REMEMBERED that on this day of \_\_\_\_\_, 199\_\_, personally appeared before me, the Subscriber, a Notary Public for the State and County aforesaid, \_\_\_\_\_, party to this Indenture, known to me personally to be such, and severally acknowledged this Indenture to be their deed.

GIVEN under my hand and seal of office, the day and year aforesaid.

Notary Public

\_\_\_\_\_)  
\_\_\_\_\_) ss.  
\_\_\_\_\_)

BE IT REMEMBERED that on this day of \_\_\_\_\_, 199\_\_, personally appeared before me, the Subscriber, a Notary Public for the State and County aforesaid, \_\_\_\_\_, President of Brandywine Conservancy, Inc., a corporation existing under the laws of the State of Delaware, party to this Agreement, and acknowledge this Indenture to be his act and deed and the act and deed of said corporation; that the signature of the President thereto is in his own proper handwriting and the seal affixed is the common and corporate seal of said corporation, and that his act of sealing, executing, acknowledging and delivering said Indenture was duly authorized by a resolution of the Board of Directors of said corporation.

GIVEN under my Hand and Seal of Office, the day and year aforesaid.

Notary Public



**Appendix IX.**  
**Trail Construction Costs**

## TRAIL CONSTRUCTION COSTS

Type of Work	Unit	Cost per Unit
Surveying/Staking	1,000 LF	\$15,000
Clearing/Stump Removal	acre	8,000
Grading (10' wide trail bed)	1,000 LF	10,000
Culvert (8" galvanized steel, 10' long)	each	300
Check Dam	each	200
Seeding (by hand)	acre	2,000
Wood Chip Tread (6' wide)	1,000 LF	1,300
Crushed Stone Tread (6' wide)	1,000 LF	7,500
2" thick asphalt tread (6' wide)	1000 LF	12,000
Large Sign (wood face and post)	each	200
Small Sign (wood face and post)	each	100
Bench (wood with iron frame)	each	400
Trash Can (fiberglass)	each	250

LF = linear feet

**Appendix X:  
Federal Highway  
Administration Funding  
for Bicycle and  
Pedestrian Projects**

# Federal Highway Administration

## Funding for Bicycle and Pedestrian Projects

Bicycle and pedestrian projects are broadly eligible for funding from most of the major Federal-aid highway, transit, safety, and other programs. Bicycle projects must be "principally for transportation, rather than recreation, purposes" and must be designed and located pursuant to the transportation plans required of States and Metropolitan Planning Organizations.

### FEDERAL-AID HIGHWAY PROGRAM

**National Highway System** funds may be used to construct bicycle transportation facilities and pedestrian walkways on land adjacent to any highway on the National Highway System including Interstate highways.

**Surface Transportation Program (STP)** funds may be used for either the construction of bicycle transportation facilities and pedestrian walkways, or nonconstruction projects (such as maps, brochures, and public service announcements) related to safe bicycle use and walking. TEA-21 adds "the modification of public sidewalks to comply with the Americans with Disabilities Act" as an activity that is specifically eligible for these funds.

Ten percent of each State's annual STP funds are set aside for **Transportation Enhancement Activities (TEAs)**. The law provides a specific list of activities that are eligible TEAs and this list includes "provision of facilities for pedestrians and bicycles, provision of safety and educational activities for pedestrians and bicyclists," and the "preservation of abandoned railway corridors (including the conversion and use thereof for pedestrian and bicycle trails)."

Another 10 percent of each State's STP funds is set aside for the **Hazard Elimination and Railway-Highway Crossing programs**, which address bicycle and pedestrian safety issues. Each State is required to implement a Hazard Elimination Program to identify and correct locations that may constitute a danger to motorists, bicyclists, and pedestrians. Funds may be used for activities including 1) a survey of hazardous locations and 2) projects on any publicly owned bicycle or pedestrian pathway or trail, or 3) any safety-related traffic calming measure. Improvements to railway-highway crossings "shall take into account bicycle safety."

**Congestion Mitigation and Air Quality Improvement Program** funds may be used for either the construction of bicycle transportation facilities and pedestrian walkways, or nonconstruction projects (such as maps, brochures, and public service announcements) related to safe bicycle use.

**Recreational Trails Program** funds may be used for all kinds of trail projects. Of the funds apportioned to a State, 30 percent must be used for motorized trail uses, 30

percent for nonmotorized trail uses, and 40 percent for diverse trail uses (any combination).

Provision for pedestrians and bicyclists are eligible under the various categories of the **Federal Lands Highway Program** in conjunction with roads, highways, and parkways. Priority for funding projects is determined by the appropriate Federal Land Agency or Tribal government.

**National Scenic Byways Program** funds may be used for construction of a facility along a scenic byway for pedestrians and bicyclists.

**Job Access and Reverse Commute Grants** are available to support projects, including bicycle-related services, designed to transport welfare recipients and eligible low-income individuals to and from employment.

**High Priority Projects and Designated Transportation Enhancement Activities** identified by TEA-21 include numerous bicycle, pedestrian, trail, and traffic calming projects in communities throughout the country.

## FEDERAL TRANSIT PROGRAM

Title 49 U.S.C. (as amended by TEA-21) allows the **Urbanized Area Formula Grants, Capital Investment Grants and Loans, and Formula Program for Other than Urbanized Area** transit funds to be used for improving bicycle and pedestrian access to transit facilities and vehicles. Eligible activities include investments in "pedestrian and bicycle access to a mass transportation facility" that establishes or enhances coordination between mass transportation and other transportation.

TEA-21 also created a **Transit Enhancement Activity** program with at 1 percent set-aside of Urbanized Area Formula Grant funds designated for, among other things, pedestrian access and walkways, and "bicycle access, including bicycle storage facilities and installation equipment for transporting bicycles on mass transportation vehicles."

## HIGHWAY SAFETY PROGRAMS

Pedestrian and bicyclist safety remain priority areas for **State and Community Highway Safety Grants** funded by the Section 402 formula grant program. A State is eligible for these grants by submitting a Performance plan (establishing goals and performance measures for improving highway safety) and a Highway Safety Plan (describing activities to achieve those goals.)

Research, development, demonstrations, and training to improve highway safety (including bicycle and pedestrian safety) is carried out under the Highway Safety Research and Development (Section 403) program.

## **FEDERAL/STATE MATCHING REQUIREMENTS**

In general, the Federal share of the costs of transportation projects is 80 percent with a 20 percent State or local match. However, there are a number of exceptions to this rule.

- Federal Lands Highway projects and Section 402 Highway Safety funds are 100 percent federally funded.
- Bicycle-related Transit Enhancement Activities are 95 percent federally funded.
- Hazard elimination projects are 90 percent federally funded. Bicycle-related transit projects (other than Transit Enhancement Activities) may be up to 90 percent federally funded.
- Individual Transportation Enhancement Activity projects under the STP can have a Federal match higher or lower than 80 percent. However, the overall Federal share of each State's Transportation Enhancement Program must be 80 percent.
- States with higher percentages of Federal Lands have higher Federal shares calculated in proportion to their percentage of Federal lands.
- The State and/or local funds used to match Federal-aid highway projects may include in-kind contributions (such as donations). Funds from other Federal programs may also be used to match Transportation Enhancement, Scenic Byways, and Recreational Trails program funds. A Federal agency project sponsor may provide matching funds to Recreational Trails funds provided the Federal share does not exceed 95 percent.

**Appendix XI:  
Code of Virginia  
Section 29.1-509  
The Liability Law**



**Duty of care and liability for damages of landowners to hunters, fishermen, sightseers, etc.**

A. For the purpose of this section:

"Fee" means any payment or payments of money to a landowner for use of the premises or in order to engage in any activity described in subsections B and C of this section, but does not include rentals or similar fees received by a landowner from governmental sources or payments received by a landowner from incidental sales of forest products to an individual for his personal use, or any action taken by another to improve the land or access to the land for the purposes set forth in subsections B and C of this section or remedying damage caused by such uses.

"Land" or "premises" means real property, whether rural or urban, waters, boats, private ways, natural growth, trees and any building or structure which might be located on such real property, waters, boats, private ways and natural growth.

"Landowner" means the legal title holder, lessee, occupant or any other person in control of land or premises.

B. A landowner shall owe no duty of care to keep land or premises safe for entry or use by others for hunting, fishing, trapping, camping, participation in water sports, boating, hiking, rock climbing, sightseeing, hang gliding, skydiving, horseback riding, foxhunting, racing, bicycle riding or collecting, gathering, cutting or removing firewood, for any other recreational use, or for use of an easement granted to the Commonwealth or any agency thereof to permit public passage across such land for access to a public park, historic site, or other public recreational area. No landowner shall be required to give any warning of hazardous conditions or uses of, structures on, or activities on such land or premises to any person entering on the land or premises for such purposes, except as provided in subsection D.

C. Any landowner who gives permission, express or implied, to another person to hunt, fish, launch and retrieve boats, swim, ride, foxhunt, trap, camp, hike, rock climb, hang glide, skydive, sightsee, engage in races, to collect, gather, cut or remove forest products upon land or premises for the personal use of such person, or for the use of an easement as set forth in subsection B does not thereby:

1. Impliedly or expressly represent that the premises are safe for such purposes; or
2. Constitute the person to whom such permission has been granted an invitee to whom a duty of care is owed; or
3. Assume responsibility for or incur liability for any intentional or negligent acts of such person or any other person, except as provided in subsection D.

D. Nothing contained in this section, except as provided in subsection E, shall limit the liability of a landowner which may otherwise arise or exist by reason of his gross negligence or willful or malicious failure to guard or warn against a dangerous condition, use, structure, or activity. The provisions of this section shall not limit the liability of a landowner which may otherwise arise or exist when the landowner receives a fee for use of the premises or to engage in any activity described in subsections B and C of this section. Nothing contained in this section shall relieve any



sponsor or operator of any sporting event or competition including but not limited to a race or triathlon of the duty to exercise ordinary care in such events.

E. For purposes of this section, whenever any person enters into an agreement with, or grants an easement to, the Commonwealth or any agency thereof, any county, city, or town, or with any local or regional authority created by law for public park, historic site or recreational purposes, concerning the use of, or access over, his land by the public for any of the purposes enumerated in subsections B and C of this section, the government, agency, county, city, town, or authority with which the agreement is made shall hold a person harmless from all liability and be responsible for providing, or for paying the cost of, all reasonable legal services required by any person entitled to the benefit of this section as the result of a claim or suit attempting to impose liability. Any action against the Commonwealth, or any agency, thereof, for negligence arising out of a use of land covered by this section shall be subject to the provisions of the Virginia Tort Claims Act (§8.01-195.1 et seq.). Any provisions in a lease or other agreement which purports to waive the benefits of this section shall be invalid, and any action against any county, city, town, or local or regional authority shall be subject to the provisions of §15.2-1809, where applicable.

# **Appendix XII: Equine Documents**

Be it enacted by the General Assembly of Virginia:

1. That the Code of Virginia is amended by adding in Title 3.1 a chapter numbered 27.5, consisting of sections numbered 3.1-796.130 through 3.1-796.133 as follows:

## CHAPTER 27.5. EQUINE ACTIVITY LIABILITY ACT

§ 3.1-796.130. Definitions. - As used in this chapter, unless the context requires a different meaning:

"Directly engages in an equine activity" means a person who rides, trains, drives, or is a passenger upon an equine, whether mounted or unmounted, but does not mean a spectator at an equine activity or a person who participates in the equine activity but does not ride, train, drive, or ride as a passenger upon an equine.

"Equine" means a horse, pony, mule, donkey, or hinny

"Equine activity" means (i) equine shows, fairs, competitions, performances, or parades that involve any or all breeds of equines and any of the equine disciplines, including, but not limited to, dressage, hunter and jumper horse shows, grand prix jumping, three-day events, combined training, rodeos, driving, pulling, cutting, polo, steeple chasing, endurance trail riding, and western games, and hunting; (ii) equine training or teaching activities; (iii) boarding equines; (iv) riding, inspecting, or evaluating an equine belonging to another whether or not the owner has received some monetary consideration or other thing of value for the use of the equine or is permitting a prospective purchaser of the equine to ride, inspect, or evaluate the equine; and (v) rides, trips, hunts, or other equine activities of any type however informal or impromptu that are sponsored by an equine activity sponsor.

"Equine activity sponsor" means any person or his agent who, for profit or not for profit sponsors, organizes, or provides the facilities for an equine activity, including but not limited to pony clubs, 4-H clubs, hunt clubs, riding clubs, school- and college-sponsored classes and programs, therapeutic riding programs, and operators, instructors, and promoters of equine facilities, including but not limited to stables, clubhouses, ponyride strings, fairs, and arenas at which the activity is held.

"Equine professional" means a person or his agent engaged for compensation in (i) instructing a participant or renting to a participant an equine for the purpose of riding, driving, or being a passenger upon an equine of (ii) renting equipment or tack to a participant.

"Participant" means any person, whether amateur or professional, who directly engages in an equine activity, whether or not a fee is paid to participate in the equine activity.

§ 3.1-796.131. Horse racing excluded. - The provisions of this chapter shall not apply to horse racing, as that term is defined by § 59.1-365.

§ 3.1-796.132. Liability limited; liability actions prohibited. - A. Except as provided in § 3.1-796.133, an equine activity sponsor or an equine professional shall not be liable for an injury to or death of a participant engaged in an equine activity.

B. Except as provided in § 3.1-796.133, no participant or parent or guardian of a participant who has knowingly executed a waiver of his rights to sue or agrees to assume all risks specifically enumerated under this subsection may maintain an action against or recover from an equine activity sponsor or an equine professional for an injury to or the death of a participant engaged in an equine activity. The waiver shall give notice to the participant of the risks inherent in equine activities, including (i) the propensity of an equine to behave in dangerous ways which may result in injury to the participant; (ii) the inability to predict an equine's reaction to sound, movements, objects, persons, or animals; and (iii) hazards of surface or subsurface conditions. The waiver shall remain valid unless expressly revoked by the participant or parent or guardian of a minor. In the case of school and college sponsored classes and programs, waivers executed by a participant or parent or guardian of a participant shall apply to all equine activities in which the participant is involved in the next succeeding twelve month period unless earlier expressly revoked in writing.

§ 3.1-796.133. Liability of equine activity sponsors, equine professionals. - No provision of this chapter shall prevent or limit the liability of an equine activity sponsor or equine professional who:

1. Intentionally injures the participant
2. Commits an act or omission that constitutes negligence for the safety of the participant and such act or omission caused the injury, unless such participant, parent, or guardian has expressly assumed the risk causing the injury in accordance with § 3.1-796.132 B; or
3. Knowingly provides faulty equipment or tack and such equipment or tack causes the injury or death of the participant.

**Equine Activity Release, Waiver or Right of Sue  
And Assumption of All Risks**

The Equine Liability Release, Waiver of Right to Sue and Assumption of All Risks Agreement ("this Agreement") is hereby given by the undersigned to the \_\_\_\_\_, an equine activity sponsor and to the sponsor as agent for and for the benefit of each owner of land upon which an equine activity to which this Agreement relates is conducted ("owner") and each partner, officer, agent, employee, director, shareholder, member, heir, personal representative, successor and assign of the sponsor and of each owner (who shall be included within the words "sponsor" or "owner" as their relationships may determine) provides as follows:

In consideration for the opportunities provided by the sponsor and each owner to the undersigned "participant" (including any minor participant for whom he signs this Agreement) for the enjoyment of equine activities as a participant, the undersigned "participant" (including any minor participant for whom he signs this agreement) hereby agrees as follows:

1. This Agreement is given under the Virginia Equine Activity Liability Act (Code of Virginia § 3.1-796.130 et seq) and the Duty of Care and Liability for Damages of Landowners to Hunters, Fisherman, Sightseers, ect (§ 29.1.509), as they may now provide or be hereafter amended (the "Acts"). All terms defined by the Acts shall have the same meaning herein, and the Acts are hereby incorporated in this Agreement by reference. This Agreement shall be so construed as to provide to the sponsor and owner the fullest protection of a release, waiver of right to sue and assumption of all risks which is afforded to the sponsor and owners by the Acts.
2. All pronouns shall be construed to include the masculine, feminine or neuter as well as the plural or singular, as may be appropriate to facilitate the construction of this Agreement in the light of the facts presented.
3. The participant hereby acknowledges that he has full and complete notice and understanding of the Acts and of all the risks inherent in equine activities which may cause, contribute to or result in the death or personal injury of the participant or damage to the participant's property (the "Risks"), including but not limited to:
  - (i) the propensity of an equine to behave in dangerous ways or to trip and/or fall;
  - (ii) the inability of anyone whomsoever to predict or foresee an equine's reaction to excitement, weather conditions, sound, movements, objects, persons, animals, reptiles, birds or insects, and the effects of such reactions;  
  
the hazards of surface or subsurface conditions, including but not limited to objects or conditions on, under or protruding from the surface, both latent and patent;  
  
the hazards which rocks, cliffs, hills, fences, trees, stumps, logs, bridges, ditches and other debris and obstacles, and any equine activity in connection therewith, may foreseeably or unforeseeably present;
  - (v) the dangers and risks of becoming entangled in tack, harness, or vehicles used in an equine activity for any reason whatsoever or for no identifiable reason and  
  
any negligent act or omission by the sponsor or any owner which causes or results in the death or personal injury of the participant or damage to the participant's property.
4. The participant hereby **RELEASES and WAIVES** all rights which he may have or hereafter have against the sponsor and each owner for death, personal injury or property damage which is in any way associated with the Risks; he does hereby **WAIVE** his right to sue or to bring any action against the sponsor and each owner from and to **HOLD** the sponsor and each owner **HARMLESS** against any such suit or action; and he hereby expressly **ASSUMES ALL RISKS AND DANGERS** of death, personal injury and property damage which are in any way associated with the Risks enumerated in paragraph 3, above.

5. The participant hereby authorizes and consents to any emergency medical care, which may at the time, appear reasonably appropriate under the circumstances as a result of injury or sickness caused by or incurred in the course of an equine activity.
6. I agree to abide by all of the rules of the \_\_\_\_\_. I understand that distance riding involves being in remote areas for extended periods of time, far from communications, transportation, and medical facilities; that these areas have many natural and man made hazards, which facility management cannot anticipate, identify, modify, or eliminate. I agree to take full responsibility for myself and the animal I am riding.
7. This Agreement shall remain valid and in full force and effect from and after the date opposite the signature of the participant until expressly revoked by the participant in a written notice personally delivered to the sponsor.
8. To the extent possible, this Agreement shall be construed in such manner as will render it, and each provision of it, fully enforceable; but if any provision of this Agreement shall be unenforceable, such provision (or so much thereof as is unenforceable) shall be deleted and the remainder of this agreement shall continue in full force and effect.
9. If this Agreement is executed by the undersigned participant for and on behalf of a minor participant named below, the undersigned participant hereby warrants and represents that he is in fact the legal parent or guardian of such minor, with full rights of custody and control; that this Agreement is given on behalf of and is intended to be binding upon said minor participant, his heirs, personal representatives, successors and assigns; and the undersigned participant as if it were entered into solely on his own behalf.
10. This Agreement shall be binding upon the heirs, personal representatives, successors and assigns of the participant.
11. I have fully read and fully understand the foregoing Equine Liability Release, Waiver of Right to Sue and Assumption of All Risks. I have consulted and relied upon my own advisors on all questions in connection therewith, and I have not relied upon the sponsor or any owner for advice or explanation in connection therewith.

Print Name: \_\_\_\_\_ Date: \_\_\_\_\_  
Participant

Signature: \_\_\_\_\_

Print name of the minor participant for whom you are signing, if any.

\_\_\_\_\_

# **RULES AND REGULATIONS**

**2 VAC 5-70-10 through 2 VAC 5-70-50**  
(Previously VR 115-02-05)

Pertaining to the

## **HEALTH REQUIREMENTS GOVERNING THE CONTROL OF EQUINE INFECTIOUS ANEMIA IN VIRGINIA**

Virginia Department of Agriculture  
and Consumer Services



**DIVISION OF ANIMAL INDUSTRY SERVICES**

Office of Veterinary Services

P. O. Box 1163

Richmond, VA 23218

804-786-2483

**RULES AND REGULATIONS**  
**Pertaining to the**  
**Health Requirements Governing the Control of**  
**Equine Infectious Anemia in Virginia**  
(Previously VR 115-02-05)

Promulgated Pursuant to  
Sections 3.1-724 through 3.1-730  
of the  
Code of Virginia of 1950

Adopted November 27, 1985  
Reprinted June 1998





Pertaining to the  
HEALTH REQUIREMENTS GOVERNING THE CONTROL  
OF EQUINE INFECTIOUS ANEMIA IN VIRGINIA

Pursuant to the authority in Sections 3.1-724 through 3.1-730 of the Code of Virginia (1950) as amended, the Board of Agriculture and Consumer Services hereby adopts the following Rules and Regulations relating to the Health Requirements Governing the Control of Equine Infectious Anemia in Virginia.

2 VAC 5-70-10. Definitions.

The following words and terms, when used in these regulations, shall have the following meaning, unless the context clearly indicates otherwise:

*"Accredited veterinarian"* means a licensed veterinarian approved by the United States Department of Agriculture/Animal and Plant Health Inspection Service (hereinafter referred to as USDA-APHIS) and State Veterinarian.

*"Approved laboratory"* means a laboratory approved by USDA-APHIS or the State Veterinarian to conduct the official test for equine infectious anemia.

*"Approved veterinarian"* means a state-federal regulatory veterinarian, an accredited veterinarian, or other veterinarian approved by the State Veterinarian for special testing.

*"Department"* means the Virginia Department of Agriculture and Consumer Services.

*"Equine Infectious Anemia"* (EIA or Swamp Fever) means a contagious and infectious disease of horses, characterized by a variety of symptoms related to anemia. It may be acute, subacute, or chronic in nature and may terminate in death. The virus remains in the blood of infected animals throughout their lifetime. The virus may be spread from horse to horse via biting flies, mosquitoes, hypodermic needles, or blood-letting procedures.

*"Horse"* includes all horselike animals embracing all members of the equine species including horses, ponies, the asinine species, and burros. It also includes hybrid offspring of the equine and asinine species by whatever name they may be known, such as mules, hinnies, and donkeys.

*"Interstate health certificate"* means a legible record covering the health requirements for importing horses into Virginia, executed on an approved form of the state of origin, and bearing the endorsement of the livestock health official of that state.

*"Licensed veterinarian"* means a veterinarian who has graduated from a recognized college of veterinary medicine and has been examined and found proficient by the Virginia State Board of Veterinary Medicine.

*"Official test"* means the agar gel immunodiffusion test (Coggins AGID).

*"Reactor"* means a horse over eight (8) months of age that reacts positively to an official test performed by an approved laboratory.

"State-Federal Regulatory Veterinarian" means a veterinarian employed by the State Veterinarian or USDA-APHIS.

"State Veterinarian" means a Virginia Department of Agriculture and Consumer Services veterinarian employed by the Commissioner of Agriculture and Consumer Services who is responsible for the animal health programs in the Commonwealth of Virginia.

"Veterinary services" means services of USDA, APHIS.

**2 VAC 5-70-20. Testing requirements for horses exhibited at shows, fairs, or other exhibitions in Virginia.**

All horses assembled at a show, fair, race, meet, or other such function in Virginia, must be accompanied by a report of an official negative test for equine infectious anemia conducted within 12 months prior to such event. The person in charge will ensure that a copy of the official negative test results accompanies each horse in the event and shall make such reports available for inspection by a representative of the State Veterinarian upon request. The person in charge shall exclude any horse which is not accompanied by a negative test report.

**2 VAC 5-70-30. Alternate testing requirements for horses assembled for sale or auction in Virginia.**

Horses may be assembled at a sale or auction without a negative test for equine infectious anemia, provided that the State Veterinarian so approves, and that the following requirements are met:

- A. All horses, while assembled at the sale or auction, shall have blood samples drawn for equine infectious anemia testing.
- B. Horses consigned or sold for immediate slaughter to an official slaughtering establishment are exempt from equine infectious anemia testing. Such horses shall be identified in a manner approved by the State Veterinarian, and a written permit shall be issued for their transfer to the slaughtering establishment.
- C. The owner or manager of the sale or auction shall employ a licensed accredited veterinarian, who shall draw blood samples from all horses required to be tested, and shall record all visible markings or other permanent identification for each horse bled.
- D. The owner or manager shall announce, prior to the sale or auction, that all non-slaughter horses will be tested. Each buyer of a non-slaughter horse or horses at the sale or auction shall sign a release form, signifying his agreement to maintain such horse or horses at a specified location until notified of the results of the test. Horses that prove negative to the test may move in normal trade channels. Owners of horses that react to the test must comply with section 2 VAC 5-70-40 of this regulation.
- E. The State Veterinarian may grant such exceptions to these requirements as he feels the circumstances warrant and that are not in variance with other rules and regulations of the Commonwealth of Virginia.

**2 VAC 5-70-40.****Reactors to the official test.**

- A. Horses which have reacted positive to the official test shall be quarantined to the premises where tested by a State-Federal Regional Veterinarian.
- B. When a reactor is disclosed on a premises, and such testing does not constitute a complete herd test, then all horses on such premises shall be tested, including the test-positive animal. The required testing will be for the purpose of detecting additional infection and to confirm the identity of the reactors. Such testing will be performed under the supervision of a representative of the State Veterinarian. Additional testing may be required by the State Veterinarian to clarify the equine infectious anemia status of horses on the premises.
- C. Reactor animals shall be permanently identified by a freeze brand, using the official Commonwealth of Virginia code identification (52A) placed under the mane. The branding of such reactors will be performed by or under the supervision of a representative of the State Veterinarian.
- D. Negative horses on the premises where a reactor animal is disclosed may not be removed from such premises without the approval of the State Veterinarian.
- E. Virginia horses under eight (8) months of age which have reacted to the official test shall be placed under written quarantine and retested when they become eight (8) months of age. If such animals are reactors when they are eight (8) months of age, they shall be subject to the same regulation as the adult infected animal.
- F. When a reactor is disclosed, a thorough investigation shall be made to determine the source of disease and to determine whether spread has occurred. Depending upon these findings, additional testing may be required by the State Veterinarian.

**2 VAC 5-70-50.****Disposition of reactor animals.**

- A. Reactor horses may be humanely destroyed. The destruction of such horses shall be the owner's responsibility and at his or her expense, but will be done under the supervision of a representative of the State Veterinarian.
- B. Reactor horses may be further identified as required by the State Veterinarian and sold:
  - 1. Under permit to an approved slaughter establishment,
  - 2. To a market for sale to an approved slaughter establishment, or
  - 3. For rendering or research purposes.
- C. At owner's option, reactor horses may be retained under quarantine and held in isolation from all other horses on the premises. Provisions may be made under terms specified by the State veterinarian for the use of such reactor animals by the owner or his agent in such a manner that there is no risk of spreading equine infectious anemia. The terms and conditions shall be made part of the quarantine document. The restrictions placed on the movement and maintenance of reactor animals shall be permanent or until such animals die, are destroyed, or are cleansed of the carrier state.
- D. When reactor animals are quarantined as provided herein, all other horses on the premises may be required to be tested every six (6) months if deemed necessary by the State Veterinarian.

E. Whenever it has been determined that the provisions of the quarantine and isolation are not being maintained, the State Veterinarian may require that all horses on the premises be placed under quarantine. This quarantine shall remain in effect until the State Veterinarian has determined that the threat to the health of other horses no longer exists.



in addition  
to the  
provisions



in addition  
to the  
provisions

in addition  
to the  
provisions





Virginia Department of Agriculture  
and Consumer Services  
Office of Veterinary Services  
P. O. Box 1163  
Richmond, VA 23218  
804-786-2483

Send original form to appropriate Regional Office

# EQUINE EVENT REPORT

(Equidae with Official EIA Test)

Date of Event: \_\_\_\_\_

Name of Event: \_\_\_\_\_

Location of Event: \_\_\_\_\_

I hereby certify that all equidae (horses, mules, etc.) assembled for this event were accompanied by a report of an official negative test for equine infectious anemia conducted within 12 months prior to the event.

Signature - Sale/Show Chairman/Manager \_\_\_\_\_

Address (City, State, Zip) \_\_\_\_\_

## LIST OF EXHIBITING EQUIDAE

No.	Name of Owner	Owner's Address	Equidae Name	Test Date	State	Lab Access. No.
1						
2						
3						
4						
5						
6						
7						
8						
9						
10						
11						
12						
13						
14						
15						

No.	Name of Owner	Owner's Address	Equidae Name	Test Date	State	Lab Access. No.
16						
17						
18						
19						
20						
21						
22						
23						
24						
25						
26						
27						
28						
29						
30						
31						
32						
33						
34						
35						
36						
37						
38						
39						
40						

6





Virginia Department of Agriculture  
and Consumer Services  
Office of Veterinary Services  
P. O. Box 1163  
Richmond, VA 23218  
804-786-2483  
Send original form to appropriate Regional Office

# EQUINE EVENT REPORT

(Equidae [Horses, Mules, etc.] Denied Entry)

Name of Event: \_\_\_\_\_

Date of Event: \_\_\_\_\_

Location of Event: \_\_\_\_\_

I hereby certify that the below listed equidae were denied entry into this event because of improper, falsified, or no report of an official negative test for equine infectious anemia.

Signature - Sale/Show Chairman/Manager \_\_\_\_\_

Address (City, State, Zip) \_\_\_\_\_

### EQUIDAE DENIED ENTRY

No.	Name of Owner	Address	Equidae Name	Reason
1				
2				
3				
4				
5				
6				
7				
8				
9				
10				
11				
12				
13				
14				
15				



J. Carlton Courter, III  
Commissioner

# COMMONWEALTH of VIRGINIA

Department of Agriculture and Consumer Services  
Division of Animal Industry Services

*Office of Veterinary Services*

PO Box 1163, Richmond, Virginia 23218

Phone: 804/786-2483 • Fax: 804/371-2380 • Hearing Impaired: 800/828-1120  
<http://www.state.va.us/~vdacs/vdacs.htm>

September 29, 1998

Mr. Scott Shanklin  
Bear Creek State Park  
Rt. 1, Box 253  
Cumberland, VA 23040

Dear Mr. Shanklin:

For your information and use, I am enclosing copies of Virginia Regulation VR 115-02-05, Rules and Regulations Pertaining to the Health Requirements Governing the Control of Equine Infectious Anemia (EIA) in Virginia. Note that section 2 of this regulation indicates the responsibilities of management involved in shows, fairs, races, meets, and other such functions as to a required official negative test report for EIA to accompany each horse assembled for the event.

To assist equine event managers in keeping the required report of entries and evidence of a negative EIA test, I have enclosed forms which may be used for this purpose. The report can be easily made at the same time each animal is checked into the event. After the event, the original should be sent to this office, with the event management retaining a copy (xerox or carbon) for their files.

Please note that one of the enclosed forms is for reporting all equines with negative results; i.e., Equine Event Report (Equidae with Official EIA Test), as well as a Continuation Sheet. The other form is to report all horses denied entry because of improper or no official negative test for EIA; i.e., Equine Event Report (Equidae [horses, mules, etc.] Denied Entry). In addition, a sample copy of the official EIA test record is enclosed, with pertinent blocks on the form circled to indicate where the information needed to fill out the Equine Event Report can be found.

Please feel free to make as many copies of the Equine Event Report forms as you need. We appreciate your assistance in protecting Virginia's equine industry, and if you have any questions, please contact us [telephone: (804) 786-2483].

Sincerely,

R. D. Whiting, D.V.M.  
Program Coordinator  
Veterinary Services

Enclosures:



U.S. DEPARTMENT OF AGRICULTURE  
ANIMAL AND PLANT HEALTH INSPECTION SERVICE  
**EQUINE INFECTIOUS ANEMIA LABORATORY TEST**  
(VS Minimumum 555.8)

1. ACCESSION NUMBER \_\_\_\_\_ 2. DATE \_\_\_\_\_

3. NAME AND ADDRESS OF OWNER (Street, City, State and Zip Code)  
\_\_\_\_\_  
Tel. No. - AC ( ) \_\_\_\_\_

4. NAME AND ADDRESS WHERE HORSE IS STABLED (Street, City, State and Zip Code)  
\_\_\_\_\_  
Tel. No. - AC ( ) \_\_\_\_\_

5. NAME AND ADDRESS OF VETERINARIAN (Street, City, State and Zip Code. Print name and address legibly for window envelope use)  
\_\_\_\_\_  
Tel. No. - AC ( ) \_\_\_\_\_

6. MARKET TEST  YES  NO  
7. NAME AND ADDRESS OF AUCTION MARKET (Street, City, State and Zip Code)  
\_\_\_\_\_  
Tel. No. - AC ( ) \_\_\_\_\_

*SAMPLE*

8. FEDERALLY ACCREDITED VET.  
 YES  NO  
9. STATE IN WHICH LICENSED \_\_\_\_\_

I hereby certify that the blood specimen submitted with this form was drawn by me from the horse described below on the date indicated.  
10. SIGNATURE OF VETERINARIAN \_\_\_\_\_  
11. TELEPHONE NO. \_\_\_\_\_  
12. DATE SAMPLE DRAWN \_\_\_\_\_  
AC ( ) \_\_\_\_\_

13. IDENTIFICATION DATA

TUBE NO.	OFFICIAL TAG NO.	TATTOO/BRAND NO.	NAME OF HORSE	COLOR	REG. NO.	BREED	AGE	SEX

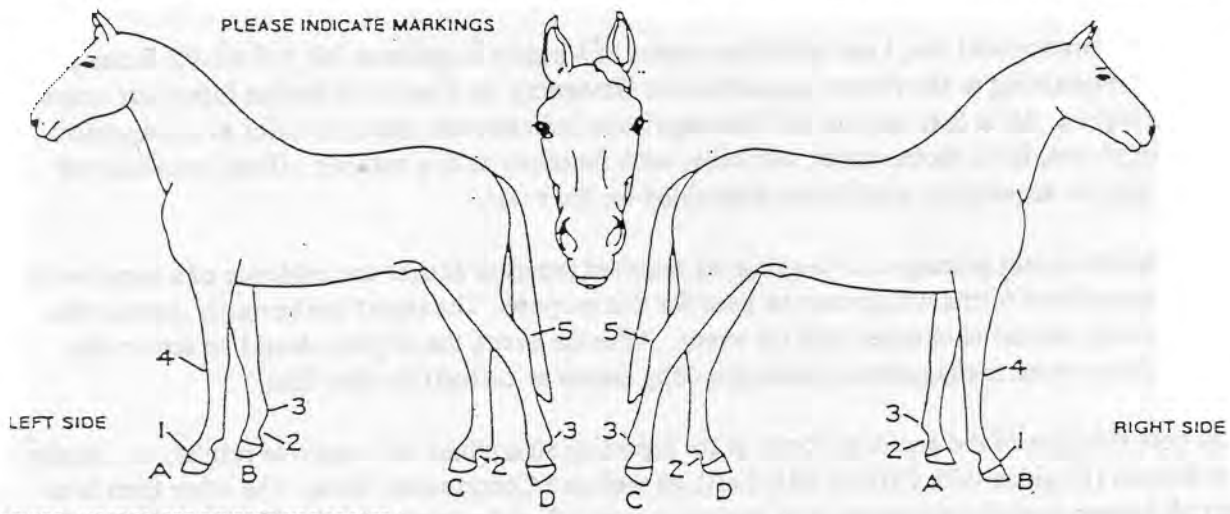

FOR DESCRIPTION GUIDE - HORSES, SEE REVERSE SIDE OF PART 1

14. REASON FOR TESTING (If other than Equine Infectious Anemia)  
\_\_\_\_\_  
15. DESCRIPTION AND REMARKS (Left Side)  
\_\_\_\_\_  
16. DESCRIPTION AND REMARKS (Right Side)  
\_\_\_\_\_

A - LEFT OR NEAR FORE LEG  
 B - RIGHT OR OFF FORE LEG  
 C - RIGHT OR OFF HIND LEG  
 D - LEFT OR NEAR HIND LEG  
 1 - Coronet      M - Mare  
 2 - Pastern      S - Stallion  
 3 - Fetlock      G - Gelding  
 4 - Knee          N - Neuter  
 5 - Hock

FOR LABORATORY USE ONLY

17. DATE RECEIVED _____	18. DATE REPORTED _____	19. TEST RESULT _____	20. REMARKS _____ R. D. Whiting, D.V.M. Program Coordinator Veterinary Services
21. NAME OF LABORATORY _____	22. SIGNATURE _____		

**Appendix XIII:  
Managing Multiple Use  
Trail Conflict**

## *Multiple Use Trail Management: Challenges faced by multiple use trail managers*

The challenges of multiple use trails focus on user safety, protecting natural resources, and providing high-quality user experiences. Managers can meet the potential challenges through good trail design, information and education efforts and programs, user involvement and regulations and enforcement.

### a. Maintain user Safety

#### **Threats to user safety**

- collisions and near misses among users and/or vehicles
- reckless and irresponsible behavior
- poor user preparation and judgement
- unsafe conditions related to trail use
- unsafe conditions not related to trail use
- poor trail design, construction, maintenance or management
- other hazards

#### **Factors to control to improve user safety**

- user speed, or speed differential
- mass of user and vehicle
- sight distances
- trail width
- trail surface
- congestion
- users overtaking one other without warning
- trail difficulty
- user skill level and experience
- user expectation and preparedness
- emergency procedures
- on-site management presence

### b. Protecting Natural Resources

Minimizing environmental impacts is a high priority. Negative resource impacts not only are undesirable because of Virginia State Park's mission, but also affect user satisfaction.

#### **Factors that influence the amount of resource damage caused by trail use:**

- Soil characteristics
- slope
- exposures

- elevation
- type of ecosystem
- type of wildlife
- type of vegetation **in trail**
- type of vegetation and terrain beside trail
- quality of trail design and construction
- level of maintenance
- type of use
- concentration or dispersal of use
- season of use
- difficulty of terrain
- up or down hill traffic direction
- style of use or technique

c. Providing High quality experience

**Threats to quality experience**

- crowding
- conflict--activity styles, resource specificity, mode of experience, tolerance for lifestyle diversity

*Moore, Roger L. (1994). Conflicts on Multiple-Use Trails: Synthesis of the Literature and the State of the Practice. Federal Highway Administration, Intermodal Division, FHWA-PD-94-031.*

Factors that

**Appendix XIV·  
Trail Log &  
Inspection Form**

## Virginia State Parks Trail Log and Inspection

Trail Name: \_\_\_\_\_  
 Type of Usage: \_\_\_\_\_  
 Length: \_\_\_\_\_  
 Trail Width: \_\_\_\_\_  
 Trail Grade: \_\_\_\_\_  
 Surfacing/Tread Material: \_\_\_\_\_  
 Difficulty Rating: \_\_\_\_\_  
 Design Capacity (circle one):    Heavy    Moderate    Low  
 Log Completed By: \_\_\_\_\_ Date: \_\_\_\_\_

### General Conditions/Assessment

Inspection Date

	Good	Fair	Poor	Notes
Tread/Surface				
Surface Erosion				
Surface Drainage				
Trail Corridor--Vertical & Horizontal				
Usage Limit	(Below)	(Normal)	(Above)	
Blaze Condition				
Sign Condition				

### Routine Maintenance

Inspection Date

	Needed	Not Needed	Done At Inspection	Date Work Completed	Notes
Dead Wood, Brush, Tree Removal					
Pruning, trimming, grooming					
Trash Removal/Pickup					
Grading Tread					
Cleaning/Repair of Drainage Structures					
Sign Repair					
Blaze Repair/Replace					
Vista Maintenance					



**Appendix XV·**  
**Virginia Tort Claims Act**



## Virginia Tort Claims Act

### Title 8.01

- 8.01-195.1 Short Title
- 8.01-195.2 Definitions
- 8.01-195.3 Commonwealth Liability for Damages
- 8.01-195.4 Jurisdiction of Claims
- 8.01-195.5 Settlement of Certain Cases
- 8.01-195.6 Notice of Claim
- 8.01-195.7 Statute of Limitations
- 8.01-195.8 Release of Further Claims
- 8.01-195.9 Claims Evaluation Program

§ 8.01-195.1

Short title

This article shall be known and may be cited as the "Virginia Tort Claims Act."

§ 8.01-195.2

Definitions

As used in this article:

"Agency" means any department, institution, authority, instrumentality, board or other administrative agency of the government of the Commonwealth of Virginia and any transportation district created pursuant to Chapter 32 (§ 15.1-1342 et seq.) of Title 15.1 and Chapter 630 of the 1964 Acts of Assembly.

"Employee" means any officer, employee or agent of any agency, or any person acting on behalf of an agency in an official capacity, temporarily or permanently in the service of the Commonwealth, or any transportation district, whether with or without compensation.

"School boards" as defined in §22.1-1 are not state agencies nor are employees of school boards state employees.

"Transportation district" shall be limited to any transportation district or districts which have entered into an agreement in which the Northern Virginia Transportation District is a party with any firm or corporation as an agent to provide passenger rail services for such district or districts while such firm or corporation is performing in accordance with such agreement.

Commonwealth, transportation district or locality liable for damages in certain cases

Subject to the provisions of this article, the Commonwealth shall be liable for claims for money only accruing on or after July 1, 1982, and any transportation district shall be liable for claims for money only accruing on or after July 1, 1986, on account of damage to or loss of property or personal injury or death caused by the negligent or wrongful act or omission of any employee while acting within the scope of his employment under circumstances where the Commonwealth or transportation district, if a private person, would be liable to the claimant for such damage, loss, injury or death. However, except to the extent that a transportation district contracts to do so pursuant to § 8.01-313, neither the Commonwealth nor any transportation district shall be liable for interest prior to judgment or for punitive damages. The amount recoverable by any claimant shall not exceed (i) \$25,000 for causes of action accruing prior to July 1, 1988, \$75,000 for causes of action accruing on or after July 1, 1988, or \$100,000 for causes of action accruing on or after July 1, 1993, or (ii) the maximum limits of any liability policy maintained to insure against such negligence or other tort, if such policy is in force at the time of the act or omission complained of, whichever is greater, exclusive of interest and costs.

Notwithstanding any provision hereof, the individual immunity of judges, the Attorney General, attorneys for the Commonwealth, and other public officers, their agents and employees from tort claims for damages is hereby preserved to the extent and degree that such persons presently are immunized. Any recovery based on the following claims are hereby excluded from the provisions of this article:

1. Any claim against the Commonwealth based upon an act or omission which occurred prior to July 1, 1982.
  - 1a. Any claim against a transportation district based upon an act or omission which occurred prior to July 1, 1986.
2. Any claim based upon an act or omission of the General Assembly or district commission of any transportation district, or any member or staff thereof acting in his official capacity, or to the legislative function of any agency subject to the provisions of this article.
3. Any claim based upon an act or omission of any court of the Commonwealth, or any member thereof acting in his official capacity, or to the judicial functions of any agency subject to the provisions of this article.
4. Any claim based upon an act or omission of an officer, agent or employee of any agency of government in the execution of a lawful order of any court.
5. Any claim arising in connection with the assessment or collection of taxes.
6. Any claim arising out of the institution or prosecution of any judicial or administrative proceeding, even if without probable cause.
7. Any claim by an inmate of a state correctional facility, as defined in § 8.01-1-1, unless the claimant verifies under oath, by affidavit, that he has exhausted his remedies under the adult institutional inmate grievance procedures promulgated by the Department of Corrections. The time for filing the notice of tort claim shall be tolled during the pendency of the grievance procedure.

8. Any claim arising from the failure of a computer, software program, database, network, information system, firmware or any other device, whether operated by or on behalf of the Commonwealth of Virginia or one of its agencies, to interpret, produce, calculate, generate, or account for a date which is compatible with the "Year 2000" date change.

Nothing contained herein shall operate to reduce or limit the extent to which the Commonwealth or any transportation district, agency or employee was deemed liable for negligence as of July 1, 1982, nor shall any provision of this article be applicable to any county, city or town in the Commonwealth or be so construed as to remove or in any way diminish the sovereign immunity of any county, city or town in the Commonwealth.

#### § 8.01-195.4

Jurisdiction of claims under this article; right to jury trial; service on Commonwealth or locality

The general district courts shall have exclusive original jurisdiction to hear, determine, and render judgment on any claim against the Commonwealth or any transportation district cognizable under this article when the amount of the claim does not exceed \$1,000, exclusive of interest and any attorneys' fees. Jurisdiction shall be concurrent with the circuit courts when the amount of the claim exceeds \$1,000 but does not exceed \$10,000, exclusive of interest and such attorneys' fees. Jurisdiction of claims when the amount exceeds \$10,000 shall be limited to the circuit courts of the Commonwealth. The parties to any such action in the circuit courts shall be entitled to a trial by jury.

In all actions against the Commonwealth commenced pursuant to this article, the Commonwealth shall be a proper party defendant, and service of process shall be made on the Attorney General. The notice of claim shall be filed pursuant to §8.01-195.6 on the Director of the Division of Risk Management or the Attorney General. In all such actions against a transportation district, the district shall be a proper party and service of process and notices shall be made on the chairman of the commission of the transportation district.

#### § 8.01-195.5

Settlement of certain cases

The Attorney General shall have authority in accordance with §2.1-127 to compromise and settle claims against the Commonwealth cognizable under this article.

The chairman of the commission for a transportation district against which a claim was filed pursuant to this article, or such other person as may be designated by the commission, shall have the authority to compromise, settle and discharge the claim provided (i) the proposed settlement and reasons therefor are submitted to the commission in writing and approved by its members or (ii) the settlement is made in accordance with a written policy approved by the transportation district commission for such settlements. The Director of the Division of Risk Management may adjust, compromise and settle claims against the Commonwealth cognizable under this article prior to the commencement of suit unless otherwise directed by the Attorney General.

### Notice of claim

Every claim cognizable against the Commonwealth or a transportation district shall be forever barred unless the claimant or his agent, attorney or representative has filed a written statement of the nature of the claim, which includes the time and place at which the injury is alleged to have occurred and the agency or agencies alleged to be liable. The statement shall be filed with the Director of the Division of Risk Management or the Attorney General within one year after such cause of action accrued if the claim is against the Commonwealth. If the claim is against a transportation district the statement shall be filed with the chairman of the commission of the transportation district within one year after the cause of action accrued. However, if the claimant was under a disability at the time the cause of action accrued, the tolling provisions of §8.01-229 shall apply. The claimant or his agent, attorney or representative shall, in a claim cognizable against the Commonwealth, mail the notice of claim via the United States Postal Service by certified mail, return receipt requested, addressed to the Director of the Division of Risk Management or the Attorney General in Richmond. The notice, in a claim cognizable against a transportation district, shall be mailed via the United States Postal Service by certified mail, return receipt requested, addressed to the chairman of the commission of the transportation district.

In any action contesting the filing of the notice of claim, the burden of proof shall be on the claimant to establish mailing and receipt of the notice in conformity with this section. The signed return receipt indicating delivery to the Director of the Division of Risk Management, the Attorney General, or the chairman of the commission of the transportation district, when admitted into evidence, shall be prima facie evidence of filing of the notice under this section. The date on which the return receipt is signed by the Director, the Attorney General, or the chairman shall be prima facie evidence of the date of filing for purposes of compliance with this section.

Claims against the Commonwealth involving medical malpractice shall be subject to the provisions of this article and to the provisions of Chapter 21.1 (§8.01-581.1 et seq.) of this title. However, the recovery in such a claim involving medical malpractice shall not exceed the limits imposed by § 8.01-195.3.

### § 8.01-195.7

#### Statute of limitations

Every claim cognizable against the Commonwealth or a transportation district under this article shall be forever barred, unless within one year after the cause of action accrues to the claimant the notice of claim required by § 8.01-195.6 is properly filed. An action may be commenced pursuant to § 8.01-195.4 (i) upon denial of the claim by the Attorney General or the Director of the Division of Risk Management or, in the case of a transportation district, by the chairman of the commission of that district or (ii) after the expiration of six months from the date of filing the notice of claim unless, within that period, the claim has been compromised and discharged pursuant to §8.01-195.5. All claims against the Commonwealth or a transportation district under this article shall be forever barred unless such action is commenced within eighteen months of the filing of the notice of claim.

The limitations periods prescribed by this section and §8.01-195.6 shall be subject to the tolling provision of §8.01-229 and the pleading provision of §8.01-235. Additionally, claims involving medical malpractice in which the notice required by this section and §8.01-195.6 has been given shall be subject to the provisions of §8.01-581.9. Notwithstanding the provisions of this section, if notice of claim against the Commonwealth was filed prior to July 1, 1984, any claimant so filing shall have two years from the date such notice was filed within which to commence an action pursuant to

§ 8.01-195.8

Release of further claims

Notwithstanding any provision of this article, the liability for any claim or judgment cognizable under this article shall be conditioned upon the execution by the claimant of a release of all claims against the Commonwealth, its political subdivisions, agencies, and instrumentalities or against the transportation district, and against any officer or employee of the Commonwealth or the transportation district in connection with, or arising out of, the occurrence complained of.

§ 8.01-195.9

Claims evaluation program

The Division of Risk Management of the Department of General Services and the Attorney General shall develop cooperatively an actuarially sound program for identifying, evaluating and setting reserves for the payment of claims cognizable under this article.

**Appendix XVI:  
Recreational Use Statute**

Duty of care and liability for damages of landowners to hunters, fishermen, sightseers, etc

A. For the purpose of this section:

"Fee" means any payment or payments of money to a landowner for use of the premises or in order to engage in any activity described in subsections B and C of this section, but does not include rentals or similar fees received by a landowner from governmental sources or payments received by a landowner from incidental sales of forest products to an individual for his personal use, or any action taken by another to improve the land or access to the land for the purposes set forth in subsections B and C of this section or remedying damage caused by such uses.

"Land" or "premises" means real property, whether rural or urban, waters, boats, private ways, natural growth, trees and any building or structure which might be located on such real property, waters, boats, private ways and natural growth.

"Landowner" means the legal title holder, lessee, occupant or any other person in control of land or premises.

B. A landowner shall owe no duty of care to keep land or premises safe for entry or use by others for hunting, fishing, trapping, camping, participation in water sports, boating, hiking, rock climbing, sightseeing, hang gliding, skydiving, horseback riding, foxhunting, racing, bicycle riding or collecting, gathering, cutting or removing firewood, for any other recreational use, or for use of an easement granted to the Commonwealth or any agency thereof to permit public passage across such land for access to a public park, historic site, or other public recreational area. No landowner shall be required to give any warning of hazardous conditions or uses of, structures on, or activities on such land or premises to any person entering on the land or premises for such purposes, except as provided in subsection D.

C. Any landowner who gives permission, express or implied, to another person to hunt, fish, launch and retrieve boats, swim, ride, foxhunt, trap, camp, hike, rock climb, hang glide, skydive, sightsee, engage in races, to collect, gather, cut or remove forest products upon land or premises for the personal use of such person, or for the use of an easement as set forth in subsection B does not thereby:

1. Impliedly or expressly represent that the premises are safe for such purposes; or
2. Constitute the person to whom such permission has been granted an invitee to whom a duty of care is owed; or
3. Assume responsibility for or incur liability for any intentional or negligent acts of such person or any other person, except as provided in subsection D.

D. Nothing contained in this section, except as provided in subsection E, shall limit the liability of a landowner which may otherwise arise or exist by reason of his gross negligence or willful or malicious failure to guard or warn against a dangerous condition, use, structure, or activity. The provisions of this section shall not limit the liability of a landowner which may otherwise arise or exist when the landowner receives a fee for use of the premises or to engage in any activity described in subsections B and C of this section. Nothing contained in this section shall relieve any sponsor or operator of any sporting event or competition including but not limited to a race or triathlon of the duty to exercise ordinary care in such events.

E. For purposes of this section, whenever any person enters into an agreement with, or grants an easement to, the Commonwealth or any agency thereof, any county, city, or town, or with any local or regional authority created by law for public park, historic site or recreational purposes, concerning the use of, or access over, his land by the public for any of the purposes enumerated in subsections B and C of this section, the government, agency, county, city, town, or authority with which the



agreement is made shall hold a person harmless from all liability and be responsible for providing, or for paying the cost of, all reasonable legal services required by any person entitled to the benefit of this section as the result of a claim or suit attempting to impose liability. Any action against the Commonwealth, or any agency, thereof, for negligence arising out of a use of land covered by this section shall be subject to the provisions of the Virginia Tort Claims Act (§8.01-195.1 et seq.). Any provisions in a lease or other agreement which purports to waive the benefits of this section shall be invalid, and any action against any county, city, town, or local or regional authority shall be subject to the provisions of §15.2-1809, where applicable.

 [Go to \(previous section\)](#) or [\(next section\)](#) or [\(General Assembly Home\)](#)

long list  
use to go  
wrong list

**Appendix XVII:  
Rules of the Trail &  
Trail Etiquette Samples**



**I·M·B·A**

INTERNATIONAL MOUNTAIN BICYCLING ASSOCIATION

# *Rules of the Trail*

Thousands of miles of dirt trails have been closed to mountain bicyclists. The irresponsible riding habits of a few riders have been a factor. Do your part to maintain trail access by observing the following rules of the trail, formulated by the International Mountain Bicycling Association (IMBA). IMBA's mission is to promote environmentally sound and socially responsible mountain biking.

**1. Ride on open trails only.** Respect trail and road closures (ask if not sure), avoid possible trespass on private land, obtain permits and authorization as may be required. Federal and state wilderness areas are closed to cycling. The way you ride will influence trail management decisions and policies.

**2. Leave no trace.** Be sensitive to the dirt beneath you. Even on open (legal) trails, you should not ride under conditions where you will leave evidence of your passing, such as on certain soils after a rain. Recognize different types of soils and trail construction; practice low-impact cycling. This also means staying on existing trails and not creating any new ones. Be sure to pack out at least as much as you pack in.

**3. Control your bicycle.** Inattention for even a second can cause problems. Obey all bicycle speed regulations and recommendations.

**4. Always yield trail.** Make known your approach well in advance. A friendly greeting (or bell) is considerate and works well; don't startle others. Show your respect when passing by slowing to a walking pace or even stopping. Anticipate other trail users around corners or in blind spots.

**5. Don't scare animals.** All animals are startled by an unannounced approach, a sudden movement, or a loud noise. This can be dangerous for you, others, and the animals. Give animals extra room and time to adjust to you. When passing horses use special care and follow directions from the horseback riders (ask if uncertain). Running cattle and disturbing wildlife is a serious offense. Leave gates as you found them, or as marked.

**6. Plan ahead.** Know your equipment, your ability, and the area in which you are riding -- and prepare accordingly. Be self-sufficient at all times, keep your equipment in good repair, and carry necessary supplies for changes in weather or other conditions. A well-executed trip is a satisfaction to you and not a burden or offense to others. Always wear a helmet.

# How To Prevent Trail Closures

An Education Paper  
International Mountain Bicycling Association (IMBA)  
P.O. Box 7578, Boulder, CO 80306-7578  
(303)545-9011 (303)545-9026 Fax

## **Prevention is Best**

Diffuse the build-up of pressures over potential closures before the crisis stage is reached. Face the issue squarely and plan appropriate early response.

1. Start weekend patrols to warn irresponsible riders that they are hurting everyone.
2. Start a safe and responsible mountain bike riding program (with shops, clubs, or schools).
3. Have local bicycle dealers distribute IMBA's "Rules of the Trail" and explain to their customers why trail etiquette matters.
4. Get involved with land and trail management.
5. Develop a long-term reputation for caring about the environment.
6. Foster the idea that dirt trails are not necessarily a public right of way for bikes; riding on dirt is a privilege.
7. Learn who controls the dirt access where you ride, and volunteer with groups to do trail maintenance.

## **Respect Other Trail Users**

1. Show a maximum of trail courtesy and respect to all trail users. We're all members of the trail family enjoying the quiet and natural beauty of the backcountry. We must learn to share.
2. Take the time to set a good example. Stop, dismount, and talk with other trail users. Our motivations are no different than those of other users regardless of mode of travel.
3. Show concern for a clean, quiet backcountry experience. Keep trails as natural as possible.
4. Show that you understand other trail user's fears, needs, and desires.

## **Organize!!**

1. Get a group together to further your interests and establish regular meeting times and places.
2. Develop a consensus on appropriate places to ride area and what is best for all concerned.
3. Communicate your concerns to other user groups and land managers. Learn about and use the political process.
4. Develop appropriate education/training programs to increase public awareness and support.
5. Adopt a trail and do other volunteer work.
6. Support IMBA and other conservation organizations. Find out what is working in other areas to provide or continue land access.
7. Don't become discouraged or bitter; democracy is sometimes slow, but persistence and a cooperative attitude will eventually pay off.
8. Develop ways to share and maintain scarce resources. Show you care by actions as well as words.

## **In Case of Imminent Crisis . . .**

1. Identify decision makers who will decide the outcome of the issue. Find out where and when public hearings will be. Develop a plan and work with it. Take action!!
2. Establish criteria for decisions:
  - a. If public safety is the problem, push for educational barricades and safety patrols.
  - b. If user input is wanted, do an analysis of trail users.
  - c. If affected voters must be mobilized, circulate a petition and begin a letter-writing campaign.
  - d. If there is a broad base of trail users, form a coalition with other user-groups who help in trail maintenance. Volunteer together for projects.
3. Ask decision makers if you and others can present oral and written testimony. If necessary, ask for a delay in hearings to gain time to take the actions above.
4. Mobilize your groups or organization. Hold meetings, attend hearings, provide information, etc.
5. Get those with an economic interest to back you: bike shops, resorts, tourist groups, newspapers, local businesses, etc. Let IMBA and other groups know what is happening.
6. Show respect and develop a responsible reputation. Learn from the process so that if you don't get what you want the first time, you will be better prepared in the future.

For additional copies of this paper, please contact IMBA at the above address or telephone number.

**Appendix XVIII:  
Trail Grade  
Calculation Details**

## Trail Grade Calculation

[Much of this was taken from SCA's *Lightly on the Land*, 1996, pp. 110-112]

Percent of grade =  $\text{rise} / \text{run}$

1. On the topographic map (lower margin) locate the contour interval denoting the vertical distance between the contour lines. Insert that number in the equation as the *rise*.
2. Select a potential percent of grade that does not exceed the maximum allowed in the specifications for the proposed trail. Insert that number in the equation as the *percent of grade*.
3. Solve for run by dividing rise by percent of grade
4. In the map margin, find the bar scale that is divided into feet. Use it as a reference to spread the divider points to the length of the run in your equation.
5. Set one point of the dividers on the map contour line where the trail will begin. Swing the dividers around in the direction that the trail will likely head, and rest the other point on the next higher or lower contour line. The gap between the points of the dividers represents on the map the approximate location of a route climbing or descending at your selected percent of grade.
6. Walk the dividers from the trailhead to the first control point, climbing or descending by always placing the free point of the dividers on the appropriate adjacent contour line. If the dividers come close to the first control point marked on your map, you will know that the percent of grade you have chosen is the reading to use when you begin the actual surveying in the field. If the dividers pass well above or below the first control point, you will need to try different percents of grade until you plot the best one for your trail.
7. Pencil in the workable route at the appropriate percent of grade on the map. Continue testing grades with dividers to connect the control points, until you plot the entire trail. The grade may vary between points.
8. When the terrain is step, you may not be able to plot a line that reaches a control point even at the highest percent of grade allowed. Explore other options such as contouring the trail around the head of a valley or behind a hillside, or even plotting a switchback. Make the trail segments leading to and from the switchback as long as possible to lessen the number of turns needed.

EX. At an 8 percent grade, a trail will rise a total of 8 feet in elevation for every 100 feet of run. If the interval between a map's contour lines is 40 feet, an 8 percent trail must have a run of 500 feet ( $40 = .08 \times 500$ ) to rise from one contour line to another.

# Appendix XIX.

## Sample Bench Design

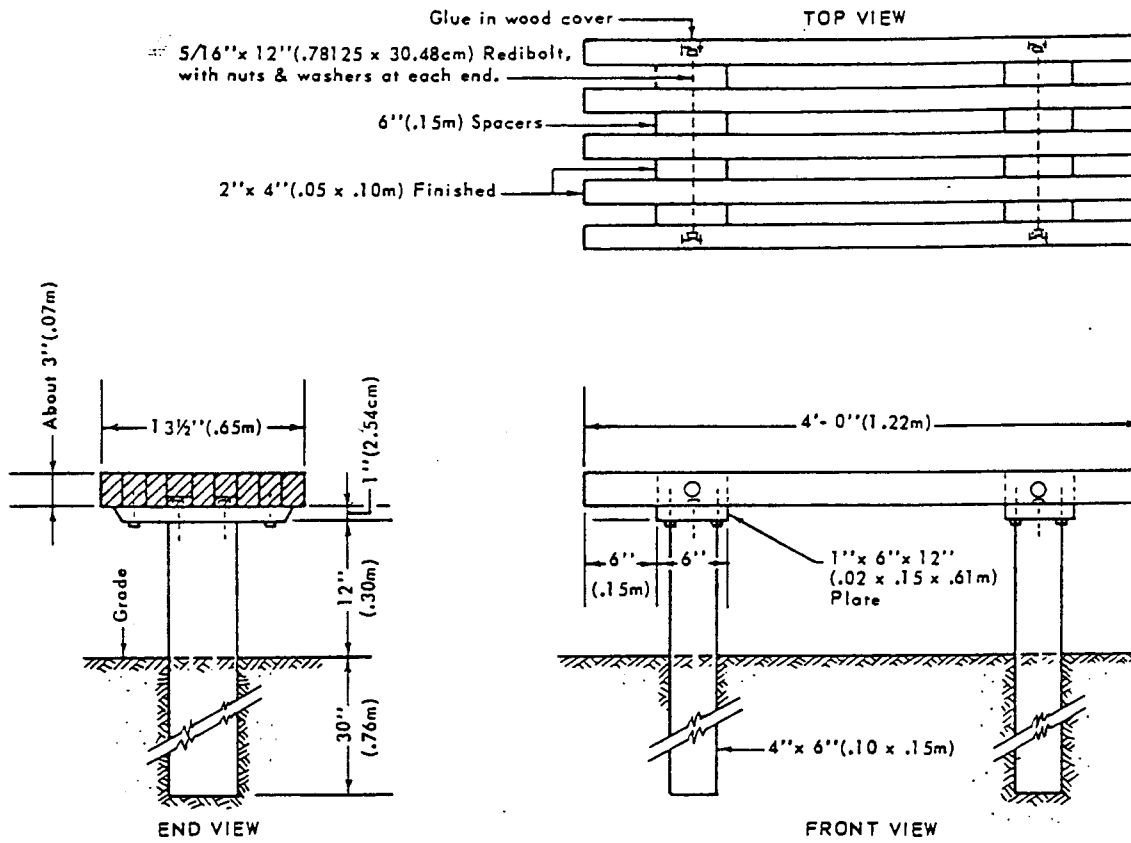



# **Appendix XX: Sample Kiosk Design**

RECOMMENDED BY:  
 APPALACHIAN TRAIL CONFERENCE  
 NPS APPALACHIAN TRAIL PROJECT OFFICE

DESIGN #1  
 LONG LASTING  
 BULLETIN BOARD

PRODUCTION  
 DRAWING NO. E. SMITH, L. GRIFFIN  
 100118 30 E. VALTON  
 CHECKED BY L. GRIFFIN  
 FILE NO./DATE 5041 2/20/74

REVISED BY M. SMITH  
 DATE 10/8 30 G. KIRCH  
 CHECKED BY W. VANHORN, A. BOWEN  
 FILE NO./DATE 5041 2/20/74

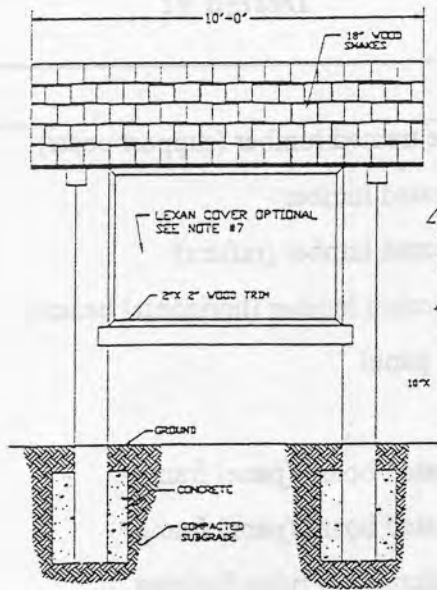

FRONT ELEVATION

SCALE: 3/4" = 1'-0"

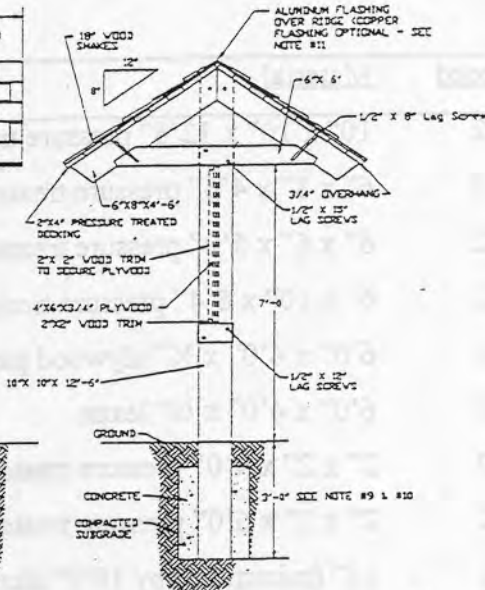

END ELEVATION

SCALE: 3/4" = 1'-0"

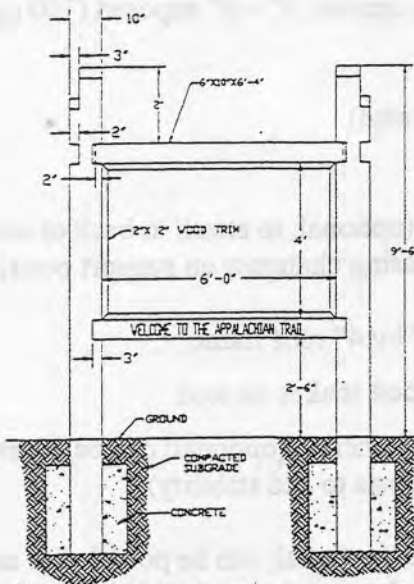

FRAMING DETAIL

SCALE: 3/4" = 1'-0"

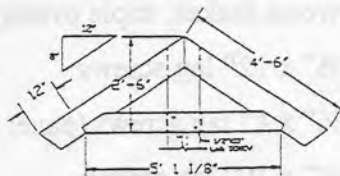

SIDE FRAMING DETAIL

SCALE: 3/4" = 1'-0"

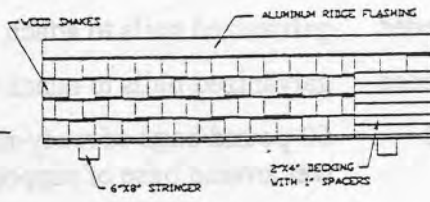

ROOF ASSEMBLY

SCALE: 3/4" = 1'-0"

NOTES

1. ALL WOOD SHOULD BE PRESSURE TREATED.
2. ALL HARDWARE AND NAILS SHALL BE GALVANIZED.
3. CEDAR WOOD SHAKES SHOULD BE APPROXIMATELY 18" X 1/2" HANDSPLIT WITH A 5 1/2" EXPOSURE.
4. FINISH SHOULD BE NATURAL.
5. STANDARD SLAT SIGN SHOULD HAVE APPROXIMATELY 2" LETTERS - "WELCOME TO THE APPALACHIAN TRAIL". WOOD ROUTED OR WHITE REFLECTIVE PAINT.
6. EASE ALL EXPOSED EDGES.
7. LEXAN COVER FOR PLYWOOD IS OPTIONAL. ATTACH 2" X 2" WOOD TRIM TO OUTSIDE EDGE OF LEXAN WITH 1/4" LAG SCREWS. ATTACH LEXAN TO PANEL AT TOP WITH 3" X 3" HINGES OR COMPARABLE SIZE DOOR HINGES.
8. OPTIONAL: 5/8" REBAR MAY BE ATTACHED TO BACK OF 10"X10" SUPPORT POSTS TO DETER VANDALS.
9. IN NORTHERN LOCATIONS, SINK SUPPORT POSTS TO A MINIMUM DEPTH OF 4'.
10. IF CONCRETE WILL NOT BE USED AROUND SUPPORT POSTS (FOOTERS), INCREASE DEPTH AN ADDITIONAL 1'0".
11. OPTIONAL: USE COPPER FLASHING EXPOSED 1" ON EITHER SIDE FROM UNDER SHAKE CAP. (COPPER WASH ON ROOF HELPS PREVENT MOLD AND MILDEW)

(NOT TO SCALE)

**Materials List**  
**Long-Lasting Bulletin Board**  
**Design #1**

# Needed	Material	Approximate Cost
2	10" x 10" x 12'6" pressure treated lumber (support posts)	\$260.00
4	6" x 8" x 4'6" pressure treated lumber	\$100.00
2	6" x 6" x 5'0" pressure treated lumber (rafters)	\$40.00
2	6" x 10" x 6'4" pressure treated lumber (horizontal beams)	\$100.00
1	6'0" x 4'0" x 3/4" plywood panel	\$20.00
1	6'0" x 4'0" x 1/4" lexan	\$160.00
2	2" x 2" x 4'0" pressure treated board (panel frame)	\$5.00
2	2" x 2" x 6'0" pressure treated board (panel frame)	\$5.00
	15" (minimum) by 10'0" aluminum ridge flashing	\$10.00
approx. 18	2" x 4" pressure treated boards (roof frame)	\$50.00
as needed	wood shakes, triple overlay, approx. 5" - 6" exposed (100 sq. ft.)	\$150.00
12	1/2" x 12" lag screws	\$25.00
18	1/4" x 4" lag screws (panel frame)	\$5.00
8	1/2" x 10" lag screws	\$15.00
2	5/8" x 3'0" rebar minimum (optional; to attach to back or side of posts to deter vandals from using chainsaw on support posts)	\$5.00
as needed	galvanized nails to attach 2" by 4" roof frame	\$5.00
as needed	galvanized nails to attach wood shakes on roof	\$5.00
12	60-pound bags of ready-mix concrete (optional; can be poured dry or wet around base of support posts to add stability)	\$35.00
8	12" bridge spikes or lag bolts (optional; can be pounded or nailed near base of support posts, below grade, to add stability)	\$5.00
Total Cost:		\$1000.00

note: costs are estimates only; prices may vary significantly by locale

note: larger-dimension lumber may have to be special-ordered from a sawmill

RECOMMENDED BY:  
 APPALACHIAN TRAIL CONFERENCE  
 NPS APPALACHIAN TRAIL PROJECT OFFICE

DESIGN #2  
 ECONOMIC  
 BULLETIN BOARD

PRODUCTION  
 DRAWING BY: E. HENRI, A. GRIFFIN  
 CHECKED BY: L. VANDER  
 DATE: \_\_\_\_\_  
 SHEET NO.: \_\_\_\_\_

NOTED BY: K. MANN  
 CHECKED BY: E. HENRI  
 DATE: \_\_\_\_\_  
 SHEET NO.: \_\_\_\_\_

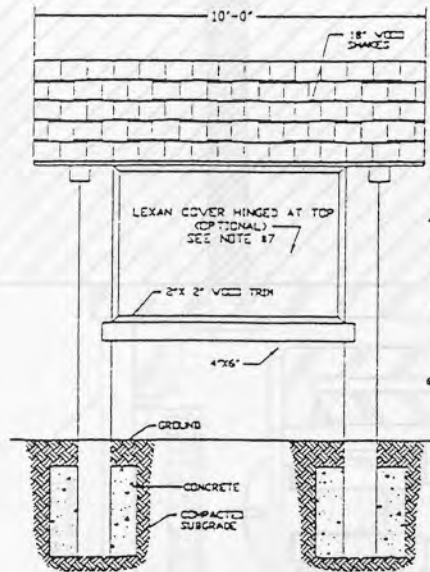

FRONT ELEVATION

SCALE: 3/4" = 1'-0"

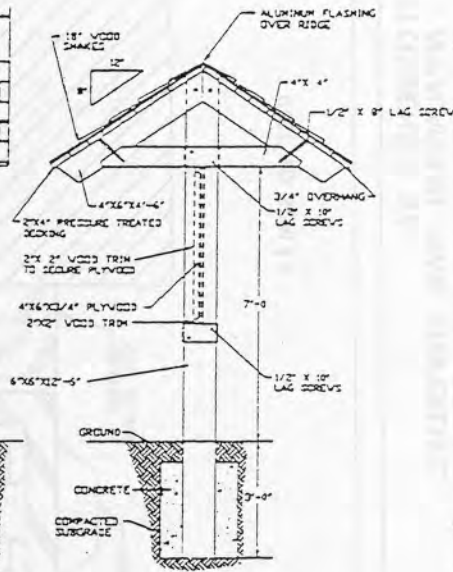

END ELEVATION

SCALE: 3/4" = 1'-0"

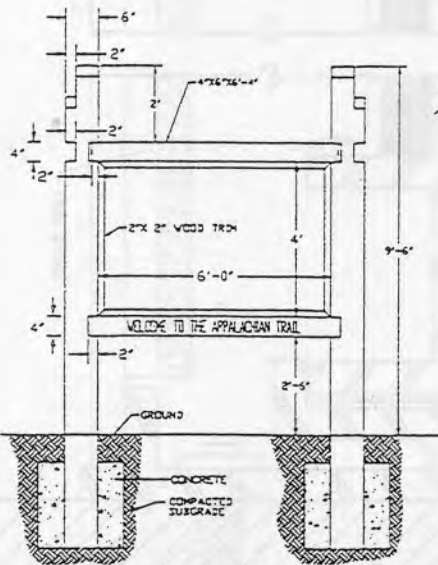

FRAMING DETAIL

SCALE: 3/4" = 1'-0"

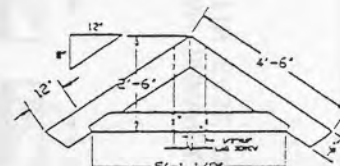

SIDE FRAMING DETAIL

SCALE: 3/4" = 1'-0"

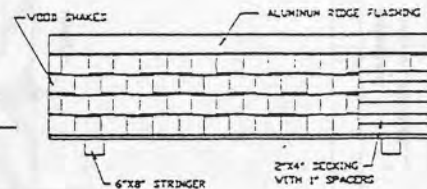

ROOF ASSEMBLY

SCALE: 3/4" = 1'-0"

(NOT TO SCALE)

NOTES:

1. ALL WOOD SHOULD BE PRESSURE TREATED.
2. ALL HARDWARE AND NAILS SHALL BE GALVANIZED.
3. CEDAR WOOD SHAKES SHOULD BE APPROXIMATELY 18" X 1/2" HANDSPLIT WITH A 5 1/2" EXPOSURE.
4. FINISH SHOULD BE NATURAL.
5. STANDARD FLAT SIGN SHOULD HAVE APPROXIMATELY 2" LETTERS - "WELCOME TO THE APPALACHIAN TRAIL". WOOD ROUTED OR WHITE REFLECTIVE PAINT.
6. EASE ALL EXPOSED EDGES.
7. LEXAN COVER FOR PLYWOOD IS OPTIONAL. ATTACH 2" X 2" WOOD TRIM WITH 1/4" LAG SCREWS.
8. OPTIONAL: 5/8" REBAR MAY BE ATTACHED TO BACK OF 10"X10" SUPPORT POSTS TO DETER VANDALS.
9. IN NORTHERN LOCATIONS, SINK SUPPORT POSTS TO A MINIMUM DEPTH OF 4'.
10. IF CONCRETE WILL NOT BE USED AROUND SUPPORT POSTS (FOOTERS), INCREASE DEPTH AN ADDITIONAL 1'.
11. OPTIONAL: USE COPPER FLASHING EXPOSED 1' ON EITHER SIDE FROM UNDER SHAKE CAP. (COPPER WASH ON ROOF HELPS PREVENT HOLD AND MILDEW)

Appalachian Trail Gateway Bulletin Board

THE DESIGN OF THIS BOARD EMPLOYED QUALITY MATERIALS TO INSURE LONG LIFE AND DURABILITY. THE BOARD IS DESIGNED TO BE USED IN A VARIETY OF ENVIRONMENTS AND IS SUITABLE FOR USE IN ALL WEATHER CONDITIONS.

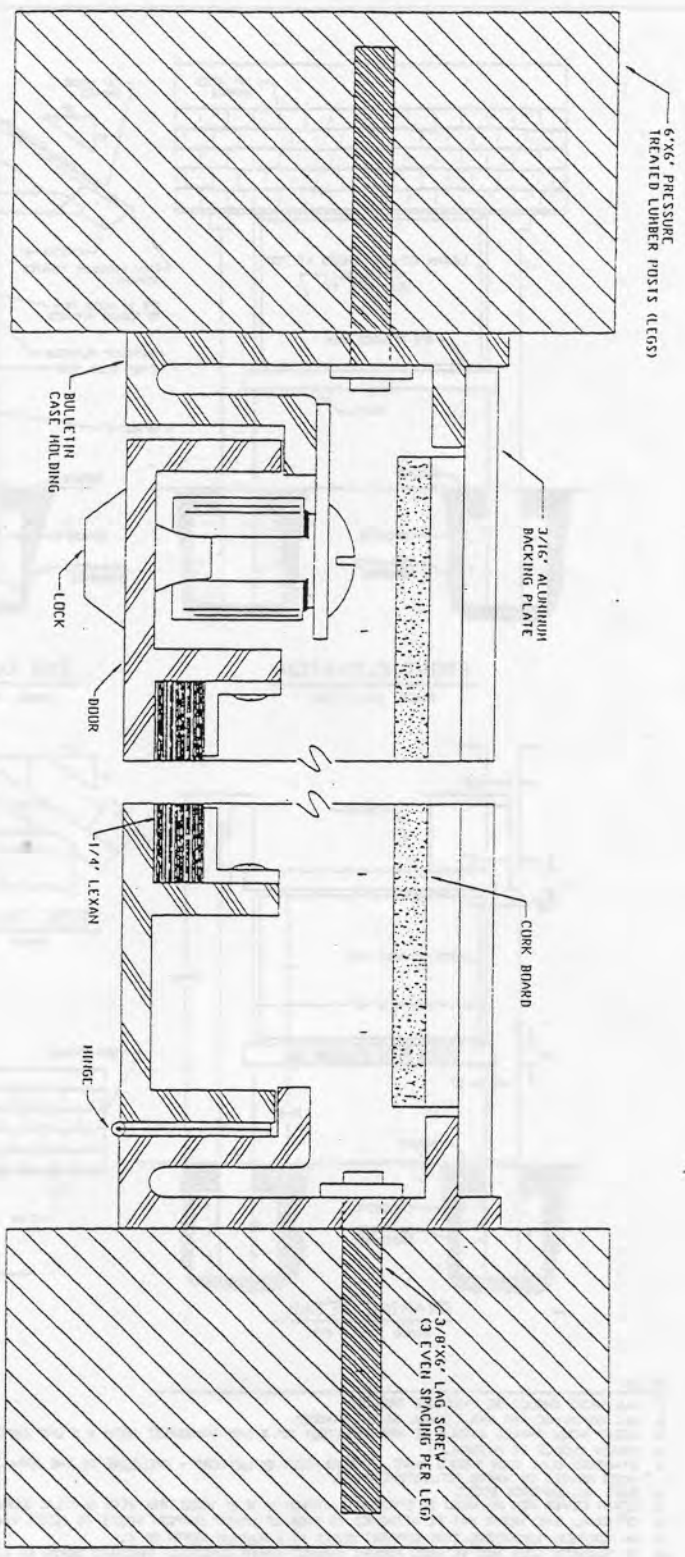

(NOT TO SCALE)

PLAN DRAWING  
BULLETIN CASE DETAIL

RECOMMENDED BY:  
APPALACHIAN TRAIL CONFERENCE  
NPS APPALACHIAN TRAIL PROJECT OFFICE

DESIGN #3  
VANDAL RESISTANT  
BULLETIN BOARD

PRODUCTION  
NUMBER 70-107X-100-100

PAGE 3 OF 3

DESIGNED BY: X. YANDEL  
DRAWN BY: E. MARRIS  
CHECKED BY: X. YANDEL, E. MARRIS  
FOR INFORMATION: MARY ELLIOTT

Appalachian Trail Gateway Bulletin Board

MR. VERNER W. HARRIS, TRAIL PROJECTS DIVISION  
 APPALACHIAN TRAIL COMMISSION  
 RECOMMENDED BY

BULLETIN BOARD  
 VANDAL RESISTANT  
 DESIGN #3

DATE: 11-18-71  
 DRAWN BY: [Signature]  
 CHECKED BY: [Signature]

NOT TO SCALE  
 PROJECT NO. 71-101-100  
 DRAWING NO. 71-101-100-100  
 SHEET NO. 1 OF 1

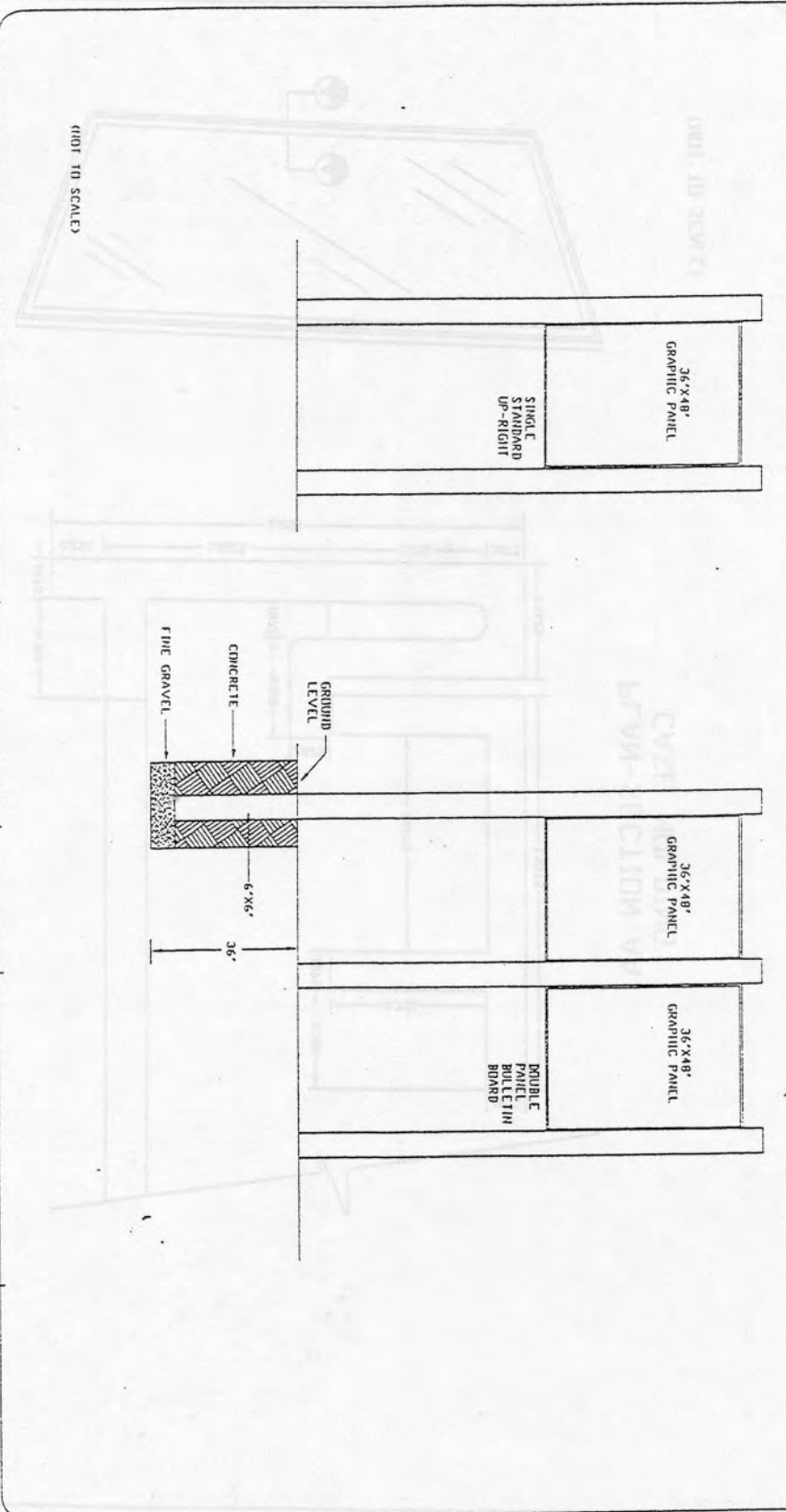

(NOT TO SCALE)

RECOMMENDED BY:  
 APPALACHIAN TRAIL CONFERENCE  
 NPS APPALACHIAN TRAIL PROJECT OFFICE

DESIGN #3  
 VANDAL RESISTANT  
 BULLETIN BOARD

PRODUCTION:  
 KNOWN BY: [Signature]  
 PAGE 1 OF 3

NOTING BY: V. MATHIAS  
 DRAWN BY: C. R. S. [Signature]  
 CHECKED BY: V. MATHIAS & G. S. [Signature]  
 DATE: 11-18-71

Appalachian Trail Gateway Bulletin Board

NO. 2 APPALACHIAN TRAIL PROJECT OFFICE  
 APPALACHIAN TRAIL CONFERENCE  
 RECOMMENDED BY:

BULLETIN BOARD  
 AVIATION RESISTANT  
 DESIGN #3

PRODUCTION  
 KNOWN TO: DESIGN NO.

APPROVED BY: V. YALOW  
 C. MULLA  
 X. VALON, E. ECK  
 THE MANUFACTURER: KATHI ZITZI

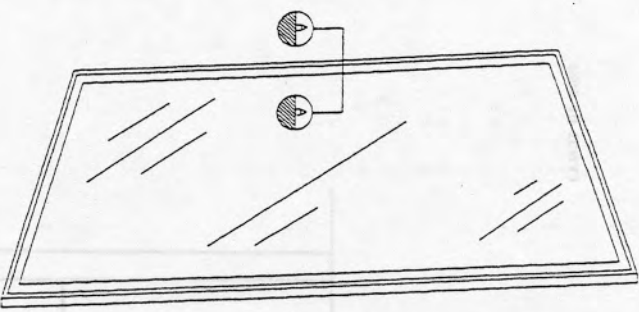

(NOT TO SCALE)

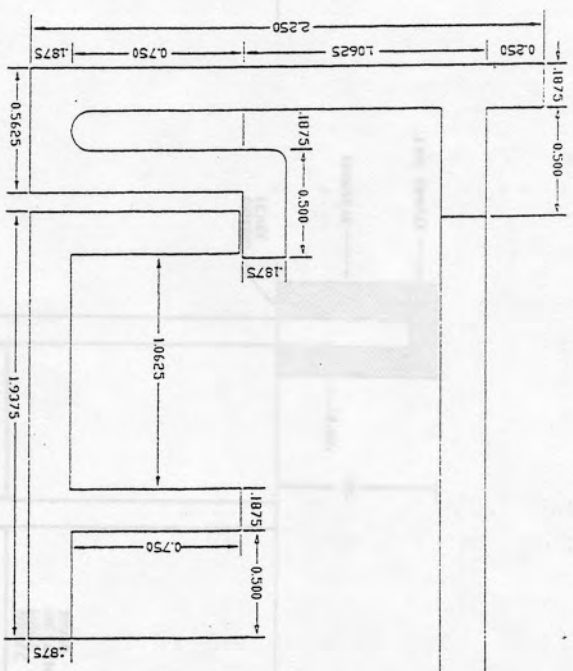

PLAN-SECTION AA  
 CASE MOLDING

RECOMMENDED BY:  
 APPALACHIAN TRAIL CONFERENCE  
 NPS APPALACHIAN TRAIL PROJECT OFFICE

DESIGN #3  
 VANDAL RESISTANT  
 BULLETIN BOARD

PRODUCTION  
 KNOWN TO: DESIGN NO.

APPROVED BY: V. YALOW  
 C. MULLA  
 X. VALON, E. ECK  
 THE MANUFACTURER: KATHI ZITZI

**Materials List**  
**Vandal-Resistant Bulletin Board**  
**Design #3**

Single Upright Panel Bulletin Board

<u># Needed</u>	<u>Material</u>	<u>Approximate Cost</u>
1	36" x 48" single standard upright panel bulletin board	\$800.00
12	60-pound bags of ready-mix concrete	\$35.00
Total Cost:		\$835.00

or:

Double Upright Panel Bulletin Board

<u># Needed</u>	<u>Material</u>	<u>Approximate Cost</u>
1	36" x 48" double upright panel bulletin board	\$1000.00
18	60-pound bags of ready-mix concrete	\$50.00
Total Cost:		\$1050.00

note: costs based on special-order through ATC; arrangements should be made through the regional office for your area.



# **Appendix XXI: Sample Gate Design**

PARK GATE FC.  
NEW RIVER TRAIL S.P.

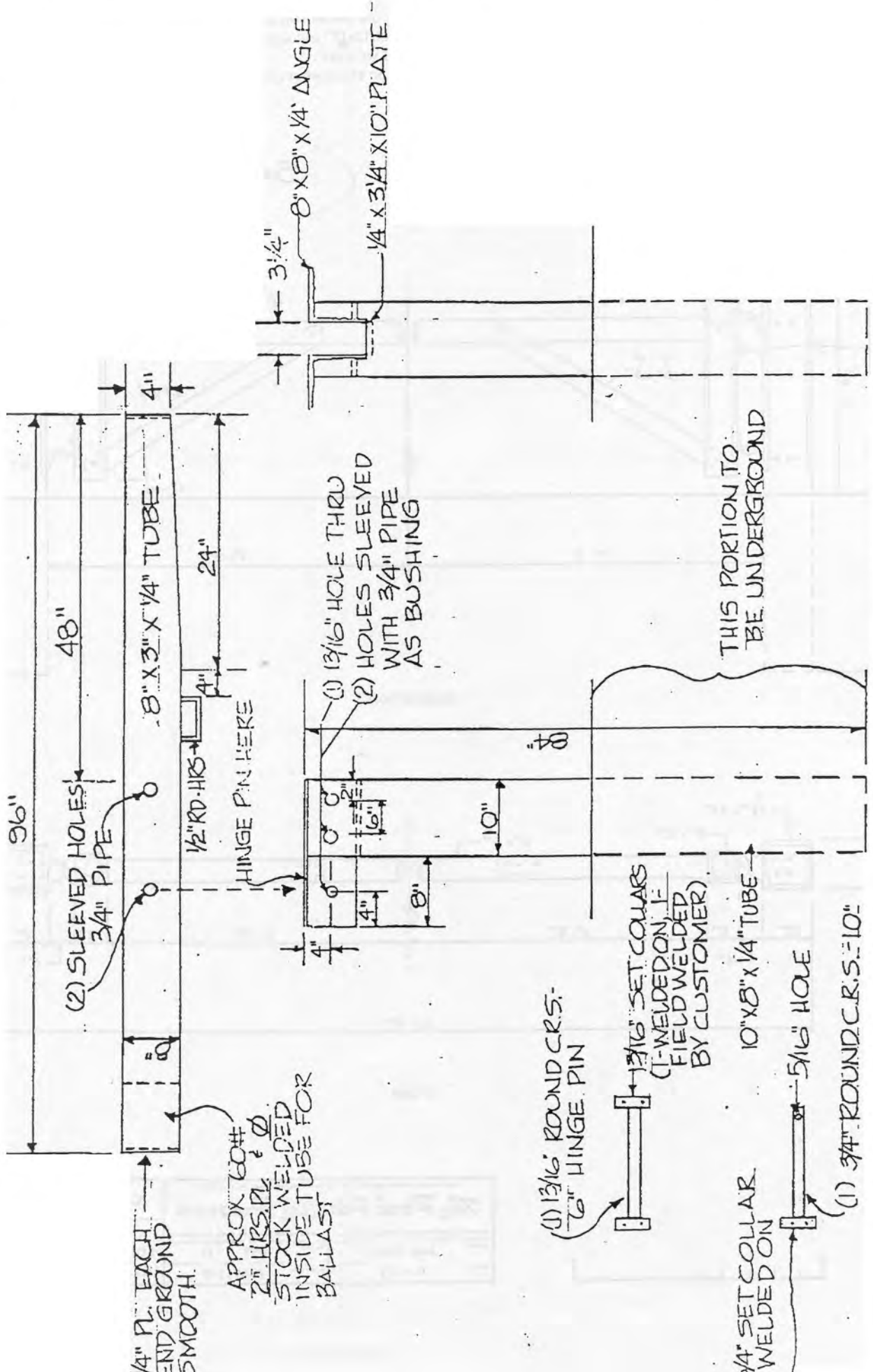

END OF ARM BALLASTED FOR BALANCE & EASE OF LIFTING, BUT NOT RAPID UPSWING.

ALL JOINTS WELDED SOLID  
ALL EDGES DE-BURRED  
PIVOT & LOCKING PIN WITH  
PIPE BRUSHING FOR SMOOTHNESS

NOT TO SCALE

Here is an "old stand-by" type of gate—  
 neat in appearance and thoroughly practical—  
 but with a new twist. Instead of the rail post  
 pivoting on a base pin, this one swings on two  
 in-line brackets hung on each 12x12" column.

Should move freely in all weather.

Locking may be by hasp or chain where the  
 rails meet.

Main Gates

Secondary Gates

Do Not  
 Bore!

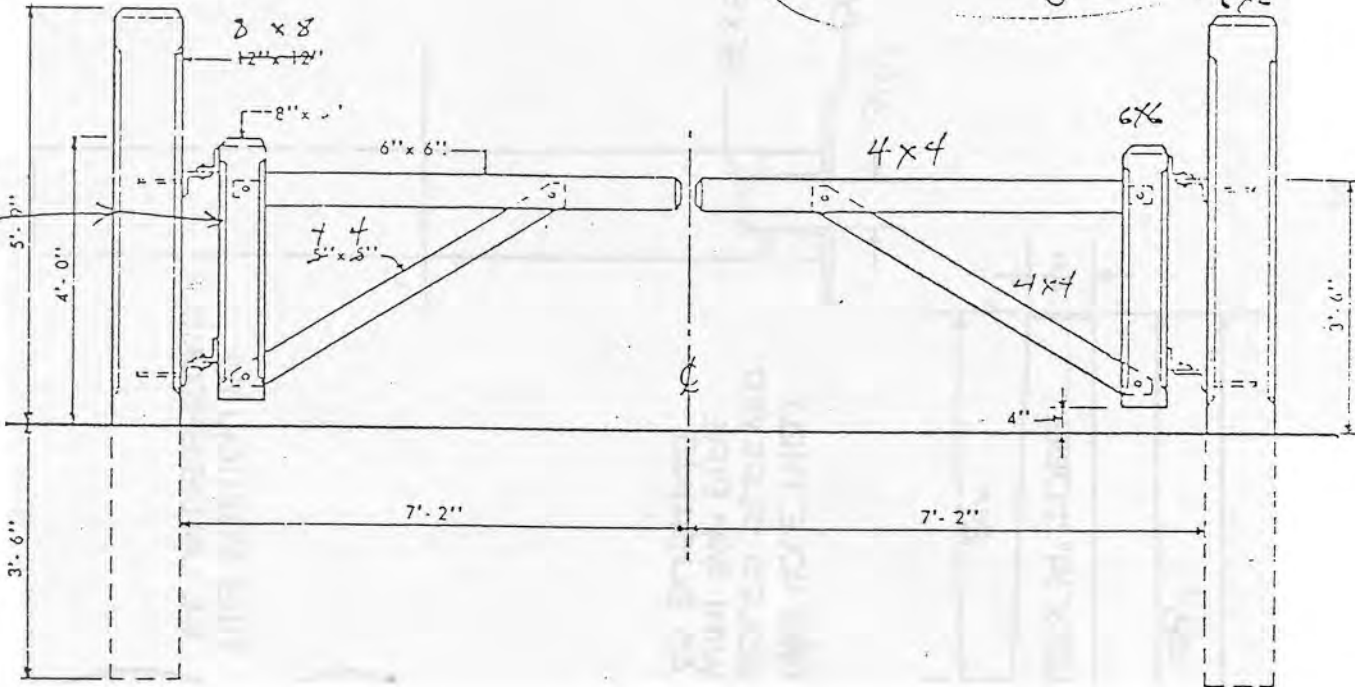

ELEVATION

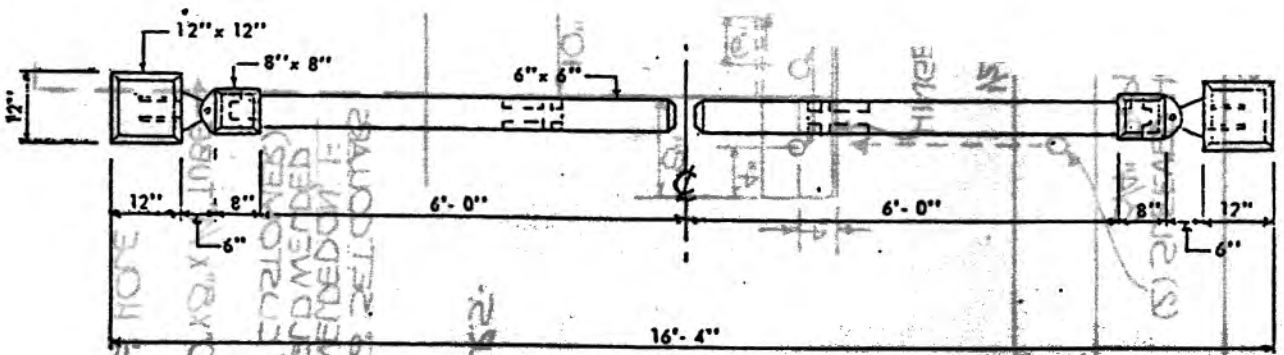

PLAN



UNITED STATES DEPARTMENT OF THE INTERIOR BUREAU OF LAND MANAGEMENT		CAMP ENTRANCE-GATE	
<i>The Park Practice Program</i>		Contributed by	
DATE	July 1966	NO.	499 II
NO.	P-7413	PROJECT	F-0913-P
		SOIL CONSERVATION DIV. REV.	
		U.S. Department of Agriculture	

# **Appendix XXII:**

## **Green Pages**

## Information and Technical Assistance

Accokeek Foundation  
3400 Bryan Point Road  
Accokeek, MD 20607  
Tel (301) 283-2113  
Fax (301) 283-2049

Advisory Council on Historic Preservation  
1100 Pennsylvania Ave., NW, # 809  
Washington, DC 20240  
Tel (202) 786-0503

American Farmland Trust  
1920 N. Street, NW 400  
Washington, D.C. 20036  
Tel (202) 659-5170

American Hiking Society  
Silver Spring, MD  
Tel (301) 565-6704  
URL <http://www.americanhiking.org>

Appalachian Trail Conference  
P.O. Box 807  
Harpers Ferry, WV 25425-0807  
Tel (304) 535-6331  
Fax (304) 535-2667

US Army Corps of Engineers  
Baltimore District Office  
P.O. Box 1715  
Baltimore, MD 21203  
Tel (410) 962-2809  
Fax (410) 962-3660  
URL <http://www.nab.usace.army.mil>

US Army Corps of Engineers  
Huntington District  
Attn: OR-FS  
502 8th Street  
Huntington, WV 25701  
Tel (304) 529-5710  
Fax (304) 529-5085

US Army Corps of Engineers  
Norfolk District  
Attn: Regulatory Branch  
803 Front Street  
Norfolk, VA 23510  
Tel (757) 441-7652  
Fax (757) 441-7678

US Army Corps of Engineers  
Wilmington District  
69 Darlington Avenue  
P.O. Box 1890  
Wilmington, NC 28402  
Tel (910) 251-4626  
Fax (910) 251-4946

Association for the Preservation of Civil War Sites  
11 Public Square, Suite 200  
Hagerstown, MD 21740  
Tel (301) 665-1400  
Fax (301) 665-1416  
URL [www.apcws.com](http://www.apcws.com)

Burwell-van Lennep Foundation  
P.O. Box 245  
Millwood, VA 22646  
Tel (540) 837-1353  
Fax (540) 837-1352

CBF - Tappahannock Office  
Va. Cons. Lands Program  
P. O. Box 220  
Tappahannock, VA 22560  
Tel (804) 443-5629  
Fax (804) 443-1993

Chesapeake Bay Local Assistance Department  
701 Eighth Street Office Building  
Richmond, VA 23219  
Tel (804) 225-3440  
Fax (804) 225-3447

Chesapeake Bay Foundation  
1001 E. Main Street, Suite 710  
Richmond, VA 23219  
Tel (804) 780-1392  
Fax (804) 648-4011  
URL [www.savethebay.org](http://www.savethebay.org)

Citizens for a Better Eastern Shore  
P. O. Box 882  
Eastville, VA 23347

Civil War Trust  
2101 Wilson Boulevard, Suite 1120  
Arlington, VA 22201  
Tel (703) 516-4944  
Fax (703) 516-4947  
URL [www.civilwar.org](http://www.civilwar.org)

Conservation Fund, The  
1800 North Kent St., Suite 1120  
Arlington, VA 22209-2156  
Tel (703) 525-6300  
Fax (703) 525-4610

Conservation, Inc.  
550 East Main Street, Suite 508  
Norfolk, VA 23510  
Tel (757) 623-0777  
Fax (757) 623-2785

Fairfax Land Preservation Trust  
Packard Center  
4022 Hummer Drive  
Annandale, VA 22003  
Tel (703) 354-5093

Friends of Chesterfield's Riverfront  
P.O. Box 2158  
Chesterfield, VA 23832  
Tel (804) 796-6091  
Fax (804) 796-6092  
E-mail [riverfront@earthlink.net](mailto:riverfront@earthlink.net)

Friends of Dragon Run  
P. O. Box 882  
Gloucester, VA 23061  
Tel (804) 642-2283

Institute of Conservation Leadership  
2000 P St., NW, Suite 412  
Washington, DC 20036  
Tel (202) 466-3330

K-III Directory Corp.  
1735 Technology Dr., Suite 410  
San Jose, CA 95110  
Tel (800) 547-8753 x 6783  
Fax (408) 467-6789

James River Association  
P.O. Box 110  
Richmond, VA 23201  
Tel (804) 730-2898  
Fax (804) 730-8297

Land Trust Alliance  
1319 F St., NW  
Washington, DC 20004-1106  
Tel (202) 638-4725

Land Trust of Virginia  
7 East Market St., Suite 210  
Leesburg, VA 22176  
Tel (703) 771-1474

League of American Bicyclists (LAB)  
190 W Ostend St.  
Baltimore, MD 21130-3755  
Tel (410) 539-3399  
Fax (410) 539-3496  
Email [bikeleague@aol.com](mailto:bikeleague@aol.com)  
URL <http://www.bikeleague.org>

Mathews County Land Conservancy  
HCR 69, Box 17280  
Mathews, VA 23109  
Tel (804) 725-9685  
Fax (804) 725-9111

National Center for Nonprofit Boards  
2000 L St., NW, Suite 510  
Washington, DC 20036-4790  
Tel (202) 452-6262  
Fax (202) 452-6299  
Email [ncnb@ncnb.org](mailto:ncnb@ncnb.org)

National Bicycle and Pedestrian Clearinghouse  
1506 21st Street, NW  
Suite 210  
Washington, DC 20036  
Tel (800) 760-NBPC  
(202) 463-8405  
Fax (202) 463-6625

National Coalition for the New River  
P. O. Box 1107  
Jefferson, NC 28640  
Tel (910) 982-9090  
Fax same

National Park Service  
Rivers, Trails and Conservation Assistance Program  
US Custom House  
200 Chestnut St., Third Floor  
Philadelphia, PA 19106  
Tel (215) 597-7995  
Fax (215) 597-0932

National Register of Historic Places  
National Park Service, Mid-Atlantic Regional Office  
143 South Third St.  
Philadelphia, PA 19106  
Tel (215) 597-1581  
Fax (215) 597-0932

National Transportation Enhancement Clearinghouse  
1506 Twenty-first St., NW, Suite 210  
Washington, DC 20036  
Tel (888) 388-6832  
Fax (202) 463-0875  
Email [ntec@transact.org](mailto:ntec@transact.org)  
URL <http://www.transact.org/ntec.htm>

National Trust for Historic Preservation  
1785 Massachusetts Ave., NW  
Washington, DC 20036  
Tel (202) 673-4000

The Nature Conservancy  
1233A Cedars Court  
Charlottesville, VA 22903  
Tel (804) 295-6106  
Fax (804) 979-0370

Non-Profit Management Development Center  
LaSalle University  
1900 W. Olney Ave.  
Philadelphia, PA 19141-1199  
Tel (215) 951-1701  
Fax (215) 951-1488

Northern Neck Audubon Society  
P. O. Box 991  
Kilmarnock, Va 22482

Pennsylvania Greenways Partnership  
Pennsylvania Environmental Council  
600 North 2nd St., Suite 403  
Harrisburg, PA 17101  
Tel (717) 230-8044  
Fax (717) 230-8045  
Email [pec-hbg@ix.netcom.com](mailto:pec-hbg@ix.netcom.com)  
URL <http://www.libertynet.org/pecphila>

Piedmont Environmental Council  
P. O. Box 460  
Warrenton, Va 22186  
Tel (540) 347-2334  
Fax (540) 349-9003

Piedmont Environmental Council  
Charlottesville Office  
1111 Rose Hill Drive, Suite 1  
Charlottesville, VA 22903

Potomac Appalachian Trail Club  
118 Park Street, SE  
Vienna, VA 22180  
Tel (703) 242-0693  
Fax (703) 242-0968

Potomac Conservancy  
4022 Hummer Road  
Annandale, VA 22003  
Tel (703) 642-9880  
Fax (703) 642-9881

Rails-to-Trails Conservancy  
1100 Seventeenth St., NW, 10<sup>th</sup> Floor  
Washington, DC 20036  
Tel (202) 331-9696  
Fax (202) 331-9680  
URL <http://www.railtrails.org>

Rivanna Conservation Society  
P.O. Box 141  
Palmyra, VA 22963  
Tel (804) 589-7576

Roanoke Valley Greenways  
P.O. Box 29800  
Roanoke, VA 24018  
Tel (540) 776-7159  
Fax (540) 772-2108  
URL <http://www.greenways.org>

Scenic America  
801 Pennsylvania Ave., SE, Suite 300  
Washington, DC 20003  
Tel (202) 543-6200

Surface Transportation Board (STB)  
1201 Constitution Ave., NW  
Washington, DC 20423  
Tel (202) 927-6184

Transportation Enhancement Clearinghouse  
1100 17th Street, NW  
10th Floor  
Washington, DC 20036  
Tel (888) 388-6832  
(202) 463-0641  
Fax (202) 463-0875

Trust for Appalachian Trail Lands  
Appalachian Trail Conference  
P.O. Box 807  
Harpers Ferry, WV 25425  
Tel (304) 535-6331  
Fax (304) 535-2667  
URL [www.atconf.org](http://www.atconf.org)

Trust for Public Land  
666 Broadway  
New York, NY 10012  
Tel (212) 677-7171

Trust for Public Land  
666 Pennsylvania Avenue, SE  
Washington, DC 20003  
Tel (202) 543-7552

Valley Conservation Council  
P. O. Box 2335  
Staunton, VA 24401  
Tel (540) 886-3541  
Fax (540) 885-7314

Virginia Association of Soil and Water Conservation  
Districts  
7293 Hanover Green Drive  
Mechanicsville, VA 23111  
Tel (804) 559-0324

Virginia Bicycle Federation  
Rob Swennes, President  
P. O. Box 5621  
Arlington, VA 22205  
Tel (703) 532-6101  
E-mail [vabikefed@erols.com](mailto:vabikefed@erols.com)

Virginia Code Commission  
General Assembly Building  
910 Capital St.  
Richmond, VA 23219  
Tel (804) 786-3591  
Fax (804) 692-0625

Virginia Department of Conservation and Recreation  
203 Governor St., Suite 326  
Richmond, VA 23219  
Tel (804) 786-6140 for technical assistance  
Tel (804) 786-3218 for grants assistance  
Fax (804) 371-7899

Virginia Department of Forestry  
Attn: Paul Revell  
Urban and Community Forestry Coordinator  
900 Natural Resource Drive  
PO Box 3758  
Charlottesville, VA 22903  
Tel (804) 977-6555

Virginia Department of Game and Inland Fisheries  
4010 W. Broad Street  
PO Box 11104  
Richmond, VA 23230  
Tel (804) 367-1000  
Fax (804) 367-9147



Virginia Department of Historic Resources  
2801 Kensington Ave.  
Richmond, VA 23221  
Tel (804) 367-2391  
Fax (804) 367-2323

Virginia Department of Housing  
and Community Development  
Virginia Main Street Program  
The Jackson Center  
501 North 2nd Street  
Richmond, VA 23219-1321  
Tel (804) 371-7030

Virginia Department of Transportation  
Enhancement Program Office  
Robert Casada, Director  
1401 E. Broad St.  
Richmond, VA 23219  
Tel (804) 786-2921  
Fax: (804) 371-8719  
E-mail [casada\\_ro@vdot.state.va.us](mailto:casada_ro@vdot.state.va.us)

Virginia Department of Transportation  
Traffic Planning Division  
Bicycle Planning Office  
Attn: Susan Simmers  
1401 E. Broad St.  
Richmond, VA 23219  
Tel (804) 371-4869  
Fax (804) 225-4785  
E-mail [vabiking@vdot.state.va.us](mailto:vabiking@vdot.state.va.us)

Virginia Horse Council  
P. O. Box 72  
Riner, VA 24149  
Tel (540) 382-3071  
Fax (540) 382-3071

Virginia Outdoors Foundation  
Attn: Tamara Vance, Executive Director  
203 Governor's Street, #420  
Richmond, VA 23219  
Tel (804) 225-2147  
Fax (804) 371-4810

Virginia Outdoors Foundation  
Northern Virginia Office  
P.O. Box 322  
Aldie, VA 20105  
Tel (703) 327-6118  
Fax (703) 327-6444

Virginia Outdoors Foundation  
Charlottesville Office  
1010 Harris Street, #4  
Charlottesville, VA 22903  
Tel (804) 293-3423  
Fax (804) 293-3859

Virginia Registrar of Regulations  
General Assembly Building  
901 Capitol Street  
Richmond, VA 23219  
Tel (804) 786-3591

Virginia Trails Association  
P.O. Box 1132  
Ashland, VA 23005  
Tel (804) 798-4160  
Fax (804) 798-0433

Waterford Foundation  
P. O. Box 142  
Waterford, VA 22190  
Tel (540) 882-3018  
Fax (540) 882-3921

Western Virginia Land Trust  
P. O. Box 18102  
Roanoke, VA 24014

Williamsburg Land Conservancy  
P. O. Box 2000  
Williamsburg, VA 23187  
Tel (757) 565-0343  
Fax (757) 253-1652

## Funding Sources

### American Greenways Awards Program

- Sponsored by the Eastman Kodak Company
- The Kodak Awards Program will continue to provide small grants (from \$500 to \$2,500) for greenway and trail projects throughout America.
- Applications are accepted between March 1 and June 1. Awards are announced in early Fall.
- For more information, please contact Kevin Houlihan, American Greenways Coordinator at 703.525.6300 or email at [khoulihan@conservationfund.org](mailto:khoulihan@conservationfund.org).

### Rivers, Trails and Conservation Assistance Program

- Offers assistance to projects by lending technical skills in planning, design, and organizing.
- Works with landowners, local business owners and private groups to help define goals, resolve issues, and reach agreement on how important areas may be improved or protected.
- Projects are selected annually on a competitive basis.
- For more information, please contact the National Park Service Rivers, Trails and Conservation Assistance Program, 215.597.7995.

### Transportation Equity Act for the 21st Century (TEA-21)

- TEA-21 is a direct successor to ISTEA, leaving many of ISTEA's opportunities in tact and providing new opportunities for innovation.
- Pedestrian and bicycle facilities can be constructed with Congestion Mitigation Air Quality (CMAQ) allocations or Statewide/Regional Surface Transportation Program (STP) allocations.
- Enhancement Funds are now guaranteed, although a portion of the funds can be "transferred" to other more traditional transportation projects.
- Allocations for STP or CMAQ vary by region; contact local Virginia Department of Transportation (VDOT) Residency office for more information regarding eligibility, allocation and funding request deadlines.
- Enhancement Grant filing deadline is generally January 31st. Applications and additional information may be obtained by contacting 800.444.7832.

### Virginia Recreational Trails Fund Program

- Funded through TEA-21 and administered at the state level by the Department of Conservation and Recreation, Division of Planning and Recreation Resources.
- Program overview:
  1. motorized and non-motorized trail applications accepted;
  2. funding for 20% of project cost must come from applicant or sponsor;
  3. matching funds can include privately donated funds and fair market value of materials and services, including local parks and recreation work forces;
  4. projects that seek to maintain, improve and/or upgrade existing trails are encouraged.
- Application deadline: January 31. Request copy of application from Grants Administrator, Department of Conservation and Recreation, Division of Planning and Recreational Resources, 203 Governor Street, Suite 326, Richmond, VA 23219-2010.

### Virginia Environmental Endowment (VEE)

- Grants are awarded to universities, citizens groups, public agencies, schools and conservation organizations to improve the quality of the environment through education. The mission of the VEE is to involve all sectors of the community to prevent pollution and conserve natural resources.
- Grant proposals are accepted for the Virginia Program and the Virginia Mini-Grant Program.
- Application deadlines: April 15, August 15 and December 15. Contact the Virginia Environmental Endowment at PO Box 790, Richmond, VA 23218-0790 for application brochure. Or call (804) 644-5000. Or visit their website at <http://www.vee.org>.
- Virginia Program Grant Applications
  1. Sustainable Communities
  2. Water Quality Protection
- Virginia Mini-Grant Program Applications
  1. Environmental Education
  2. Water Quality Protection

## **Virginia Department of Forestry: Urban and Community Forestry Assistance Grants**

- Grant program is designed to encourage projects that promote tree planting and education related to developing sustainable urban forestry programs at the local level.
- Grants may be awarded to local governments, approved non-profit organizations, educational institutions, and others for proposal which meet some, or all of the program's objectives.
- Grant filing deadline is June 1 with notice approval by July 1.
- Contact Virginia Department of Forestry at 900 Natural Resource Drive, P.O. Box 3758, Charlottesville, VA 22903, or call Paul Revell, Urban and Community Forestry Coordinator 804.977.6555.

# **Appendix XXIII:**

## **Bibliography**

This bibliography lists publications by title.

Acquiring Rail Corridors: A How to Manual. Allen, Jeff and Iurino, Tom. Washington, DC: Rails-to-Trails conservancy, 1996.

AMC Field Guide to Trail Building and Maintenance. Proudman, R.D. and Rajala, R. Boston, MA: Appalachian Mountain Conference: 1984, Second Edition.

Appraising Easements: Guidelines for the Valuation of Historic Preservation and Conservation Easements. Washington, DC: National Trust for Historic Preservation, 1990, Second Edition.

Bicycle Facility Planning. Pinosof, Suzan Anderson and Musser, Terri. Planning Advisory Service Report #459. Chicago, IL: American Planning Association, October 1995.

Chronicle of Philanthropy, The. Washington, DC: The Chronicle of Higher Education.

Community Trails Handbook. Chadds Ford, PA: Brandywine Conservancy, 1997.

Conflicts on Multiple-Use Trails: Synthesis of the Literature and State of the Practice. Roger L. Moore. Washington, DC: Federal Highway Administration, 1994.

Conservation Easement Handbook, The: Managing Land Conservation and Historic Preservation Easement Programs. Diehl, Janet and Barrett, Thomas S. Washington, DC: The Land Trust Alliance and Trust for Public Land, 1988.

Conservation Design for Subdivisions: A Practical Guide to Creating Open Space Networks. Arendt, Randall G. Washington, DC: Natural Lands Trust, American Planning Association, and American Society of Landscape Architects, 1996.

Corridor Management for Pastureland Streams. Lalo, Julie and Lutz, Carl. Harrisburg, PA: PA Fish and Boat Commission, 1994.

Creating Successful Communities: A Guidebook to growth Management Strategies. Mantell, Michael A., Harper, Stephen F., Propst, Luther. Washington DC: The Conservation Foundation, 1990.

Economic and Social Benefits of Off-Road Bicycle and Pedestrian Facilities, The (Technical Brief). Washington, DC: National Bicycle and Pedestrian Clearing House, 1995.

Economic Impacts of Protecting Rivers, Trails and Greenway Corridors. Murray, Ray, et al. San Francisco, CA: Rivers, Trails and Conservation Assistance, National Park Service, Western Region, 1995, Fourth Edition.

Effect of Greenways on Property Values and Public Safety, The. Alexander, Leslee T. Denver, CO: The Conservation Fund and Colorado State Parks State Trails Program, 1994.

Environmental Grantmaking Foundations. Rochester, NY: Resources for Global Sustainability, Inc. Annual Directory.

Evaluating Scenic Resources (Technical Bulletin). Washington, DC: Scenic America, 1996.

Grass Roots Fundraising Book, The: How to Raise Money in Your Community. Flanagan, Joan. Chicago, IL: Swallow Press, 1982.

GreenPlan. GreenSpace Alliance of Southeastern Pennsylvania. Philadelphia, PA: Pennsylvania Environmental Council, 1997.

Greenways: A Guide to Planning, Design, and Development. Flink, Charles A. and Searns, Robert M., Washington, DC: Island Press, 1993.

Greenways for America. Little, Charles E., Baltimore, MD: Johns Hopkins University Press, 1995, Second Edition.

Guide to Public Relations for Nonprofit Organizations and Public Agencies. Martinez, Roberta Fultz, and Weiner, Roberta. Los Angeles, CA: The Grantsmanship Center, 1982.

Guiding Growth: Building Better Communities and Protecting Our Countryside. Coughlin, Robert E., et al. Philadelphia, PA: Pennsylvania Environmental Council, 1993, Third Edition.

How Greenways Work: A Handbook on Ecology. Labaree, J. M., Ipswich, MA: National Park Service and Atlantic Center for the Environment, 1992, Second Edition.

How to Clean Up Your Neighborhood and Keep It Clean. Greensburg, PA: Pennsylvania Cleanways.

How to Organize a Water Clean Up. Greensburg, PA: Pennsylvania Cleanways.

Impacts of Rail-Trails, The: A Study of Users and Nearby Property Owners from Three Trails. Moore, Roger L., et al. Washington, DC: Rovers, Trails and Conservation Assistance Program, National Park Service, 1992.

Intergovernmental Cooperation Handbook. Kurtz, Thomas S. Harrisburg, PA: Office of Local Government Services, 1996, Third Edition.

Land Conservation Through Public/Private Partnerships. Endicott, Eve (ed.). Washington, DC: Island Press with the Lincoln Institute of Land Policy, 1993.

Maintenance of Bicycle and Pedestrian Facilities (Technical Brief). Washington, DC: National Bicycle and Pedestrian Clearing House, 1995.

Modern Water Trails: A guide to Establishing and Maintaining Recreational Waterways on Fresh and Salt Water. Getchell, David R., Sr. North American Water Trails, Inc.

NPS Trails Management Handbook. Hooper, Lennon. Washington, DC: National Park Service, 1983.

Pocket List of Railroad Officials, The. San Jose, CA: K-III Directory Corporation, Quarterly.

Public Opinion Polling. Lake, Celinda C. Washington, DC: Island Press, 1987.

Public Participation in Public Decisions: New Skills and Strategies for Public Managers. Thomas, John C. San Francisco, CA: Josey-Bass Inc., 1995.

Resolving Trail User Conflicts (Technical Brief). Washington DC: National Bicycle and Pedestrian Clearing House, 1996.

Rural by Design: Maintaining Small Town Character. Arendt, Randall et al. Chicago, IL: American Planning Association, 1994.

Saving America's Countryside: A Guide to Rural Conservation. Stokes, Samuel N. et al. Baltimore, MD: The National Trust for Historic Preservation, 1989.

Secrets to Successful Rail-Trails. Karen-Lee Ryan and Winterich, Julie A. Washington, DC: Rails-to-Trails Conservancy, 1993.

Social Life of Small Urban Spaces, The. William H. White. Washington, DC: The Conservation Foundation, 1980.

Trails for the 21st Century: A Planning, Design, and Management Manual for Multi-Use Trails. Ryan, Karen-Lee. Washington, DC: Rails-to-Trials Conservancy, 1993.

Trail Design, Construction, and Maintenance. Appalachian Trail Conference