

# 1987 - Town of Pennington Gap

## Application Details

**Funding Opportunity:** 1446-Virginia Community Flood Preparedness Fund - Capacity Building/Planning Grants - CY23 Round 4  
**Funding Opportunity Due Date:** Nov 12, 2023 11:59 PM  
**Program Area:** Virginia Community Flood Preparedness Fund  
**Status:** Under Review  
**Stage:** Final Application

**Initial Submit Date:** Nov 10, 2023 8:10 PM  
**Initially Submitted By:** Tammy Franklin  
**Last Submit Date:**  
**Last Submitted By:**

## Contact Information

### Primary Contact Information

**Active User\*:** Yes  
**Type:** External User  
**Name\*:** Ms. Tammy Jo Franklin  
Salutation First Name Middle Name Last Name  
**Title:** Director of Parks and Recreation  
**Email\*:** [tammy.jo@townofpenningtonva.gov](mailto:tammy.jo@townofpenningtonva.gov)  
**Address\*:** 528 Industrial Road

Pennington Gap Virginia 24277  
City State/Province Postal Code/Zip

**Phone\*:** 276-393-0335 Ext.  
Phone  
### ### #####  
**Fax:** ### ### #####

**Comments:**

### Organization Information

**Status\*:** Approved  
**Name\*:** Town Of Pennington Gap  
**Organization Type\*:** City Government  
**Tax ID\*:** 54-6001501  
**Unique Entity Identifier (UEI)\*:** WPRBVMNLNBL6

**Organization Website:**

**Address\*:** 528 Industrial Road

Pennington Gap Virginia 24277-  
City State/Province Postal Code/Zip

**Phone\*:** 276-393-0335 Ext.  
### ### #####

**Fax:** ### ### #####

**Benefactor:**

**Vendor ID:**

**Comments:**

## VCFPF Applicant Information

### *Project Description*

**Name of Local Government\*:** Town of Pennington Gap

Your locality's CID number can be found at the following link: [Community Status Book Report](#)

**NFIP/DCR Community Identification Number (CID)\*:** 510087

If a state or federally recognized Indian tribe,

**Name of Tribe:**

**Authorized Individual\*:** Keith Harless  
First Name Last Name

**Mailing Address\*:** 528 Industrial Dr  
Address Line 1  
Address Line 2

Pennington Gap Virginia 24277  
City State Zip Code

**Telephone Number\*:** 276-523-1177

**Cell Phone Number\*:** 276-393-0335

**Email\*:** [keith.harless@townofpenningtonva.gov](mailto:keith.harless@townofpenningtonva.gov)

Is the contact person different than the authorized individual?

**Contact Person\*:** No

Enter a description of the project for which you are applying to this funding opportunity

**Project Description\*:**

Studies to aid in updating floodplain ordinances to maintain compliance with the NFIP, or to incorporate higher standards that may reduce the risk of flood damage. This must include establishing processes for implementing the ordinance, including but not limited to, permitting, record retention, violations, and variances.

Low-income geographic area means any locality, or community within a locality, that has a median household income that is not greater than 80 percent of the local median household income, or any area in the Commonwealth designated as a qualified opportunity zone by the U.S. Secretary of the Treasury via his delegation of authority to the Internal Revenue Service. A project of any size within a low-income geographic area will be considered.

Is the proposal in this application intended to benefit a low-income geographic area as defined above?

**Benefit a low-income geographic area\*:** Yes

Information regarding your census block(s) can be found at [census.gov](http://census.gov)



**Census Block(s) Where Project will Occur\*:** DC20BLK\_C51105

**Is Project Located in an NFIP Participating Community?\***: Yes

**Is Project Located in a Special Flood Hazard Area?\***: No

**Flood Zone(s) (if applicable):**

**Flood Insurance Rate Map Number(s) (if applicable):**

## Eligibility - Round 4

---

### Eligibility

Is the applicant a local government (including counties, cities, towns, municipal corporations, authorities, districts, commissions, or political subdivisions created by the General Assembly or pursuant to the Constitution or laws of the Commonwealth, or any combination of these)?

**Local Government\*:** Yes  
Yes - Eligible for consideration  
No - Not eligible for consideration

If the applicant is not a town, city, or county, are letters of support from all affected local governments included in this application?

**Letters of Support\*:** N/A  
Yes - Eligible for consideration  
No - Not eligible for consideration

Has this or any portion of this project been included in any application or program previously funded by the Department?

**Previously Funded\*:** No  
Yes - Not eligible for consideration  
No - Eligible for consideration

Has the applicant provided evidence of an ability to provide the required matching funds?

**Evidence of Match Funds\*:** N/A  
Yes - Eligible for consideration  
No - Not eligible for consideration  
N/A - Match not required

## Scoring Criteria for Capacity Building & Planning - Round 4

---

### Scoring

**Eligible Capacity Building and Planning Activities (Select all that apply) ? Maximum 100 points. To make multiple selections, Hold CTRL and click the desired items.**

**Capacity Building and Planning\*:** Long term maintenance strategy

**Is the project area socially vulnerable?** (based on [ADAPT Virginia's Social Vulnerability Index Score](#))

**Social Vulnerability Scoring:**  
Very High Social Vulnerability (More than 1.5)  
High Social Vulnerability (1.0 to 1.5)  
Moderate Social Vulnerability (0.0 to 1.0)  
Low Social Vulnerability (-1.0 to 0.0)  
Very Low Social Vulnerability (Less than -1.0)

**Socially Vulnerable\*:** Moderate Social Vulnerability (0.0 to 1.0)

**Is the proposed project part of an effort to join or remedy the community's probation or suspension from the NFIP?**

**NFIP\*:** Yes

**Is the proposed project in a low-income geographic area as defined below?**

"Low-income geographic area" means any locality, or community within a locality, that has a median household income that is not greater than 80 percent of the local median household income, or any area in the Commonwealth designated as a qualified opportunity zone by the U.S. Secretary of the Treasury via his delegation of authority to the Internal Revenue Service. A project of any size within a low-income geographic area will be considered.

**Low-Income Geographic Area\*:** Yes

Does this project provide ?community scale? benefits?

**Community Scale Benefits\*:** 25-49% of the census block

**Comments:**

## Scope of Work and Budget Narrative - Capacity Building and Planning - Round 4

### **Scope of Work - General Information**

Upload your Scope of Work

Please refer to Part IV, Section B. of the grant manual for guidance on how to create your scope of work

**Scope of Work Attachment\*:** [SCOPE OF WORK .docx](#)

**Comments:**

### **Budget Narrative**

**Budget Narrative Attachment\*:** [BUDGET.docx](#)

**Comments:**

## Scope of Work Supporting Information - Capacity Building and Planning

### **Scope of Work Supporting Information**

Describe identified resource needs including financial, human, technical assistance, and training needs

#### **Resource need identification\*:**

Locality Capacity-building to Prepare for Resilience Planning

The Town of Pennington Gap is submitting this grant application to the Virginia Community Flood Preparedness Fund (CFPF) in the Capacity Building and Planning category. The town seeks award from this category to fund two town employees in becoming Certified Floodplain Managers (CFMs), to hire a consultant who will conduct a scoping analysis of floodplain hydrology and mitigation priority needs in Pennington Gap that includes a flood mitigation project opportunity list in preparation for future flood resilience planning efforts. Project opportunities will align with and consider LENOWISCO Planning District Commission (PDC) planning documents such as the Comprehensive Plan and Hazard Mitigation Plan, as well as the Town's Greenway Survey and Lee County's Comprehensive Plan, to ensure cohesive alignment with current and future regional flood resilience objectives

Town Background & Needs Assessment

Officially incorporated in 1891, the Town of Pennington Gap is located in far southwest Virginia and is the most populous town in Lee County, home to approximately 1,600 residents. The Town of Jonesville, the county seat of Lee County, is located six miles west of Pennington Gap, while the Town of Big Stone Gap, in adjacent Wise County, is 16 miles to the east. U.S. Highways 58 and 421 and numerous secondary roads serve the Town.

Pennington Gap's history of mining and logging has left it uniquely vulnerable to natural disasters, including repeated flooding, especially along the North Fork of Wallen Creek along their recreational areas and near their town hall and police headquarters. Lee County has had 14 federally-declared disasters due to precipitation since 1977 in addition to numerous other flood events that did not qualify as federally-declared disasters. Flood waters are well-known to be unsafe, and the additional pollution stemming from extractive activities make it a priority to contain any floodwaters threatening buildings and residents. As a low-income community affected by periodic flooding, Pennington Gap provides an ideal community for investing in flood mitigation, including nature-based practices.

Describe the plan for developing, increasing, or strengthening knowledge, skills and abilities of existing or new staff. This may include training of existing staff, hiring personnel, contracting consultants or advisors

#### **Development of Existing or New Staff\*:**

Keith Harless is the Town Manager for Pennington Gap. He has served in this role for almost eight years and has overseen a myriad of projects in the town, including a town partnership with Virginia Clean Cities to conduct an extended test drive of an all-electric 2023 Chevrolet Bolt EUV as part of a larger regional project titled "Rural Reimagined: Building an EV Ecosystem and Green Economy for Transforming Lives in Economically Distressed Appalachia." Harless is also currently leading multiple economic revitalization efforts, such as the restoration of downtown brownfields buildings and the creation of a Center for the Trades technical training facility.

Tammy Jo Franklin is Pennington Gap's Parks and Recreation Director, having stepped into the role in early 2022. She has extensive experience with community engagement and development, having previously worked for the Town of Big Stone Gap and non-profit Mountain Empire Older Citizens, Inc. Franklin leads work involving the town's green spaces and recreational areas and is dedicated to providing safe outdoor recreation

opportunities that are conservation-focused and benefit the community in more ways than one.

Emma Kelly is the New Economy Field Coordinator with Appalachian Voices, a regional environmental justice nonprofit with an extensive history of community engagement, environmental conservation, and project administration. She is a trained community organizer who manages community outreach initiatives, facilitates regular community listening sessions and the New Economy Network, and works directly with other environmental justice organizations and coalitions. She has been working with Pennington Gap for almost a year and is familiar with federal, state, and regional development and climate resiliency initiatives.

Where capacity is limited by funding, what strategies will be developed to increase resources in the local government? (This may include work with non-governmental organization, or applying for grants, loans, or other funding sources)

**Resource Development Strategies\*:**

No current member of town staff is a Certified Floodplain Manager (CFM). Part of this funding request for capacity building is so that the Town may train and certify two staff members as CFMS. The Town has identified a training course at the FEMA Emergency Institute in Emmitsburg, MD that is offered in February, March, April, and September 2024. The cost will include travel, lodging, meals, and the training itself, although training will be free if staff is accepted at the Institute

Describe policy management and/or development plans

**Policy management and/or development\*:**

The Town of Pennington Gap plans to contract an engineering consultant to conduct the data collection, site assessment, and develop the priority project list for the referenced area. Other Town departments will assist the Consultant by providing all existing Town documents that pertain to the floodplains and wetlands area and future planning. Town staff will also engage other departments in discussion and input during the project list development process. Estimates for the scope of work and cost come from consultation with Hirschman Water and Environment, LLC; a contract has not yet been finalized and a final consultant decision will be made after notification of a successful CFPF grant award.

Describe plans for stakeholder identification, outreach, and education strategies

**Stakeholder identification, outreach, and education strategies\*:**

This project will engage and impact several key stakeholders, including town executive leadership, town employees, residents, county agency officials, public community organizations, and regional partners. Town government, including the Parks and Recreation Department and the local police department, and other stakeholders who regularly use the involved floodplains will be especially important during this process. Pennington Gap will also be partnering closely with regional non-profit Appalachian Voices during this process, which has an existing network of community members who will be invited to public meetings. In order to effectively engage all stakeholders during this process, Pennington Gap proposes to host a 30-day online public input period, as well as a public hearing during a regular town council meeting to solicit community feedback. The feedback will be reviewed by the Consultant, city staff, and Appalachian Voices to incorporate into the Community Flood Preparedness Scoping Plan.

## Budget

---

**Budget Summary**

**Grant Matching Requirement\*:**

LOW INCOME - Planning and Capacity Building - Fund 90%/Match 10%

\*Match requirements for Planning and Capacity Building in low-income geographic areas will not require match for applications requesting less than \$3,000.

I certify that my project is in a low-income geographic area: Yes

**Total Project Amount\*:** \$50,000.00

**REQUIRED Match Percentage Amount:** \$5,000.00

## BUDGET TOTALS

**Before submitting your application be sure that you meet the match requirements for your project type.**

**Match Percentage:** 9.09%  
Verify that your match percentage matches your required match percentage amount above.

**Total Requested Fund Amount:** \$50,000.00

**Total Match Amount:** \$5,000.00

TOTAL: \$55,000.00

**Personnel**

Description	Requested Fund Amount	Match Amount	Match Source
Training Class,	\$1,500.00	\$0.00	
Community Outreach Consultant Labor	\$817.00	\$0.00	
	<b>\$2,317.00</b>	<b>\$0.00</b>	

**Fringe Benefits**

Description	Requested Fund Amount	Match Amount	Match Source
Per Diem, Lodging	\$1,268.00	\$0.00	
	<b>\$1,268.00</b>	<b>\$0.00</b>	

**Travel**

Description	Requested Fund Amount	Match Amount	Match Source
Travel	\$1,179.00	\$0.00	
	<b>\$1,179.00</b>	<b>\$0.00</b>	

**Equipment**

Description	Requested Fund Amount	Match Amount	Match Source
No Data for Table			

**Supplies**

Description	Requested Fund Amount	Match Amount	Match Source
Exam, Dues,	\$1,360.00	\$0.00	
	<b>\$1,360.00</b>	<b>\$0.00</b>	

**Construction**

Description	Requested Fund Amount	Match Amount	Match Source
No Data for Table			

**Contracts**

Description	Requested Fund Amount	Match Amount	Match Source
Engineering Consultant Labor	\$41,376.00	\$5,000.00	
	<b>\$41,376.00</b>	<b>\$5,000.00</b>	

**Pre-Award and Startup Costs**

Description	Requested Fund Amount	Match Amount	Match Source
No Data for Table			

**Other Direct Costs**

Description	Requested Fun Amount	Match Amount	Match Source
Community Outreach	\$2,500.00	\$0.00	
	<b>\$2,500.00</b>	<b>\$0.00</b>	

## Supporting Documentation - General

### Supporting Documentation

Named Attachment	Required	Description	File Name	Type	Size	Upload Date
Detailed map of the project area(s) (Projects/Studies)						
FIRMette of the project area(s) (Projects/Studies)						
Historic flood damage data and/or images (Projects/Studies)						
A link to or a copy of the current floodplain ordinance						
Maintenance and management plan for project						
A link to or a copy of the current hazard mitigation plan		Lenowisco 2021 Hazard Mitigation Study	<a href="#">lenowisco_2021_hazard_mitigation_plan_for_public_review_02.11.2021.pdf</a>	pdf	22 MB	11/10/2023 07:59 PM
A link to or a copy of the current comprehensive plan		Town of Pennington Gap Comprehensive Plan	<a href="#">2022-PCGap-Comp-Plan-REVISED-DRAFT-FEB-002.pdf</a>	pdf	1022 KB	11/10/2023 07:48 PM
Social vulnerability index score(s) for the project area						
Authorization to request funding from the Fund from governing body or chief executive of the local government						
Signed pledge agreement from each contributing organization						
Maintenance Plan						
<i>Benefit-cost analysis must be submitted with project applications over \$2,000,000. In lieu of using the FEMA benefit-cost analysis tool, applicants may submit a narrative to describe in detail the cost benefits and value. The narrative must explicitly indicate the risk reduction benefits of a flood mitigation project and compares those benefits to its cost-effectiveness.</i>						
Benefit Cost Analysis						
Other Relevant Attachments		Town Of Pennington Gap Community Flood Preparedness Fund Grant Program	<a href="#">CID510087_PenningtonGap_CFPF.pdf</a>	pdf	12 MB	11/10/2023 07:53 PM

### Letters of Support

Description	File Name	Type	Size	Upload Date
The Pennington Gap Lions Club Letter of Support	<a href="#">Pennington Gap Lions Club.docx</a>	docx	12 KB	11/10/2023 08:06 PM

2  
0  
2  
2



## Town of Pennington Gap, Virginia Comprehensive Plan

Town of Pennington Gap  
528 Industrial Drive  
Pennington Gap, Virginia  
24277

(276) 546-1177

Adopted by the Town Council of  
Pennington Gap on:

**TOWN OF PENNINGTON GAP,**

**VIRGINIA**

**COMPREHENSIVE PLAN**

**YEAR 2040**

**VISION FOR THE FUTURE**

**Prepared for the Town Council of the Town of Pennington Gap, Virginia by  
the Town of Pennington Gap Planning Commission with technical assistance  
provided by the LENOWISCO Planning District Commission**

**Town of Pennington Gap  
Mayor and Council Members**

Larry W. Holbrook, Mayor

Jill Carson  
Gary McElyea  
Jeff Martin  
Terry Pope  
Jimmy Warner

**Town of Pennington Gap  
Planning Commission**

Thomas Beck  
Tim Carpenter  
Rev. John Grimm  
Jeff Martin  
Loretta See-Chairman



# Town of Pennington Gap, Virginia Comprehensive Plan

## Table of Contents

Introduction	4
Section I- Profile of Community	6
Community Facilities	6
Related Plan Activities	15
Environmental Characteristics	17
Population Characteristics	18
Economic Characteristics	20
Family Characteristics	21
Housing Characteristics	22
Social Characteristics	23
Section II- Goals and Objectives	25
Environmental Goals and Objectives	25
Transportation Goals and Objectives	25
Housing Goals and Objectives	26
Public Facility Goals and Objectives	26
Economic Growth Goals and Objectives	27
Implementation Goals and Objectives	27
Land Use Goals and Objectives	28
Section III- Implementation of Plan	29
Section IIII- Existing and Future Land Use Map	34

# INTRODUCTION

## LOCATION/HISTORY

The Town of Pennington Gap is located in far southwestern Virginia. The Town is situated in central Lee County, the southwestern most county in the Commonwealth, tucked between the neighboring states of Kentucky and Tennessee. The Town of Jonesville, the county seat of Lee County, is located six miles west of Pennington Gap, while the Town of Big Stone Gap, in adjacent Wise County, is 16 miles to the east. U.S. Highways 58 and 421 and numerous secondary roads serve the Town.

The Town of Pennington Gap came into existence with the extension of the Louisville and Nashville Railroad's Cumberland Valley Division in 1890. The Town is named for the mountain pass situated nearby. As far as can be determined, the name "Pennington" came from an early settler to the area. Soon after the coming of the railroad, the Town was incorporated in 1892.

## PURPOSE OF THE PLAN

In accordance with section 15.2.2223 of the Code of Virginia, "The comprehensive plan shall be general in nature, in that it shall designate the general or approximate location, character, and extent of each feature shown on the plan and shall indicate where existing lands or facilities are proposed to be in use...Such plan, with accompanying maps, plats, charts, and descriptive matter shall show the planning commission's long range recommendations for the general development of the territory covered by the plan. It may include, but need not be limited to:

- The designation of areas for various types of public and private development and use...
- The designation of a system of transportation facilities...
- The designation of a system of community service facilities...
- The designation of historical areas and areas for urban renewal...
- An official map, a capital improvement program, a subdivision ordinance, and a zoning ordinance and zoning district map.

Further, as a minimum "in the preparation of a comprehensive plan, the local commission shall survey and study...use of land, characteristics and conditions of existing development, trends of growth or changes, natural resources, population factors, employment and economic factors, existing public facilities, drainage, flood control and flood damage prevention measures, transportation facilities, the need for housing..."

The Comprehensive Plan is prepared for design year 2040 for the Town of Pennington Gap. The Plan is intended to reflect current conditions and the current objectives of local officials and citizens of Pennington Gap, but will also set forth a series of long range objectives to allow for anticipated conditions occurring within the next twenty years.

## **PLAN ORGANIZATION**

The Pennington Gap Comprehensive Plan consists of three major sections.

The first section presents a profile of the community, including a brief review of related plans and activities that may have an influence on planning for the Town, physiographic and natural features, population characteristics and trends, local economy and employment data, and a housing and neighborhood analysis. The community profile serves as a basis for analysis of the physical development potential and the social economic well-being of the Town.

The second major section of the Plan presents the goals and objectives as determined by the existing land use, transportation, utilities and community facilities, and summarizes major findings of the background analysis in terms of planning factors that influence future development.

The third major section of the Plan deals with specific implementation of Plan recommendations through the zoning and subdivision ordinances and capital improvements program.

## **SECTION I - PROFILE OF COMMUNITY**

### **COMMUNITY FACILITIES**

#### **Parks and Recreation Areas**

Leeman Field offers numerous recreational opportunities. The park has basketball, tennis and volleyball courts, a walking path, swimming pool, skate park, pavilions, picnic tables and public restroom facilities. The park also has Little League baseball fields, ATV trail access, and RV park. The Town of Pennington Gap is responsible for the daily upkeep and maintenance of the park.

Nearby recreational opportunities are also available at Cumberland Bowl Park, located in the Town of Jonesville, and at the Wilderness Road State Park and the Jefferson National Forest.

#### **Libraries**

Libraries provide an important recreational and educational service for the public. These facilities can be used at no charge and are enjoyed by all age groups. Pennington Gap is served by the Lee County branch of the Lonesome Pine Regional Library System. The Lee County branch houses the second largest number of hardback volumes in the Lonesome Pine Regional Library network. The library also contains a large number of paperbacks, periodicals, records and CD's, microfilm and videos for public use. The library has seven full time employees and is open 54 hours per week.

#### **Town of Pennington Gap Water Treatment Plant**

The Pennington Gap water system is owned and operated by the Town. The principal source of water is the Powell River. The Town has a plant capacity of 2 million gallons per day.

The present system has approximately 1,300 connections located within the Town's boundaries. The system also provides water service to areas outside the Town's corporate limits, and wholesales water to Woodway, Dryden, St. Charles and the Lee County Public Service Authority.

#### **Town of Pennington Gap Wastewater Treatment Plant**

The Town of Pennington Gap has a wastewater treatment plant with a design capacity of 600,000 gallons per day. The system serves roughly 1,000 connections, both within and outside the corporate limits, plus handling effluent from Dryden, St. Charles, and the Lee County PSA.

#### **Public Safety**

The residents of Pennington Gap are served by three law enforcement agencies – the Pennington Gap Police Department, the Lee County Sheriff's Department, and the Virginia State Police. All three focus as separate law enforcement bodies, but exhibit complete cooperation in any situation calling for interdepartmental assistance.

The Pennington Gap Police Department has jurisdictional responsibility over all areas within the Town's corporate limits. The Department answers approximately 225 calls per month.

The Town is also a member of the Southwest Virginia Regional Jail Authority, which allows housing of inmates to take place at the regional jail facility in Duffield, in neighboring Scott County.

Pennington Gap also has a 20-member volunteer staffed fire department funded by the Town. The department answers an average of 150 calls per year within the Town's corporate limits and outside the town limits and is also primary agency for the Woodway and St. Charles areas as well. Pennington Gap Fire Department has a current ISO rating of Four inside the town limits and a Four B outside the corporate limits within a five-mile radius of both Pennington and Woodway.

The Town is also served by several different Volunteer Rescue Squads and one private Emergency Medical Service. These include C-Trans Medical Services and the Jonesville, St. Charles, Keokee, and Dryden Volunteer Rescue Squads.

### **Medical Services and Facilities**

Lee County health care facilities consists of a newly-reopened county hospital located in Pennington Gap, a county health department, and several private medical practices and health clinics. These include: Dr. Maloney Pennington & Jonesville Offices, Dr. Litton of Litton Family Medicine, Stephanie Purvis FNP, Mona Speak FNP of Family First Medical, ARH, Hopkins Medical, Stone Mountain Health Services, and Dr. Bell in Rose Hill.

In April 2014, the Lee County Board of Supervisors formed the Lee County Hospital Authority (LCHA) to head the effort to secure a new health care facility for the County. LCHA with overwhelming support from the citizens, municipalities, and elected officials began the laborious and lengthy process of trying to achieve this goal. Attracting a health care provider that could envision the benefit of serving a rural area was quite challenging. After a number of attempts and 8 years, their persistence was rewarded when Ballad Health agreed to reestablish a hospital in July 2021. The Lee County Hospital Authority now exists to help facilitate community concerns and needs with the hospital.

Since its opening in July 2021, the Lee County Community Hospital has provided crucial services for the residents of the county. The facility is a critical access hospital with 10 Emergency Rooms, 10 Inpatient/Observation Rooms, Radiology (to include CT, Ultrasound, and Digital Radiography), and a Laboratory.

The Lee County Health Department was built in 1971 and is located in Jonesville. It is one of three health departments in the LENOWISCO Health District. The Health Department is staffed with physicians, nurse practitioners, public health nurses, environmental health specialists, dentist, nutritionists, and support staff. They play a major role in protecting the health of all of the residents of Lee County. This is accomplished in a variety of ways, including preventative health measures, primary care services, and health promotion and education.

St. Charles Health Council Inc., doing business as Stone Mountain Health Services, provides primary health care for Pennington gap and Lee County, Virginia. Its patients include Medicaid and Medicare patients, private insurance patients, private pay patients, uninsured patients, and has a sliding fee scale for qualified low income persons. St. Charles Health Council, Inc. currently employs 5 doctors and 7 nurse practitioners in additions to benefits counselors, respiratory therapists, and behavioral health counselors to provide services. The Health Council services include:

- Routine, primary medical services for all ages.
- A Pharmacy Connect program which is a medication assistance program that provides cost-effective medicine for qualified persons who cannot afford medications.
- Behavioral Health Services
- The only federally funded Black Lung Clinic in the Commonwealth of Virginia to help miners and their families with health issues.
- A Layperson Legal Representation program that has helped miners and their families receive benefits in Worker’s Compensation claims.

There are clinics in Jonesville, Ewing, and St. Charles which operates the Black Lung Clinic.

### **Education**

Lee County is served by six elementary schools, two middle schools, and two high schools. Lee County also has one career and technical school.

Dryden Elementary School	Jonesville Middle School
Elk Knob Elementary School	Pennington Gap Middle School
Elydale Elementary School	
Flatwoods Elementary School	Lee High School
Rose Hill Elementary School	Thomas Walker High School
St. Charles Elementary School	

The Lee County Special Education program offers classes for educable mentally challenged, learning disabled, emotionally disturbed, speech- and visually-impaired, and also has a program designed for the hearing impaired.

### **Business Establishments**

The Town of Pennington Gap, though a small town, has a vast array of commercial establishments, businesses and local merchants. The Town is unique in that it has such a variety of commercial and retail establishments while still able to maintain a “small town” feel.

<b>Accounting/Tax Preparation</b>	
Bledsoe Bookkeeping & Tax Service	6413 Highway 421
Britton's Tax Service	106 Britton Drive
Diana Pope, CPA	116 Rogers Street
H&R Block	119 S Lakewood
Livesay Tax & Business Advisors	185 Redwood Ave
Parsons Accounting	42225 E Morgan Ave
<b>Auction</b>	
Fannon Land & Auction Company	42115 E Morgan Ave
Lee Auction Company	41091 Morgan Ave
<b>Banks</b>	
Farmers & Miners Bank	41526 W Morgan Ave
Powell Valley Bank	42180 E Morgan Ave
Lee Bank & Trust	41371 W Morgan Ave
<b>Beauty Salons</b>	
Envi Hair Studio	112 S Johnson Dr. Suite 101
Halos Hair Salon	41574 W Morgan Ave
Modernette	282 Westgate Mall Cir Ste 126
Sonny's Hair Care	5181 Highway 421
The Hairquarters	42065 E Morgan Ave
Valarie's Beauty Shop	41790 E Morgan Ave
<b>Car Repair/ Carwash/ Purchase</b>	
Central Automotive	41045 W Morgan Ave
Cumberland Automotive	42328 E Morgan Ave

Davis Transmissions	213 N Main St
Discount Motors/ Williams Towing	41279 W Morgan Ave
Family Tire & Wash House	40848 W Morgan Ave
Mark's Alignment & Wrecker Service	40578 W Morgan Ave
Xpress Carwash	40480 W Morgan Ave
<b>Child Care</b>	
Stepping Stones Academy	282 Westgate Mall Cir
<b>Churches</b>	
Beech Hill Baptist	299 Media St
Calvary Baptist Church	136 Westgate Mall Cir
Calvary Temple Church of God Mountain Assy	240 Forest Ave
First Baptist Church	41851 E Morgan Ave
First Christian Church	41481 W Morgan Ave
First United Methodist Church	41880 E Morgan Ave
Harber's Chapel Pentecostal Church	645 Joslyn Ave.
Pennington Church of Christ	282 Westgate Mall Cir Ste 121
Wells Chapel Church	224 Leona St
<b>Entertainment</b>	
Family & Friends "Friday Night Music"	116 Westgate Mall Cir
Lee Theatre	41676 W Morgan Ave
<b>Financial Investments</b>	
Edward Jones	41854 E Morgan Ave
<b>Fitness</b>	
Alter-Fit, LLC	282 Westgate Mall Cir Suite 102



Fusion Fitness	282 Westgate Mall Cir Suite 124
The Body Shop	218 Woodway Rd
<b>Florist</b>	
Norton Floral	40814 W Morgan Drive
<b>Funeral Homes</b>	
Mullins-Sturgill Funeral Home	298 Harrell St
Province Funeral Home	42098 E Morgan Ave
<b>Furniture Store</b>	
American Rental	40494 W Morgan Ave
EZ Rentals	205 River Bend Dr, Suite 106
Home Appliance & Furniture Company	41685 W Morgan Ave
<b>Gas Stations</b>	
Black Diamond #29	40554 W Morgan Ave
Lee's Food Mart	42149 E Morgan Ave
Food City Gas-n-Go	42164 E Morgan Ave
<b>Grocery Stores</b>	
Food City	205 River Bend Dr.
Grabeel IGA #3	41815 E Morgan Ave
<b>Insurance Agencies</b>	
Belcher, Doss & Williams	282 Westgate Mall Cir, Ste 125
C Group Insurance	42065 E Morgan Ave
Herndon Insurance	103 N Johnson Dr
InsurePro Nationwide Insurance	40539 W Morgan Ave

<b>Laundromat</b>	
Tidy K Laundromat	42106 E Morgan Ave
<b>Law Offices</b>	
Kinser Law	41342 W Morgan Ave
Williams Law Office	282 Westgate Mall Cir. Ste 124
<b>Hospital</b>	
Lee Regional Medical Center	127 Health Care Dr
<b>Medical Offices/Health Services</b>	
Family First Medical	41718 W Morgan Ave
Lee Family Dental	41830 E Morgan Ave
ARH Pennington Clinic	121 Stacy Dr
Cornerstone Therapy Services	40480 W Morgan Ave
Drs. Botts and Botts Optometrist	41372 W Morgan Ave
Haynes Chiropractic	123 N Johnson Dr Suite 202
In Home Care, Inc	185 Redwood Ave Suite 102C
Lee Health & Rehabilitation Center	208 Healthcare Dr
Moving Forward Physical Therapy	282 Westgate Mall Cir. Ste 104
Southern Home Respiratory & Equipment	205 River Bend Dr. Suite 104
Watson Dental Care	128 S Kentucky St
<b>Mental Health/ Counseling</b>	
Family Preservations Services	103 N Main Street
<b>Motel</b>	
Convenient Inn	171 Industrial Dr

<b>Other Establishments</b>	
American Concrete Group	631 Industrial Dr
American Tree Experts	171 N Kentucky St
East End Flea Market	42225 E Morgan Ave
Gap Mini Storage	200 N Kentucky Ave
Intoxalock	42328 E Morgan Ave
Lee Driving School	41670 W Morgan Ave
Lee School of Driving	316 Kentucky St
My County Radio	134 Main St
Old Dominion Power Co.	42311 E Morgan Ave
Powell Valley News	41798 E Morgan Ave
Thrift Shop	41633 W Morgan Ave
U. S. Post Office	41610 W Morgan Ave
USA Custom Solutions	134 Main St
Vacuum Outlet	6413 Highway 421
WSWV Radio Station	208 Westgate Mall Cir. Ste 101
<b>Pharmacies</b>	
John C. Marion Pharmacy	156 Combs Rd
Food City Pharmacy	205 River Bend Dr.
Pennington Pharmacy	41692 W Morgan Ave
Walgreens	5261 Highway 421
<b>Restaurants</b>	
Charly's	41751 W Morgan Ave
El Centenario	205 River Bend Dr.

Hardees	712 E Morgan Ave
Hong Kong	205 River Bend Dr, Suite 101
Huddle House #628	1526 West Morgan Ave
McDonalds	42357 E Morgan Ave
Nana's Country Kitchen	191 Industrial Dr
Pizza Hut	42585 E Morgan Ave
Rooster's Pub	131 Harrell St
Subway	42134 E Morgan Ave
Taco Bell	42487 E Morgan Ave
<b>Stores</b>	
Advance Auto Parts	42216 E Morgan Ave
American Ink	41822 E Morgan Ave
Antiques And More	41685 W Morgan Ave
Cuz's Tanning LLC	282 Westgate Mall Cir Suite 128
D&D's Smoke Shack	137 N. Johnson Dr, Suite 101
Family Dollar	205 River Bend Dr. Suite 103
First VA Pawn & Gold	41618 W Morgan Ave
Fur, Feathers & Fins	282 Westgate Mall Cir
Gab Shak Boutique	282 Westgate Mall Cir Ste 128
Kun Tree Apparel	109 N Main Street
Liberty Sport & Pawn	42259 E Morgan Ave
Look Twice	282 Westgate Mall Cir. Ste 118
O'Reilly Auto Parts	42216 E Morgan Ave
Pennington Armory	41709 W Morgan Ave

Pennington Yard Sale Store	282 Westgate Mall Cir Suite 119
Planet Vapor	40480 W Morgan Ave
Pullin Ink	179 N Kentucky St
Rise and Shine Spa and Boutique	282 Westgate Mall Cir Suite 117
Smokin' Guns	42244 E Morgan Ave
SoVa Gardens	42454 E Morgan Ave
Spears Drone Photography	283 Church Ave
The Dusty Monkey Auction House	41699 W Morgan Ave
Tri-State Metal	42454 E Morgan Ave
Verizon Wireless	41738 W Morgan Ave
Warner's Tobacco Outlet	282 Westgate Mall Cir Suite 128

## **RELATED PLANS AND ACTIVITIES**

Current and future planning efforts for the Town of Pennington Gap are influenced by planning activities of neighboring jurisdictions, Lee County, and regional agencies and authorities. Planning activities that affect the future development of Pennington Gap may range from the general, comprehensive plans of neighboring jurisdictions to the more specific site plans of industries or commercial developments. A brief review of related planning efforts and activities that may affect recommendations contained in the Town of Pennington Gap Comprehensive Plan is outlined as follows:

### **Lee County Comprehensive Plan**

The current Lee County Comprehensive Plan was prepared by the Lee County Planning Commission with assistance from the LENOWISCO Planning District Commission and was adopted by the County Board of Supervisors in 2003. Updated in 2022, county-wide statistics on physical characteristics, natural resources, the economy and population, land use and land use suitability, housing, public water and sewer, community facilities, and transportation form a basis for goals and objectives. These goals for development in the County, including its incorporated towns, provide a foundation for specific comprehensive plan recommendations.

### **Town of Pennington Gap Industrial Development Authority**

The Town of Pennington Gap established the Industrial Development Authority in 2012. The Town felt that an organization that focused solely on the needs and desires of the citizens of Pennington

Gap was greatly needed. The purpose of this organization is to provide assistance and financial support in order to attract businesses to locate or expand in the corporate limits of Pennington Gap. The IDA has been highly successful in helping to establish new businesses, provide support for existing businesses, and has been a catalyst for downtown revitalization. The IDA is currently in the planning stages for additional projects that will improve services and create new employment opportunities.

### **Lee County Economic Development Authority**

The Town of Pennington falls within the service area of the Economic Development Authority of Lee County Virginia. The Town of Pennington Gap Industrial Development Authority granted the County entity blanket authority for investment within the municipality as it sees fit. The purpose of the Authority shall be to promote and facilitate economic growth and development in Lee County by persuading manufacturing, industrial, and commercial enterprises to locate or remain in Lee County. Further, the Authority shall work to further the economic well-being of the citizens of Lee County by increasing their commerce and promoting their safety, health, welfare, and prosperity. The purpose shall also be to achieve the objectives established by the Authority to provide additional employment for all sectors of the Community, to promote economic stability and growth in the Community, and to assist the County in meeting its development objectives.

### **LENOWISCO Planning District Commission**

LENOWISCO was organized as a Planning District Commission in 1969 and currently operates under the Regional Cooperation Act, Title 15.2 of the 1950 Code of Virginia. Its primary purpose is to promote the orderly and efficient development of the physical, social and economic elements of the district by planning and assisting its three counties, one city and 15 incorporated towns to plan for the future. The Commission's Board of Directors is appointed by their respective localities. LENOWISCO is a multi-purpose association of its constituents for mutual benefits, and as such, operates a broadly based planning and economic development program for the region. The Commission formally plans for the orderly growth in the towns and surrounding areas of the District, while pursuing programs for the economic and social development of the entire area. LENOWISCO serves as the communicator between local governments and federal and state agencies, provides technical assistance and acts as a clearinghouse for public funding applications. The Commission also acts as a data bank, collecting and analyzing economic and environmental data for the region.

In compliance with the Regional Cooperation Act, one of the Commission's primary duties is the preparation and adoption of strategic plans for the region. These have included the 1970 Regional Land Use Plan, unanimously adopted by its local government in April 1973, and recently been updated. The Regional Water Quality Management Plan serves as a major policy document regarding water quality issues in the region. From 1972 to 1978, the Commission had special authority to implement the Overall Economic Development Program (OEDP) that promulgated a growth center concept. The district's counties and city organized the Duffield Development Authority to implement the industrial park at Duffield, a designated growth center. The LENOWISCO Comprehensive Economic Development Strategy, successor to the OEDP, helps guide regional community and economic development efforts and strategies. Over the years, LENOWISCO has been instrumental in providing direct services to the Town of Pennington Gap

in the procurement of federal/state funds for utility system, recreation and other improvements.

### **Virginia Department of Transportation**

The Virginia Department of Transportation revises its six-year plan each year. The Town of Pennington Gap is a participant in the Department's Rural Program and maintains projects on the list for implementation. The Virginia Department of Transportation 2020 plan outlines solutions and specific land use suggestions to relieve current traffic problems. The most up-to-date information regarding transportation project priorities for the Town of Pennington Gap can be found on the Virginia Department of Transportation web site at [www.vdot.gov](http://www.vdot.gov).

### **ENVIRONMENTAL CHARACTERISTICS**

Pennington Gap's natural resources include topography, climate, and geological, natural and hydrological features. Development activities are often influenced by natural resources. For example, steeply sloping areas may make roadway construction too costly, and soils may have insufficient bearing capacity for buildings. Likewise, natural resources are affected by intensity of development. Effects may include increased surface drainage, soil erosion, or air and water pollution.

#### **Climate**

Pennington Gap's climate is characterized by a moderate, continental climate, with fairly cool winters and warm, moist summers. The winters are short and cold, with occasional moderate spells; the summers are warm, with occasional very hot days. Summer evenings and nights are usually cool and pleasant. The average frost-free season is 165 days. The prevailing winds are westerly (from the west and southwest).

#### **Geological Features**

Pennington Gap is located near the dividing point between the Valley and Ridge physiographic province of Virginia, a region characterized by linear east-west to northeast tending valleys and parallel mountain ridges, and the Cumberland Mountain section of the Appalachian Plateau. The Cumberland Mountain section is distinguished by its relief and altitude and is higher than the Cumberland Plateau farther to the west. Stone Mountain is underlain by sandstone that has resisted weather. In contrast, much of the intermountain area is underlain by shale and limestone, both of which are less resistant to weathering than sandstone.

#### **Natural Features**

Pennington Gap is located in a valley formed by Poor Valley Ridge and Stone Mountain at the north and a series of smaller ridges to the south. Most surrounding topography is extreme, with elevations ranging between 1,300 and 1,600 feet above sea level. The median elevation is 1,400 feet.

Air pollution is presently not a significant problem in Pennington Gap. There are no major facilities

located within the Town that adversely influence air quality.

### **Hydrological Features**

Pennington Gap is located in the North Fork Powell River watershed. A smaller drainage basin present in the town is Cane Creek, originating above Ben Hur and flowing in a west-to-east direction through the southern portion of the town. Water that flows from the town’s rooftops, streets, paved and open areas eventually reaches these systems.

Floodplains are normally dry land areas, adjacent to a body of water, that are subject to flooding. The extent of Pennington Gap’s floodplains has been determined by the National Flood Insurance Program and the Federal Emergency Management Agency. The NFIP offers property owners federally subsidized flood insurance. Flood insurance is required before obtaining federally related financial assistance from just about any federal agency and/or program.

### **POPULATION CHARACTERISTICS**

A summary of the Town’s population is shown in **Figure 1**.

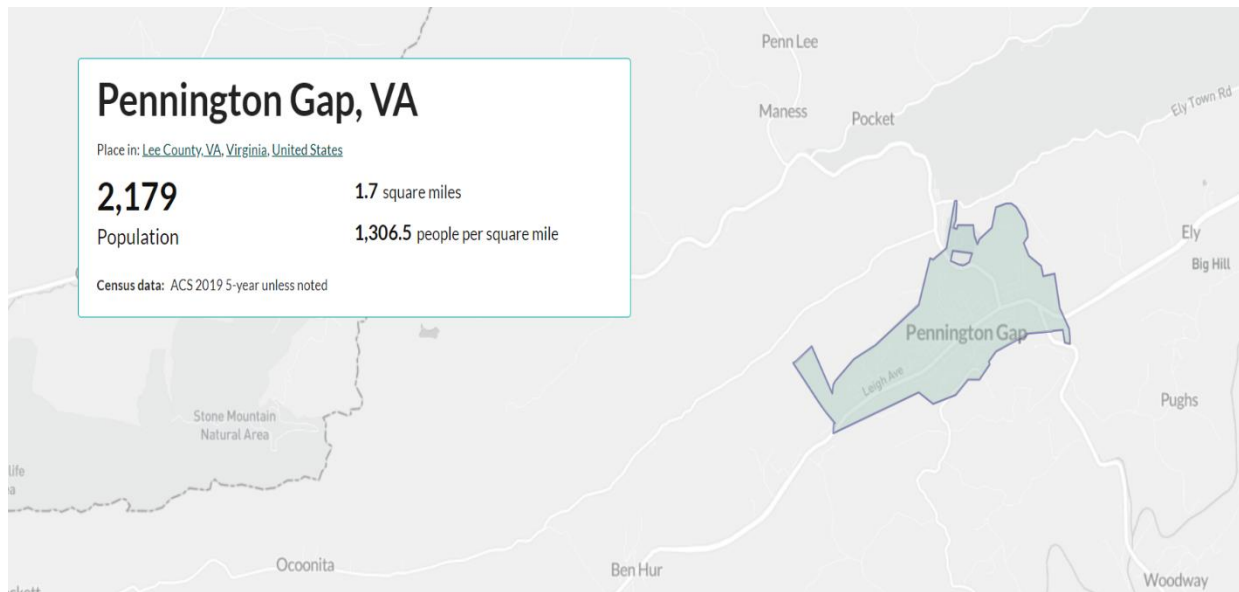

*Fig. 1 (U.S. Census Bureau (2019). American Community Survey 5-year estimates. Retrieved from Census Reporter Profile page for Pennington Gap, VA)*



**Figure 2** outlines the age group and racial distribution of the population of the Town of Pennington Gap.

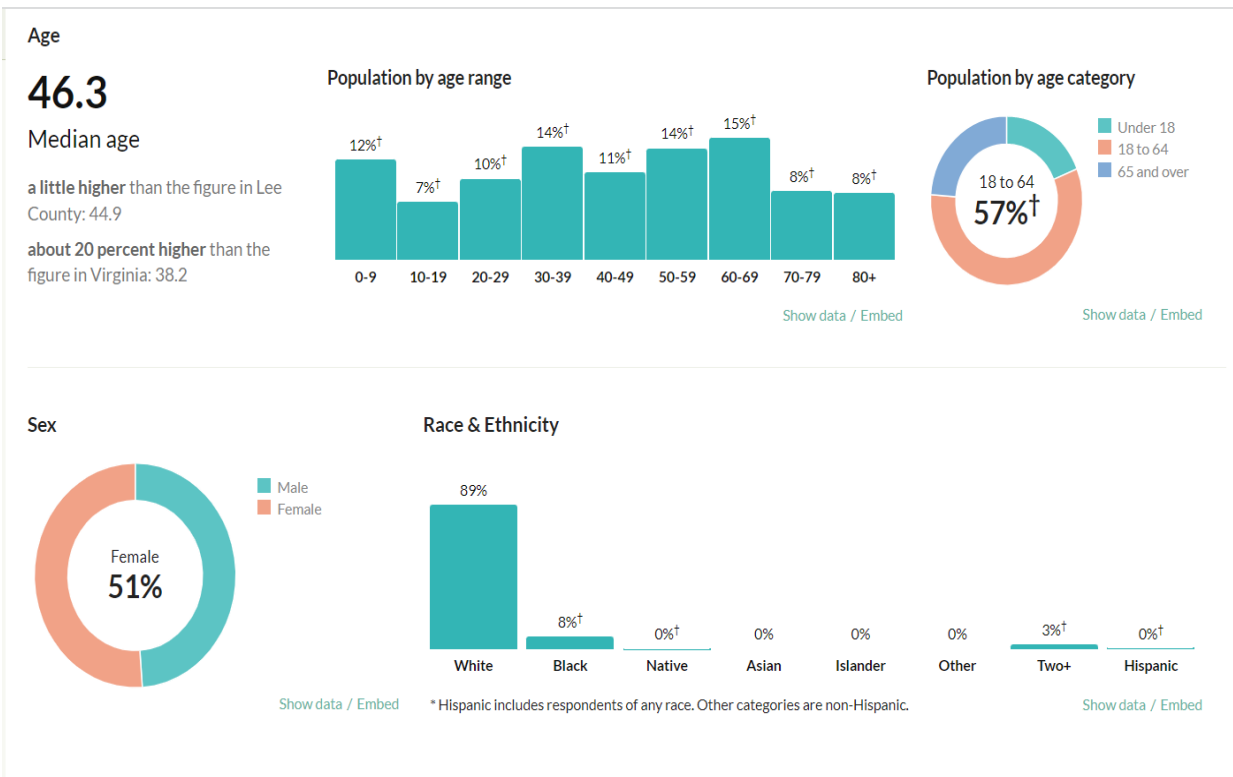

Fig. 2 (U.S. Census Bureau (2019). American Community Survey 5-year estimates. Retrieved from Census Reporter Profile page for Pennington Gap, VA)

## ECONOMIC CHARACTERISTICS

**Figure 3** provides an overview of income, poverty rate, and transportation to work for the Town.

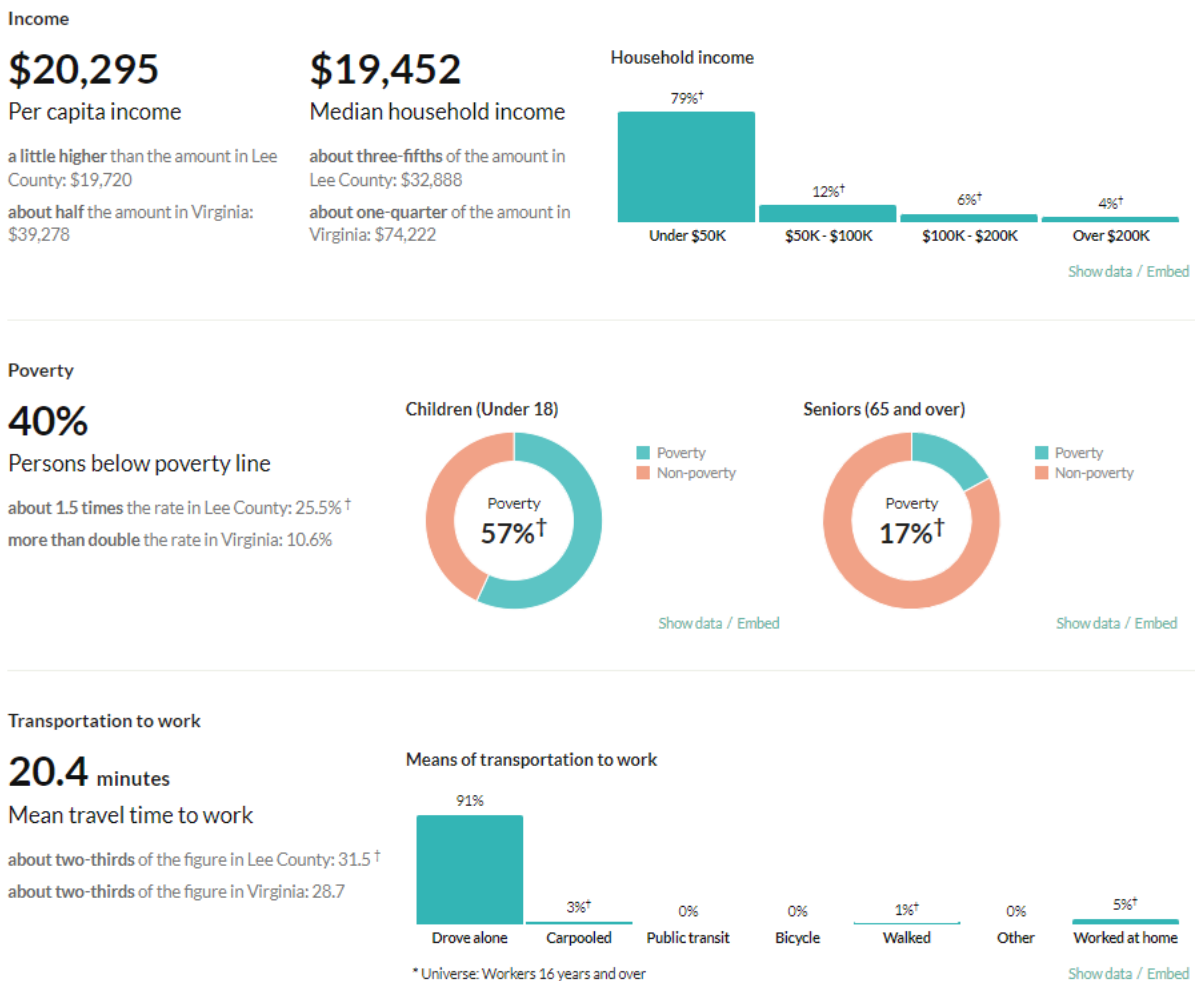

Fig. 3 (U.S. Census Bureau (2019). American Community Survey 5-year estimates. Retrieved from Census Reporter Profile page for Pennington Gap, VA)

## FAMILY CHARACTERISTICS

**Figure 4** provides an overview of family statistics in Pennington Gap.

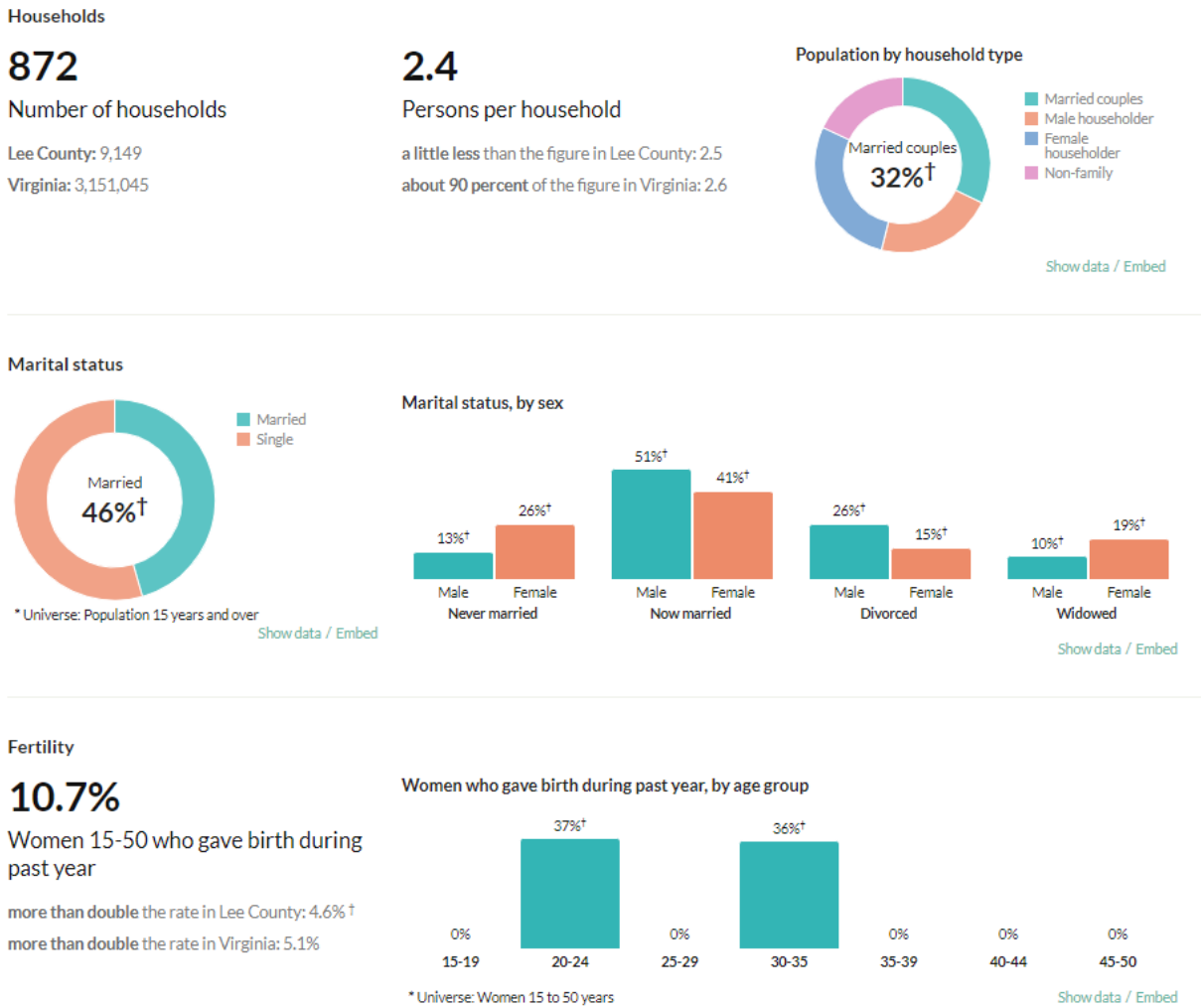
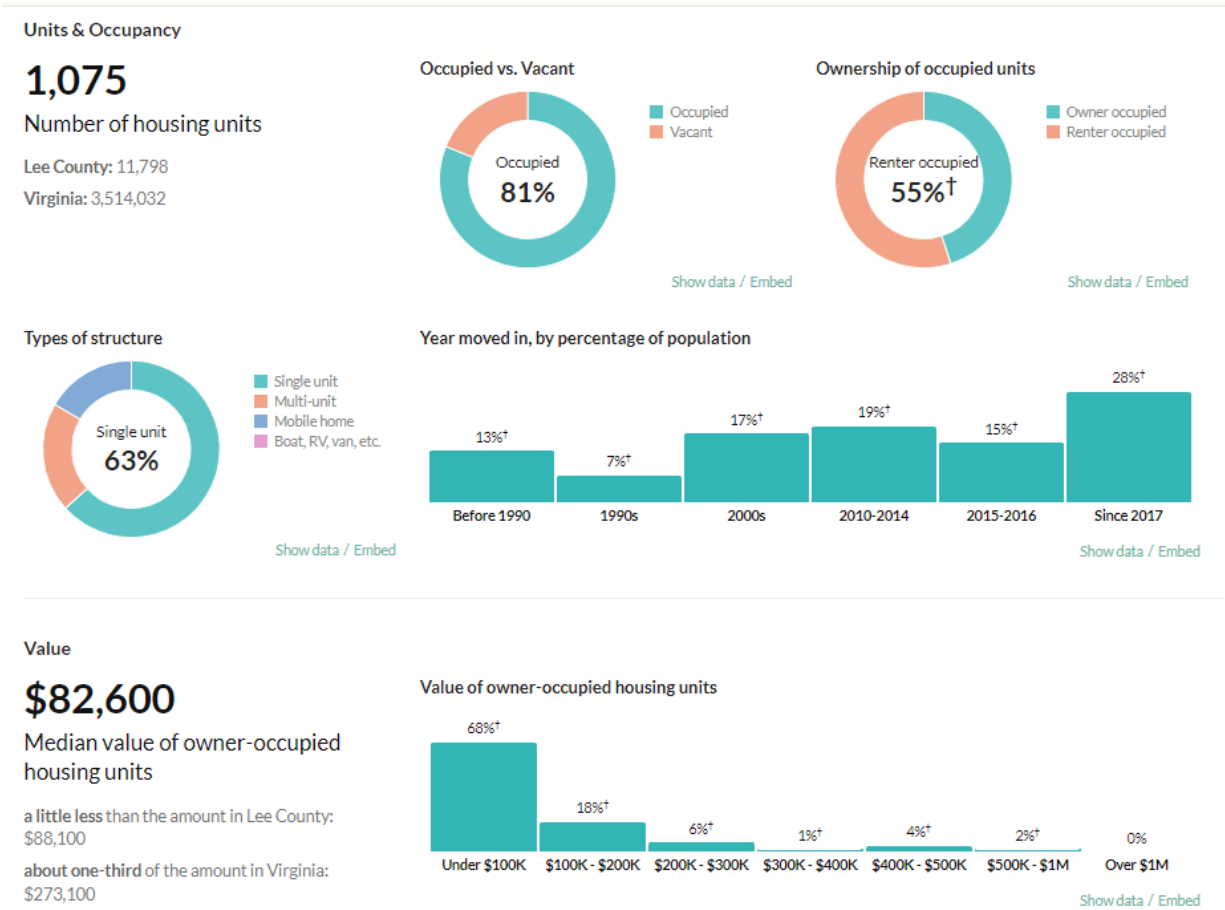

Fig. 4 (U.S. Census Bureau (2019). American Community Survey 5-year estimates. Retrieved from Census Reporter Profile page for Pennington Gap, VA)

## HOUSING CHARACTERISTICS

**Figure 5** presents information about housing statistics in Pennington Gap.



*Fig. 5 (U.S. Census Bureau (2019). American Community Survey 5-year estimates. Retrieved from Census Reporter Profile page for Pennington Gap, VA)*

**Figure 6** gives an overview on geographical mobility and population migration of the Town.

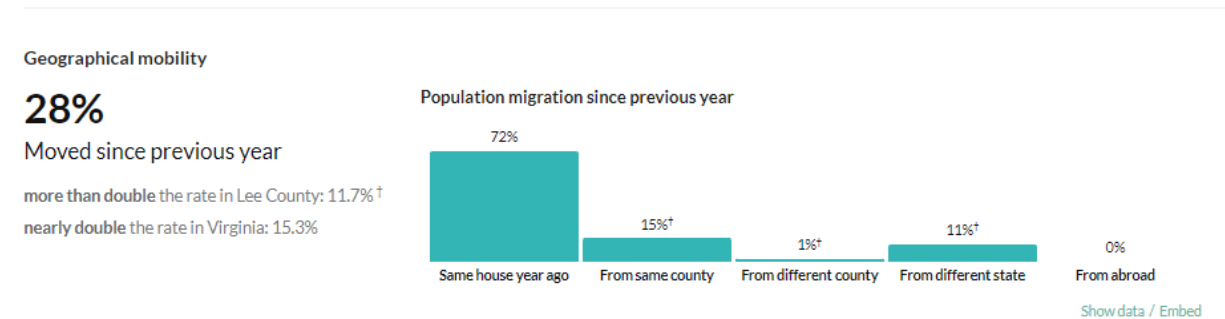

*Fig. 6 (U.S. Census Bureau (2019). American Community Survey 5-year estimates. Retrieved from Census Reporter Profile page for Pennington Gap, VA)*

## SOCIAL CHARACTERISTICS

**Figure 7** outlines educational attainment for the citizens of the Town of Pennington Gap.

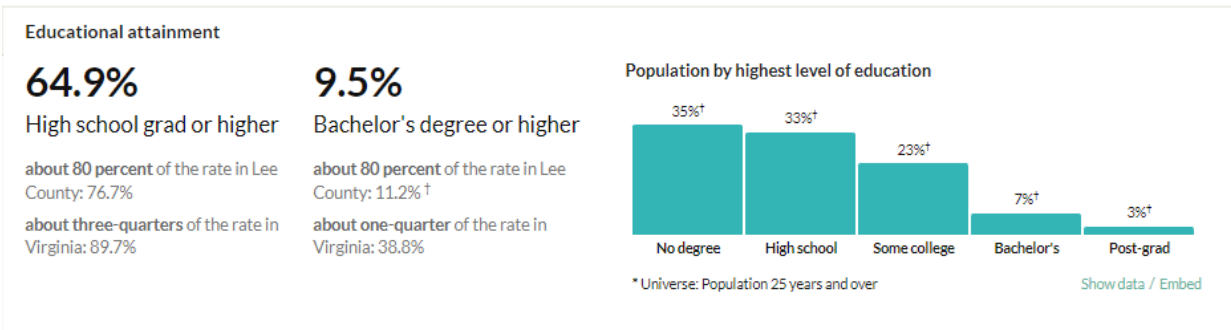

Fig. 7 (U.S. Census Bureau (2019). American Community Survey 5-year estimates. Retrieved from Census Reporter Profile page for Pennington Gap, VA)

A summary of the Town's language statistics and foreign-born population is shown in **Figure 8**.



Fig. 8 (U.S. Census Bureau (2019). American Community Survey 5-year estimates. Retrieved from Census Reporter Profile page for Pennington Gap, VA)

**Figure 9** shows the number of citizens who are veterans in Pennington Gap and their wartime service.

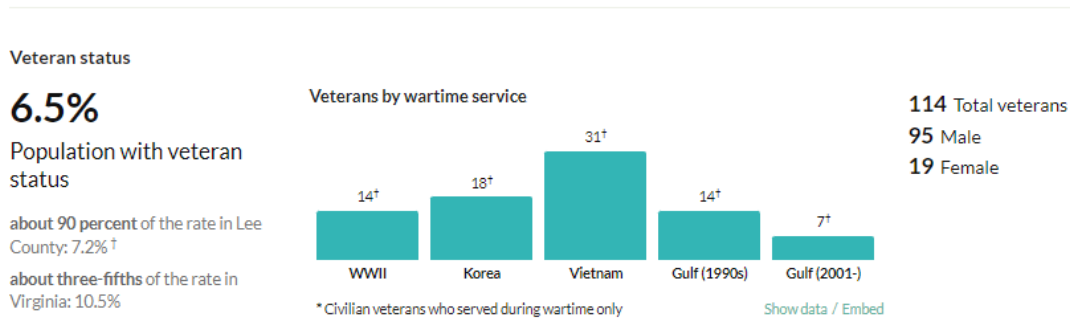

Fig. 9 (U.S. Census Bureau (2019). American Community Survey 5-year estimates. Retrieved from Census Reporter Profile page for Pennington Gap, VA)

## SECTION II - GOALS AND OBJECTIVES

The long-range goals and related short-range objectives presented below serve as the centerpiece for this planning document. Such goals and objectives build upon opportunities and problems identified through analysis of background materials and provide guidance for the adoption of specific policies to implement plan recommendations.

### Environmental Goals and Objectives

#### **Goal:**

Enhance the natural setting of the Town; promote a greater awareness of the natural beauty and positive attributes of the area.

#### **Objectives:**

1. Actively promote appreciation and use of scenic and surrounding areas in the town through development of passive recreation opportunities.
2. Promote environmentally sound and aesthetically pleasing development through judicious review of proposed site and building plans.
3. Promote inclusion of "green" areas in development plans in conjunction with commercial development.
4. Promote inclusion of the installation of signage welcoming visitors to the Town and that promote the character and history of the Town.

5. Encourage and support clean-up efforts of area streams and rivers, including educating residents on the need for removal of straight pipe waste disposal. This could include taking steps necessary with the Virginia Department of Health and other local and state agencies to implement mandatory hook-up to the Town's wastewater system where no other approved alternative exists.

### **Transportation Goals and Objectives**

#### **Goal:**

Promote solutions to relieve current traffic problems and support specific land use objectives as outlined in the Virginia Department of Transportation 2020 Transportation Plan.

#### **Objectives:**

1. Coordinate ingress-egress of all development plans with future highway improvements.
2. Work closely with VDOT officials in planning new routes and making improvements to existing routes that will alleviate traffic congestion and vehicular conflicts in coordination with future transportation planning.
3. Provide new access roads into appropriately zoned areas to stimulate planned potential residential and commercial development.

### **Housing Goals and Objectives**

#### **Goal:**

Provide opportunities to increase the supply, quality and affordability of housing for residents.

#### **Objectives:**

1. Encourage the construction of new middle class single-family and multi-family housing in designated areas suitable for such development through the provision of utilities and roads.
2. Examine potential areas for boundary adjustments to facilitate future housing development.
3. Develop a set of specific design standards to be applied in the future development of subdivisions.
4. Encourage the general maintenance and upkeep of existing residences through the enforcement of local housing code, as well as the ordinance on abandoned vehicles and yard maintenance.
5. Provide incentives for general neighborhood improvements and individual property

rehabilitation by targeting comprehensive public improvement programs in neighborhoods of greatest need.

6. Adopt neighborhood revitalization programs for blighted areas.

### **Public Facilities Goals and Objectives**

#### **Goal:**

Expand and develop existing and future public facilities to improve quality of life for citizens and visitors of the Town of Pennington Gap while focusing on the Town's heritage and history.

#### **Objectives:**

1. Continue to develop recreational/cultural facilities for residents and visitors of the Town, such as the recent redevelopment of the Lee Theatre and the Pennington Gap Community Center.
2. Study the potential for a Downtown Main Street Coordinator position to help develop the downtown area with emphasis on the rich history of the Town.
3. Determine the viability of renovation or replacement of the existing fire hall and other public facilities as needed.

#### **Goal:**

Provide facilities and events commensurate with the needs of the present and future population.

#### **Objectives:**

1. Begin a campaign to create a "brand" for the Town of Pennington Gap that can be used to market the area for tourism.
2. Change or find a new identity or image for the Town to move forward into the next 25 years.

### **Economic Growth Goals and Objectives**

#### **Goal:**

Facilitate economic growth and diversification in and around the Town.

#### **Objectives:**

1. Begin to use the natural heritage and environment as economic development tools. Primary focus should be place on "ecotourism"-type businesses that can capitalize on what Pennington Gap already has (e.g., ATV trails, RV park, ATV safety training area, farmers market).



2. Assess the need for additional lodging/motel facilities in the Town to better capitalize on visitors to the area.
3. Assist and encourage the Lee County Economic Development Authority to focus on Pennington Gap as an area that can be a leader in the development of economic recruitment.

### **Implementation Goals and Objectives**

#### **Goal:**

Make effective use of implementation tools provided to carry out plan goals and objectives.

#### **Objectives:**

1. Continue to review and revise the Comprehensive Plan at least every five years, so it can continue to be a useful guide for future growth and development.
2. Establish a set of procedures that will encourage systematic reference of proposed improvements to standards, goals and objectives set forth by the Comprehensive Plan.
3. Develop and use zoning and subdivision ordinances that establish practical land use regulations, standards for design, and environmental quality.
4. Develop a priority list of proposed major capital improvements and recommended program for accomplishment based on a fiscal forecast of the Town.

### **Land Use Goals and Objectives**

#### **Goal:**

Encourage harmonious and wise use of land through future development decisions.

#### **Objectives:**

1. Whenever practical, require aesthetic improvements such as trees, landscaped buffers and underground utilities to provide attractive divisions between conflicting land uses.
2. Study compatible areas within Town boundaries for building sites.
3. Consider the expansion beyond present corporate boundaries into areas most suitable for land development, which will strengthen the Town's tax base.

## **SECTION III - IMPLEMENTATION OF PLAN**

### **Administration of the Plan**

The Pennington Gap Comprehensive Plan document represents the continuation of formal, organized planning for the Town and immediate planning area. The Plan should serve as a foundation for addressing local problems and recognizing future needs and demands of growth. The Plan offers an opportunity for Town leaders to apply appropriate controls and direct both public and private investments in a logical manner to achieve short-range objectives and long range goals.

The following sections address legal status, policy and administration of the Pennington Gap Comprehensive Plan required to promote an efficient application of plan provisions.

### **Legal Status of the Plan**

The following excerpts are taken from Title 15.2, Chapter 22 Code of Virginia, 1950 and support the legal foundation for the comprehensive plan.

15.2-2232 - Whenever the local commission shall have recommended a comprehensive plan or part thereof for the municipality and such plan shall have been approved and adopted by the governing body, it shall control the general or approximate location, character and extent of each feature shown on the plan. Thereafter, unless such feature is already shown on the adopted master plan or part thereof no street, park or other public area, public building or public structure, public utility facility or public service corporation facility other than railroad facility, whether publicly or privately owned, shall be constructed, established or authorized, unless and until the general location or approximate location, character, and extent thereof has been submitted to and approved by the local planning commission as being substantially in accord with the adopted comprehensive plan or part thereof. In connection with any such determination the commission may, and at the direction of the governing body shall, hold a public hearing after notice as required.

### **Plan Adoption**

The following provisions taken from Title 15.2 Chapter 22, outline the general procedures to be followed by the Town of Pennington Gap in adopting the Comprehensive Plan.

15.2-2225 - Notice and Hearing on Plan. Recommendation by local commission to governing body. Prior to the recommendation of a comprehensive plan or any part thereof, the local commission shall give notice and hold a public hearing on the plan. After such public hearing has been held the commission may approve, amend and approve, or disapprove the plan. Upon the approval of the plan, the commission shall by resolution recommend the plan to the governing body.

15.2-2226 - Adoption or Disapproval of Plan by Governing Body. After certification of the plan or part thereof, the governing body after a public hearing with notice as required shall proceed to a

consideration of the plan or part thereof and shall approve and adopt, amend and adopt, or disapprove the same within ninety days after date of adoption of such resolution.

15.2-2227 - Return of the Plan to Commission; Resubmission. If such governing body disapproves the plan, then it shall be returned to the local commission for its reconsideration, with a written statement of the reasons for its disapproval.

The commission shall have sixty days in which to reconsider the plan and resubmit it with any changes to the governing body.

15.2-2228 - Adoption of Parts of Plan. As the work of preparing the comprehensive plan progresses, the local commission may, from time to time, recommend, and the governing body approve and adopt, parts thereof, and such part shall cover one or more major sections or divisions of the municipality or one or more functional matters.

### **Maintenance of the Plan**

15.2-2229 - Amendments. After the adoption of a comprehensive plan, all amendments to it shall be recommended, and approved and adopted, respectively. If the governing body desires an amendment it may direct the local commission to prepare an amendment and submit it to public hearing within sixty days after formal written request by the governing body.

15.2-2230 - Plan to be Reviewed At Least Once Every Five Years. At least once every five years, the comprehensive plan shall be reviewed by the local commission to determine whether it is advisable to amend the plan.

Significant new developments, i.e. state highway proposals; location of new industry, shopping center, or residential subdivision; expansion of major public/private uses, etc., should trigger a re-evaluation of the adopted comprehensive plan. Review and appropriate revisions to the plan ensuring consistency with major proposals should be made to maintain it in a current condition. Changes in the plan should only be made in the best interest of established goals and objectives. Development proposals, which are contrary to the plan, require serious consideration within the contact of the plan's provisions. The end result of unwarranted plan revision would be to leave the Town without any enforceable plan.

### **Plan Implementation**

Private property development and public improvement efforts can be coordinated with the plan through the use of applicable regulatory measures - zoning ordinance, subdivision regulations, building and housing codes. An adopted Capital Improvement Program also provides a mechanism for the local governing body to schedule public improvements in accordance with the plan over both a five-year period and on an annual basis.

15.2-2239 - Local Commissions to Prepare and Submit Annually Capital Improvement Programs to Governing Body or Official Charged with Preparation of Budget. A local commission may, and at the direction of the governing body shall, prepare and revise annually a capital improvement program based on the comprehensive plan of the municipality for a period not to exceed the

ensuring five years. The commission shall submit the same annually to the governing body, or to the chief administrative officer or other official charged with preparation of the budget for the municipality, at such time as it or he shall direct.

Such capital improvement program shall include the commission's recommendations, and estimates of cost of such facilities and the means of financing them, to be undertaken in the ensuing fiscal year and in a period not to exceed the next four years, as the basis of the capital budget for municipality. In the preparation of its capital budget recommendations, the commission shall consult with the chief administrative officer or other executive head of the government of the municipality, the heads of departments and interested citizens and organizations and shall hold such public hearings as necessary unless otherwise required.

15.2-2240 - Municipalities to Adopt Ordinances Regulating Subdivision and Development of Land. The governing body of any locality shall adopt an ordinance to assure the orderly subdivision of land and its development.

15.2-2280 - Zoning Ordinances Generally. Any locality may, by ordinance, classify the territory under its jurisdiction or any substantial portion thereof into districts of such number, shape and size as it may deem best suited to carry out the purposes of this article, and in each district it may regulate, restrict, permit, prohibit, and determine the following:

The use of land, buildings, structures and other premises for agricultural, business, industrial, residential, flood plain and other specific uses;

The size, height, area, bulk, location, erection, construction, reconstruction, alteration, repair, maintenance, razing or removal of structures;

The areas and dimensions of land, water, and air space to be occupied by buildings, structures and uses, and of courts, yards, and other open spaces to be left unoccupied by uses, structures, including variations in the size of lots based on whether a public or community water supply or sewer system is available and used;

The excavation or mining of soil or other natural resources. For the purpose of zoning, the governing body of a municipality shall have jurisdiction over the incorporated area of the municipality.

The Zoning Ordinance and Subdivision Regulations for the Town of Pennington Gap accompany this plan document. Legal enforcement is explained within the text of these regulations. The comprehensive plan must be used as the reference by which zoning requests, development proposals and the zoning of subdivision regulations are reviewed for approval or disapproval. Zoning and subdivision regulations are the tools intended to accomplish the plan's objectives.

### **Regional Review and Coordination**

Local town planning requires coordination with other adjacent jurisdictions: Lee County, regional, state and federal development proposals and plans. Without coordination among these jurisdictions, the danger of planning efforts being duplicated or conflicting will result in ineffective

programs and unnecessarily high development costs. The LENOWISCO Planning District Commission is the most appropriate agency to provide regional coordination and review of related plan.

### **Level of Professional Planning Assistance**

Planning assistance is presently provided to the Town of Pennington Gap by the staff of LENOWISCO and through contracted services of private planning consultants for special projects. Communities with less than 10,000 in population typically do not require an in-house planning staff to administer daily planning functions. Special needs of the local planning commission which may warrant additional planning assistance from LENOWISCO and/or a planning consultant in order to implement the adopted comprehensive plan may include the following:

1. Maintenance of the Comprehensive Plan - Unforeseen changes in development trends, population growth or effects of economic changes resulting from new industrial or commercial development, annexation or consolidation; all would have a major impact on long range community planning which would need to be reflected in the Comprehensive Plan.
2. Expansion of Major Elements of the Comprehensive Plan - The need for neighborhood studies, a plan for the central business district, housing need analysis, economic development studies may evolve from the recommendations contained in the Comprehensive Plan. Such special studies should be used to expand on plan generalities and be treated as amendments to the adopted Comprehensive Plan.
3. Review and Administration of Housing, Building, Zoning and Subdivision regulations and Development proposals which affect provisions of the Comprehensive Plan.
4. Assist in determining the most appropriate state and federal assistance programs through which Pennington Gap may participate to aid in implementing proposed community improvements.
5. Promote local citizen involvement in planning by conducting public education programs on the Comprehensive Plan and related planning process.

### **Public Education and Community Involvement**

The Town of Pennington Gap should continue to expand a public awareness program to inform local citizenry, including local commission members, on local planning efforts and issues. The intent of such program is to solicit citizen participation in making planning decisions and to promote public support for existing and future community improvement efforts. A classroom-type program could be offered to adult and student groups through the Lee County Career and Technical Center or through a series of lectures of citizen advisory groups, civic organizations and other interested individuals. Local planning commission members should be encouraged to attend Planning Commissioner Institute training sessions offered periodically throughout the year by the Virginia Department of Housing and Community Development (VDHCD). Educational materials are also available from VDHCD, which should be distributed to local planning commissioners.

*Additional measures, which can be promoted by the Town to increase public awareness of local planning, include the following:*

1. Development of a brochure or graphic foldout depicting the Comprehensive Land Use and Transportation Plan on one side and an executive summary of major plan elements on the reverse.
2. Exhibits and displays of important Plan elements placed in Town Hall, local bank lobbies, public schools, etc.
3. Newspaper coverage of the comprehensive plan adoption process, highlights of land use and special zoning issues, in-depth series of articles on land use problems and opportunities in and around Pennington Gap, series of interviews with individuals in responsible positions in local and regional governmental agencies, business and industry who influence future land use decisions.

# Appendix A: Application Form for Grant and Loan Requests for All Categories

Virginia Department of Conservation and Recreation  
Virginia Community Flood Preparedness Fund Grant Program

**Name of Local Government:** Town of Pennington Gap

**Category Being Applied for (check one):**

**Capacity Building/Planning**

**Project**

**Study**

**NFIP/DCR Community Identification Number (CID):** 510087#

**Name of Authorized Official and Title:** Keith Harless, Town Manager

**Signature of Authorized Official:** \_\_\_\_\_

**Mailing Address (1):** 528 Industrial Road

**Mailing Address (2):** \_\_\_\_\_

**City:** Pennington Gap **State:** VA **Zip:** 24277

**Telephone Number:** (276) 546-1177 **Cell Phone Number:** (276)393-0048

**Email Address:** keith.harless@townofpenningtongapva.gov

**Contact and Title (If different from authorized official):** Tammy Jo Franklin, Director of Parks and Recreation

**Mailing Address (1): 528 Industrial Road**

**Mailing Address (2):** \_\_\_\_\_

**City:** Pennington Gap **State:** VA **Zip:** 24277

**Telephone Number:** (\_\_\_\_) \_\_\_\_\_ **Cell Phone Number:** (276)393-0335

**Email Address:** tammy.jo@townofpenningtongapva.gov

Is the proposal in this application intended to benefit a low-income geographic area as defined in the Part 1 Definitions? Yes **X** No \_\_\_\_\_

**Categories (select applicable activities that will be included in the project and used for scoring criterion):**

**Capacity Building and Planning Grants**

- Floodplain Staff Capacity.
- Resilience Plan Development
  - Revisions to existing resilience plans and modifications to existing comprehensive and hazard mitigation plans.
  - Resource assessments, planning, strategies, and development.
    - Policy management and/or development.
    - Stakeholder engagement and strategies.

Other: \_\_\_\_\_

**Study Grants (Check All that Apply)**

Studies to aid in updating floodplain ordinances to maintain compliance with the NFIP, or to incorporate higher standards that may reduce the risk of flood damage. This must include establishing processes for implementing the ordinance, including but not limited to,



permitting, record retention, violations, and variances. This may include revising a floodplain ordinance when the community is getting new Flood Insurance Rate Maps (FIRMs), updating a floodplain ordinance to include floodplain setbacks, freeboard, or other higher standards, RiskMAP public noticing requirements, or correcting issues identified in a Corrective Action Plan.

Revising other land use ordinances to incorporate flood protection and mitigation goals, standards, and practices.

Conducting hydrologic and hydraulic (H&H) studies of floodplains. *Changes to the base flood, as demonstrated by the H&H must be submitted to FEMA within 6 months of the data becoming available.*

Studies and Data Collection of Statewide and Regional Significance.

Revisions to existing resilience plans and modifications to existing comprehensive and hazard.

Other relevant flood prevention and protection project or study.

**Project Grants and Loans (Check All that Apply – Hybrid Solutions will include items from both the “Nature-Based” and “Other” categories)**

**Nature-based solutions**

Acquisition of property (or interests therein) and/or structures for purposes of allowing floodwater inundation, strategic retreat of existing land uses from areas vulnerable to flooding; the conservation or enhancement of natural flood resilience resources; or acquisition of structures, provided the acquired property will be protected in perpetuity from further development, and where the flood mitigation benefits will be achieved as a part of the same project as the property acquisition.

Wetland restoration.

Floodplain restoration.

Construction of swales and settling ponds.

Living shorelines and vegetated buffers.

Permanent conservation of undeveloped lands identified as having flood resilience value by *ConserveVirginia* Floodplain and Flooding Resilience layer or a similar data driven analytic tool, or the acquisition of developed land for future conservation.

Dam removal.

Stream bank restoration or stabilization.

Restoration of floodplains to natural and beneficial function.

## Other Projects

Structural floodwalls, levees, berms, flood gates, structural conveyances.

Storm water system upgrades.

Medium and large-scale Low Impact Development (LID) in urban areas.

Developing flood warning and response systems, which may include gauge installation, to notify residents of potential emergency flooding events.

Dam restoration.

Beneficial reuse of dredge materials for flood mitigation purposes

Removal or relocation of structures from flood-prone areas where the land will not be returned to open space.

Acquisition of property (or interests therein) and/or structures for purposes of allowing floodwater inundation, strategic retreat of existing land uses from areas vulnerable to flooding; the conservation or enhancement of natural flood resilience resources; or acquisition of structures, provided the acquired property will be protected in perpetuity from further development, and where the flood mitigation benefits will **not be** achieved as a part of the same project as the property acquisition.

Other project identified in a DCR-approved Resilience Plan.

**Location of Project or Activity (Include Maps):** Lee County VA, please see attached maps

**NFIP Community Identification Number (CID#) :** 510087#

**Is Project Located in an NFIP Participating Community?**  Yes  No

**Is Project Located in a Special Flood Hazard Area?**  Yes  No

**Total Cost of Project:** \$50,000

**Total Amount Requested:** \$50,000

**For projects, planning, capacity building, and studies in low-income geographic areas: Are you requesting that match be waived?**  Yes  No

## **A. Scope of Work Narrative**

### **1. Locality Capacity-building to Prepare for Resilience Planning**

The Town of Pennington Gap is submitting this grant application to the Virginia Community Flood Preparedness Fund (CFPF) in the Capacity Building and Planning category. The town seeks award from this category to fund two town employees in becoming Certified Floodplain Managers (CFMs), to hire a Consultant who will conduct a scoping analysis of floodplain hydrology and mitigation priority needs in Pennington Gap that includes a flood mitigation project opportunity list in preparation for future flood resilience planning efforts. Project opportunities will align with and consider LENOWISCO Planning District Commission (PDC) planning documents such as the Comprehensive Plan and Hazard Mitigation Plan, as well as the Town's Greenway Survey and Lee County's Comprehensive Plan, to ensure cohesive alignment with current and future regional flood resilience objectives.

### **Town Background & Needs Assessment**

Officially incorporated in 1891, the Town of Pennington Gap is located in far southwest Virginia and is the most populous town in Lee County, home to approximately 1,600 residents. The Town of Jonesville, the county seat of Lee County, is located six miles west of Pennington Gap, while the Town of Big Stone Gap, in adjacent Wise County, is 16 miles to the east. U.S. Highways 58 and 421 and numerous secondary roads serve the Town.

Pennington Gap's history of mining and logging has left it uniquely vulnerable to natural disasters, including repeated flooding, especially along the North Fork of Wallen Creek along their recreational areas and near their town hall and police headquarters. Lee County has had 14 federally-declared disasters due to precipitation since 1977 in addition to numerous other flood events that did not qualify as federally-declared disasters. Flood waters are well-known to be unsafe, and the additional pollution stemming from extractive activities make it a priority to contain any floodwaters threatening buildings and residents. As a low-income community affected by periodic flooding, Pennington Gap provides an ideal community for investing in flood mitigation, including nature-based practices.

The LENOWISCO PDC conducted a hazard mitigation survey in 2021 and noted several development constraints, including steep slopes, poor soil conditions, flood-prone areas, mineral land under development, land subject to subsidence from underground mining, and the presence of National Forest and other public lands. Of 278,910 acres in Lee County, about 82% have slopes over 20% and another 6.4% between 10-20%. Due to these restrictive factors, much of the historical development in Lee County is concentrated along main transportation corridors (Highways 23 and 58) and within the floodplain, as the roadways tend to follow the paths of rivers and creeks. Land along plateaus or ridge tops may be more suitable for development but does not have adequate transportation or utility access.

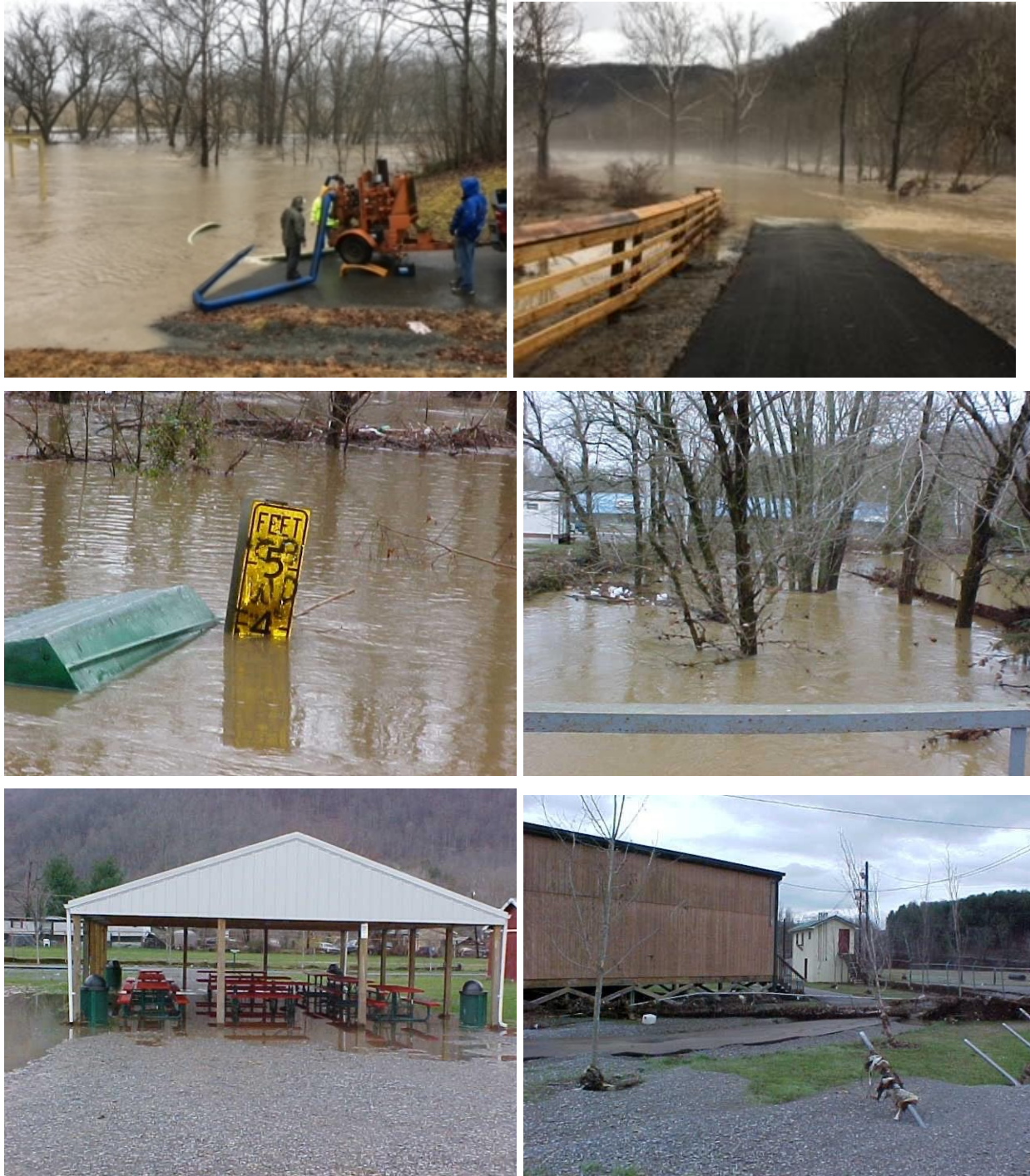

*Fig. 1-6: Previous flood events in Pennington Gap.*

This CFPF grant will allow Pennington Gap to hire a consultant who will conduct a detailed assessment of the Town's floodplains and wetlands. The consultant will work with the Town and local stakeholders to compile strategies for flood mitigation that protects vital Town buildings while allowing residents to continue to utilize the recreational area. As shown in the diagrams



below, a large portion of this area is either a regulatory floodplain or is categorized as being at risk of 100 year floods.

The site-specific survey and flood-mitigation opportunities compiled through this CFPF award will help ensure the protection of the Town Hall and police headquarters, both of which are vital community resources, especially during flood events. Additionally, there are plans to potentially turn the Town Hall into a disaster resiliency hub for community members during hazardous weather events such as flash floods – further highlighting the need to make sure that the flood risks to Town assets are as minimized as possible.

This CFPF award will allow the Town to gain a more detailed flood mitigation opportunity project list while also developing a strategy to implement some of the recommendations made in the LENOWISCO PDC report. These flood reduction efforts will not only benefit the local employees and emergency responders who work in the area, but also residents who rely on Town services, community members who would require a shelter during disasters, and groups like schoolchildren, senior citizens, and local recreational clubs who regularly use the greenspace.

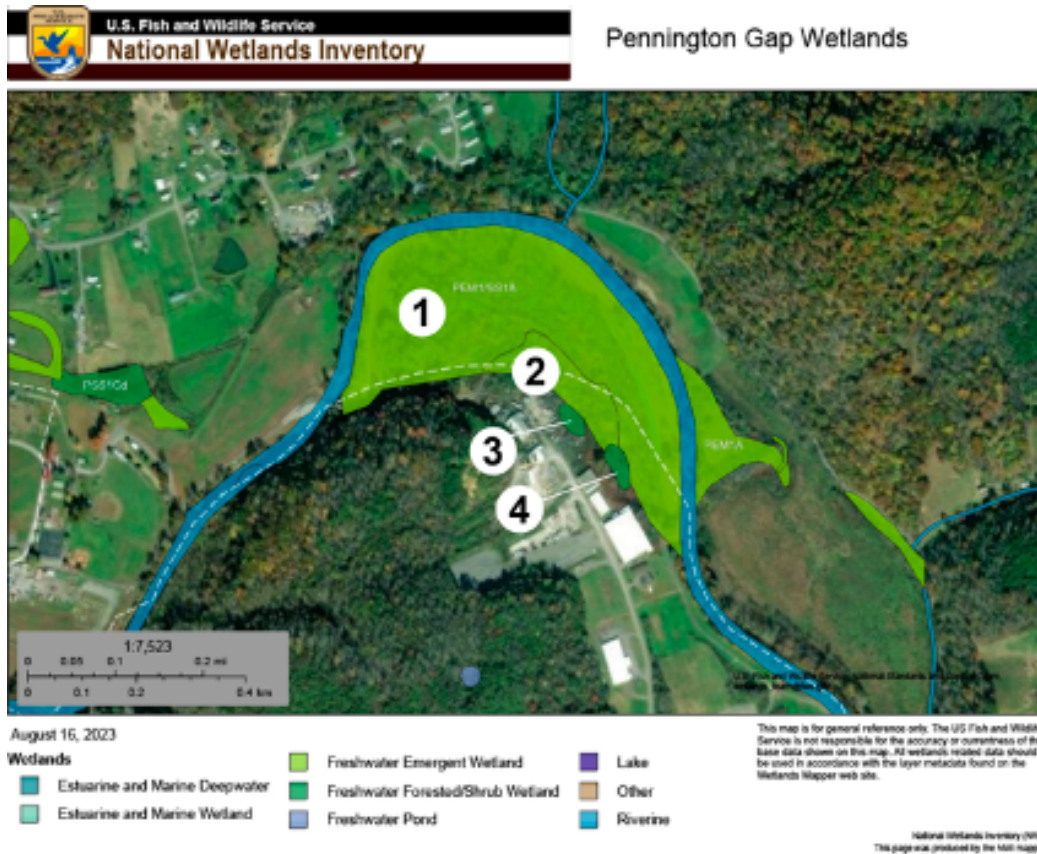

*Figure 7. Map showing the regulatory floodway in red and the 100-year floodplain in blue, courtesy of the Virginia Flood Risk Information System.*

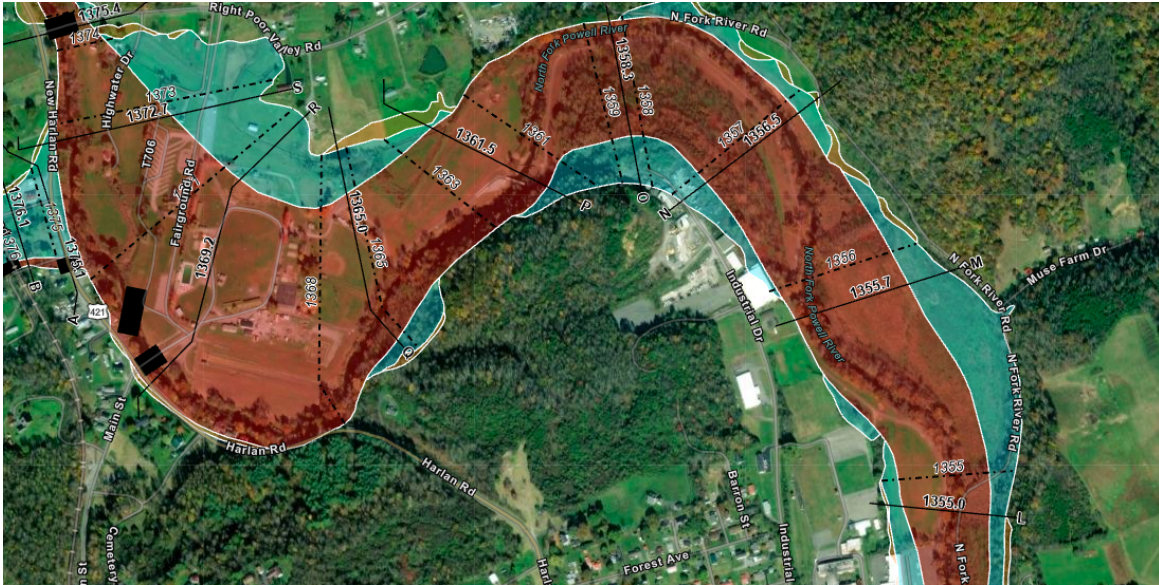

Figure 8. Map of wetland areas from the National Wetlands inventory. Numbers added to indicate individual wetland habitats.

State	County	Declaration Date	Disaster Number	Incident Subcategory	Information
Virginia	Lee County	09/11/2018	3403	Hurricane	<a href="#">i</a>
		10/29/2012	3359	Hurricane	<a href="#">i</a>
		02/16/2010	1874	Snowstorm	<a href="#">i</a>
		09/12/2005	3240	Hurricane	<a href="#">i</a>
		06/15/2004	1525	Severe Storm	<a href="#">i</a>
		03/27/2003	1458	Severe Storm	<a href="#">i</a>
		04/02/2002	1406	Severe Storm	<a href="#">i</a>
		07/12/2001	1386	Severe Storm	<a href="#">i</a>
		02/28/2000	1318	Severe Storm	<a href="#">i</a>
		01/13/1996	1086	Snowstorm	<a href="#">i</a>
		03/10/1994	1014	Snowstorm	<a href="#">i</a>
		03/25/1993	3112	Snowstorm	<a href="#">i</a>
		11/12/1977	543	Flood	<a href="#">i</a>
04/07/1977	530	Flood	<a href="#">i</a>		

Figure 9. List of federally-declared disasters in Lee County due to precipitation.

## **2. Goals and Objectives**

As a low-income locality in southwest Virginia with limited capacity and no CFMs on staff, this CFPF award will help provide a necessary baseline from which the Town can build. The goals of this project are to:

1. Allow Pennington Gap to implement the flood mitigation recommendations made in the LENOWISCO PDC Report.
2. Gain a more detailed understanding of the ecology and hydrology of the wetlands and floodplains most adjacent to the Town Hall and police station
3. Prepare for nature-based flood mitigation projects in those areas by developing a Community Flood Preparedness Scoping Plan.
4. Train two local staff to be Certified Floodplain Managers.

All information gathered and project concepts created are intended to better position the Town to apply for and create a successful Resilience Plan in a future CFPF grant round. The CFM certification process and assessment and strategic planning portion will take approximately 9 months to complete.

## **3. Work Plan**

### Pennington Gap Ecology and Hydrology Analysis

The Town of Pennington Gap plans to contract an engineering consultant to conduct the data collection, site assessment, and develop the priority project list for the referenced area. Other Town departments will assist the Consultant by providing all existing Town documents that pertain to the floodplains and wetlands area and future planning. Town staff will also engage other departments in discussion and input during the project list development process. Estimates for the scope of work and cost come from consultation with Hirschman Water and Environment, LLC; a contract has not yet been finalized and a final consultant decision will be made after notification of a successful CFPF grant award.

#### Task 1. Gather Existing Data

Research and gather all existing data sources, including FEMA detailed study, wetland delineations as per the Pennington Gap Greenway Survey, USGS stream gage data, physical surveys, property ownership and easements, and other data available through the Town, state and federal agencies, and Vaughn & Melton, the engineering firm that conducted the Town's Greenway Survey.

#### Task 2. Jurisdictional Area Preliminary Survey

To the extent needed, conduct a field identification of potential jurisdictional areas for the purposes of creating project base maps. It is noted that the National Wetland Inventory identifies significant wetlands at the site, but the Web Soil Survey indicates well-drained and moderately

well-drained non-hydric alluvial soils, so there is some disconnect from available information. This step will be preliminary to completing a Preliminary Jurisdictional Determination report and any subsequent permitting documents, but those items are not included in the existing study.

### *Task 3. Develop Site & Watershed Concepts*

Based on the information collected, the Consultant will work with the Town to develop five to seven preliminary concepts for watershed and river corridor storage and flood abatement focusing on nature-based solutions and targeting the most vulnerable flooding areas in terms of communities, infrastructure, and natural resources (including the Town Hall). These concepts could also include review of local development codes to identify obstacles and opportunities for addressing flood resilience. The concepts can be ranked and prioritized based on criteria that are part of the CFPPF program: equitable, cost effectiveness, and uses natural solutions.

### *Task 4. Community Engagement*

Community engagement will likely entail two community meetings. The first will be scheduled near the beginning of the project to solicit ideas about strategies, possible project locations, and any community “show stoppers” in terms of types of solutions (e.g., don’t take any agriculture fields out of production) to solicit a wide range of input to inform concept development. The second meeting could be after development of preliminary concepts from Task 3 to get feedback and refinements. In addition, a webpage created by the Town or partners at Appalachian Voices could be used to house project information along with a feedback mechanism, such as an online community survey.

### *Task 5. Community Flood Preparedness Scoping Plan*

The results of Tasks 1 through 4 will be pulled together as a Community Preparedness Scoping Plan for Pennington Gap’s Comprehensive Plan to guide future implementation. The priority project list will include maps, graphics, and a narrative. This will not include project permitting, detailed FEMA computations (e.g., letters of map amendment), project design, and other technical material needed for future implementation.

### *Staff CFM Training*

In order to increase local capacity, Pennington Gap will use part of the CFPPF funds to allow two employees to become a Certified Floodplain Manager and join The Association of State Floodplain Management (ASFPM). Once certification is achieved, they will complete continuing education coursework to maintain their certification while employed by Pennington Gap.

### *Qualifications of Project Leaders*

Keith Harless is the Town Manager for Pennington Gap. He has served in this role for almost eight years and has overseen a myriad of projects in the town, including a town partnership with Virginia Clean Cities to conduct an extended test drive of an all-electric 2023 Chevrolet Bolt EUV as part of a larger regional project titled "Rural Reimagined: Building an EV Ecosystem



and Green Economy for Transforming Lives in Economically Distressed Appalachia." Harless is also currently leading multiple economic revitalization efforts, such as the restoration of downtown brownfields buildings and the creation of a Center for the Trades technical training facility.

Tammy Jo Franklin is Pennington Gap's Parks and Recreation Director, having stepped into the role in early 2022. She has extensive experience with community engagement and development, having previously worked for the Town of Big Stone Gap and non-profit Mountain Empire Older Citizens, Inc. Franklin leads work involving the town's green spaces and recreational areas and is dedicated to providing safe outdoor recreation opportunities that are conservation-focused and benefit the community in more ways than one.

Emma Kelly is the New Economy Field Coordinator with Appalachian Voices, a regional environmental justice nonprofit with an extensive history of community engagement, environmental conservation, and project administration. She is a trained community organizer who manages community outreach initiatives, facilitates regular community listening sessions and the New Economy Network, and works directly with other environmental justice organizations and coalitions. She has been working with Pennington Gap for almost a year and is familiar with federal, state, and regional development and climate resiliency initiatives.

### ***Deliverables***

The City currently does not have any employees with the ASFPM Certified Floodplain Manager (CFM) certification, while the County only has one such employee. The grant will be used to pay for the ASFPM membership, training, and CFM exam fee for two employees. The knowledge achieved in preparation for the exam and in continuing education courses will increase staff's ability to identify flood risk, mitigate current flooding issues, conserve valuable wetlands, and better utilize existing floodplains. If necessary, the new CFM employed by Pennington Gap can also serve surrounding communities in Lee County in the event that the current county CFM requires assistance.

Success will be measured in the achievement and retainment of CFM certification by two Pennington Gap employees, as well as the creation of a floodplain mitigation and use plan. This plan will provide many benefits to Pennington Gap and its residents, including the following:

- An assessment of the areas along Wallens Creek that are at risk of flooding or may be vulnerable in the future due to proximity to a water body, low elevation, undersized stormwater infrastructure, high water table, etc.
- The identification of any critical facilities such as town government buildings or critical infrastructure such as water resources and sewage pump stations that are particularly vulnerable to flooding impacts.
- Identification of potential nature-based projects within vulnerable areas.

- The formulation of safety strategies to protect residents and infrastructure during severe weather events.
- The conservation of valuable wetland ecosystems.
- Adherence to suggestions in the LENOWISCO PDC's Hazard Mitigation Plan. The Plan will also allow the town to apply for additional grants from the Community Flood Preparedness Fund to implement any suggested changes.

**Deliverable 1: Flood risk data compiled**

*Task 1.1.* Hire Consultant

*Task 1.2.* Consultant compiles existing data and conducts preliminary survey

*Task 1.3.* Consultant develops site and watershed concepts

**Deliverable 2: Two employees trained as Certified Floodplain Managers**

*Task 2.1.* Employees attend flood management training

*Task 2.2.* Employees become ASFPM members

*Task 2.3.* Employees successfully complete CFM certification

*Task 2.4.* Employees maintain ASFPM and CFM certifications

**Deliverable 3: Creation of a Community Flood Preparedness Scoping Plan**

*Task 3.1.* Site and watershed concepts are made available for public review and comment

*Task 3.2.* Two public meetings are held to gather feedback

*Task 3.3.* The draft Scoping Plan is made available to local stakeholders for review

*Task 3.4.* The draft Scoping Plan is made available for public review

*Task 3.5.* Consultants deliver completed Scoping Plan to the Town

***Timeline***

Upon notification of the award and receiving the funding, Pennington Gap plans to complete most deliverables by the end of Fourth Quarter 2024. The exception is the continued maintenance of employees' ASFPM membership, which will last for three years. In the case of any extenuating circumstances such as a natural disaster or other emergency, Pennington Gap will update DCR with any proposed schedule changes as soon as possible.

**March 15th, 2024**

- Consultant procurement and establishment of project terms and conditions.

**May 1st, 2024**

- Consultant begins survey work.
- Pennington Gap employees begin studying for CFM exam.

**August 1st, 2024**

- Public outreach period for draft site and watershed concepts begins.
- Date is set for public input meeting.

### August 31st, 2024

- Public outreach period concludes.

### September 30th, 2024

- Pennington Gap employees schedules CFM exam to be taken prior to December 1st, 2024
- Deadline for participation in FEMA Emergency Institute course.

### October 15th, 2024

- Draft Scoping Plan is distributed to key stakeholders (described below) for feedback.

### November 1st, 2024

- Draft Scoping Plan is made available to the public for review.

### December 1st, 2024

- Deadline for employees to have completed CFM exams.
- Deadline for second community listening session.

### December 13th, 2024

- Finalized survey and Scoping Plan are delivered to Pennington Gap; project concludes.

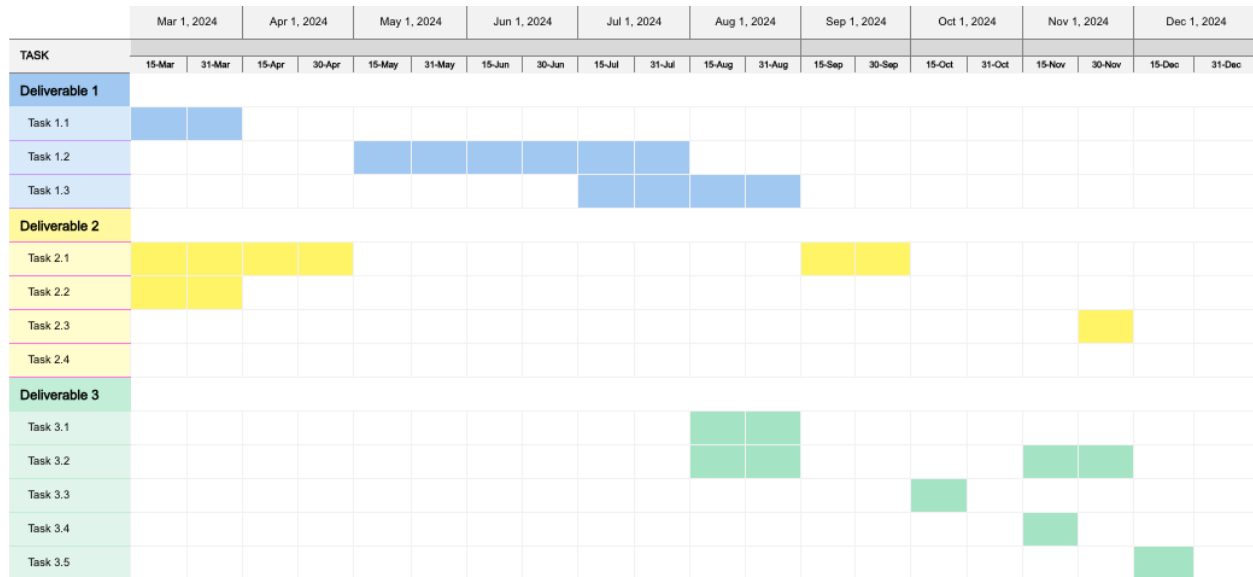

### Key Stakeholders

This project will engage and impact several key stakeholders, including town executive leadership, town employees, residents, county agency officials, public community organizations, and regional partners. Town government, including the Parks and Recreation Department and the local police department, and other stakeholders who regularly use the involved floodplains will be especially important during this process. Pennington Gap will also be partnering closely with regional non-profit Appalachian Voices during this process, which has an existing network of community members who will be invited to public meetings. In order to effectively engage all

stakeholders during this process, Pennington Gap proposes to host a 30-day online public input period, as well as a public hearing during a regular town council meeting to solicit community feedback. The feedback will be reviewed by the Consultant, city staff, and Appalachian Voices to incorporate into the Community Flood Preparedness Scoping Plan.

***Estimated Cost***

No current member of town staff is a Certified Floodplain Manager (CFM). Part of this funding request for capacity building is so that the Town may train and certify two staff members as CFMS. The Town has identified a training course at the FEMA Emergency Institute in Emmitsburg, MD that is offered in February, March, April, and September 2024. The cost will include travel, lodging, meals, and the training itself, although training will be free if staff is accepted at the Institute.

For travel, we estimate 900 miles round trip for two staff members using personal vehicles. Mileage reimbursement is \$0.65/mile. Using IRS rates, we estimate \$856 for eight nights of lodging and \$412 for the per diem. According to the Association of State Flood Plain Managers (ASFPM), the exam fee for nonmembers is \$565 and \$185 for members. Both staff will become ASFPM members at \$165 each. Given the limited funds available in Pennington Gap, we also request membership dues for the next two years to ensure that the town has sustained floodplain management capacity.

The creation of the master flood preparedness plan will require procurement of floodplain management and hydrology experts, as well as contracted labor from economic development and community engagement professionals. We estimate the total cost of creating the study and carrying out the community engagement at approximately \$44,600, with \$2,500 of that earmarked for community engagement and \$42,100 for the plan itself.

<b>Item</b>	<b>Unit Cost</b>	<b>Unit</b>	<b>Quantity</b>	<b>Cost</b>	<b>Notes</b>
Training Class	\$750.00	Each	2	\$1500	Max. cost based on acceptance
Travel	.65	Miles	1800	\$1179	IRS rate
Lodging	\$107.00	Day	8	\$856	IRS rate
Per Diem	\$59.00	Day	8	\$412	\$44 per diem on first and last days of travel
ASFPM Dues	\$165.00	Each	6	\$990	Three years of dues for two staff
Exam	\$185.00	Each	2	\$370	Discounted rate for ASFPM

					members
Community outreach Consultant Labor	\$20.43	Hours	40	\$817	Anticipated contract labor with Appalachian Voices community engagement and economic development experts
Engineering Consultant Labor	\$41,376			\$41,376	Anticipated contract labor for floodplain management and landscaping professionals, and conservationists.
Community Outreach	\$2,500			\$2,500	Will include website creation, advertisement, public gatherings
<b>Total Cost</b>				<b>\$50,000</b>	

### Amount Requested

Pennington Gap is classified as a low-income locality, with a median household income of just over \$19,400 compared to the state average of approximately \$85,000. That classification reduces Pennington Gap's required match to 10% of requested funds. With the total cost estimated at \$50,000, the town would like to request that the match be waived. In the case that the match is unable to be waived, the town requests \$45,000 or 90% of the estimated total cost from the fund and will in turn provide the remaining \$5,000.

### Current Planning Documents

Please find current locality planning documents listed and linked or attached below.

- 1) Pennington Gap's 2022 Comprehensive Plan, [linked here](#).
- 2) Pennington Gap Greenway Survey, attached below.
- 3) Lenowisco 2021 Hazard Mitigation Study, [linked here](#).
- 4) Lee County 2020 Comprehensive Plan, [linked here](#).



# CONSTRUCTION PLANS FOR LEEMAN FIELD GREENWAY PROJECT PHASE I - VII

TOWN OF PENNINGTON GAP, VIRGINIA  
Lee County

VIRGINIA DEPARTMENT OF TRANSPORTATION  
PROJECT NO. EN07-281-104, P101, C501 (UPC87001)

## DRAWING INDEX

SHEET NO.	SHEET NAME
_____	TITLE SHEET
C1.0	GREENWAY ENTRANCE AND PARKING LOT
C2.0	PLAN AND PROFILE STA. 0+00 TO STA. 13+75
C2.1	TRAIL NO. 2 PLAN AND PROFILE
C2.2	ALT. NO. 2 PLAN VIEW
C3.0	PLAN AND PROFILE STA. 13+75 TO STA. 27+50
C4.0	PLAN AND PROFILE STA. 27+50 TO STA. 41+25
C5.0	PLAN AND PROFILE STA. 41+25 TO STA. 55+00
C6.0	PLAN AND PROFILE STA. 55+00 TO STA. 68+75
C6.1	PEDESTRIAN BRIDGE DETAILS
C7.0	PLAN AND PROFILE STA. 68+75 TO STA. 71+84
C8.0	TRAIL NO. 3 PLAN AND PROFILE
C9.0	GREENWAY LOCATION AT LEEMAN FIELD
D1.0	CONSTRUCTION DETAILS
D2.0	CONSTRUCTION DETAILS
D3.0	CONSTRUCTION DETAILS
X1.0 - X23.0	CROSS SECTIONS

FUNDING PROVIDED BY:

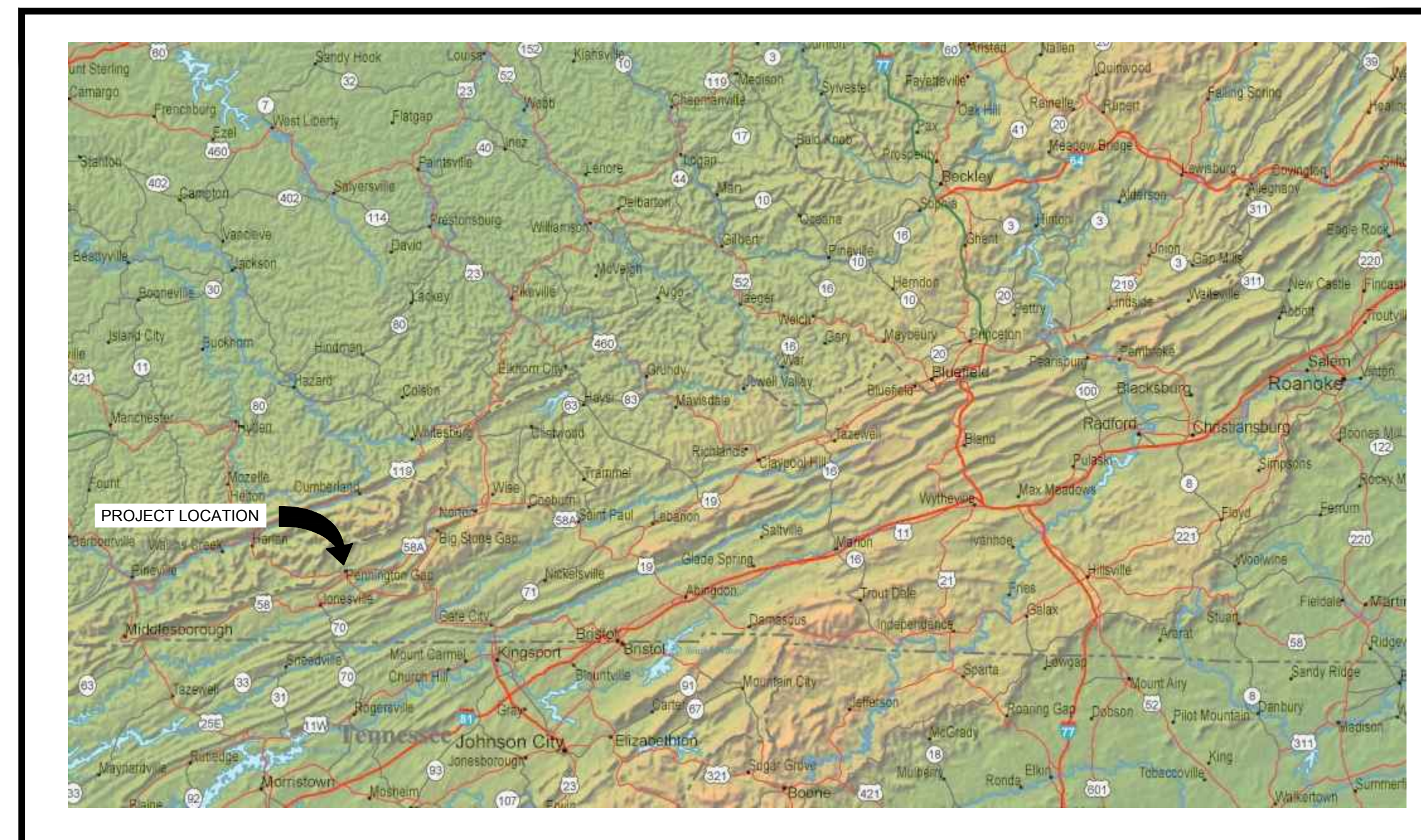

SOUTHWEST VIRGINIA

NOT TO SCALE

CALL BEFORE YOU DIG!



Dig With C.A.R.E. Keep Virginia Safe!

Call Miss Utility @ 811 before you dig.

Allow required time for marking.

Respect the marks.

Excavate carefully.



Dig With C.A.R.E. Call Miss Utility @ 811

CONTACT INFORMATION:

TOWN OF PENNINGTON GAP - HONORABLE D.R. CARTER, MAYOR  
CONSULTANT - MR. ANDY T. MILES, P.E. (VAUGHN & MELTON)

OWNER:



TOWN OF PENNINGTON GAP  
131 CONSTITUTION ROAD  
PENNINGTON GAP, VIRGINIA 24277  
PHONE: (276) 546-1177  
FAX: (276) 546-5383  
www.townofpennington.com

APPROVED FOR CONSTRUCTION:

TOWN REPRESENTATIVE

DATE

UTILITY NOTE

The existing utilities shown hereon have been located from a field survey. The Engineer makes no guarantee that the UNDERGROUND utilities shown comprise all such utilities in the area, either in service or abandoned. The Engineer does certify that they are located as accurately as possible from the information available. The Engineer has not physically located the underground utilities. The contractor is responsible for locating any and all utilities prior to any construction.



Engineering - Surveying

127 BOB FITZ ROAD - SUITE 2  
GRAY, TENNESSEE 37615  
PHONE: (423) 467-8401 FAX: (423) 467-8402

KENTUCKY  
606-248-6600

TENNESSEE  
865-546-5800

NORTH CAROLINA  
828-253-2796

SOUTH CAROLINA  
864-574-4775

www.vaughnmelton.com

Copyright ©2012  
All Rights Reserved

UTILITY PROVIDERS:

ELECTRIC - ?

SEWER - ?

WATER - ?

PHONE - ?

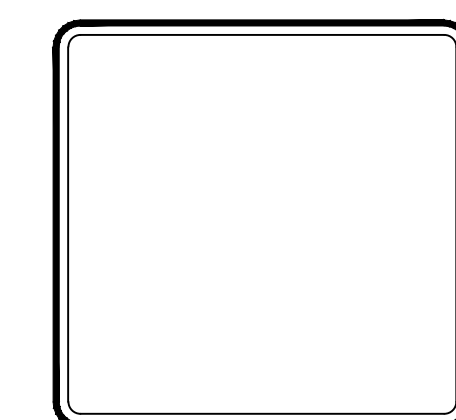

CIVIL ENGINEER  
FOR REVIEW ONLY 13 MAR 2012



3/13/2012

T:\Civil\51120-55\Data\Drawings\51120-55\_Proposed Layout.dwg

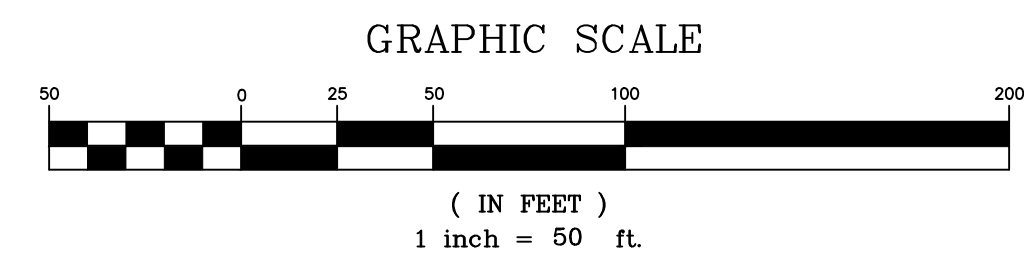
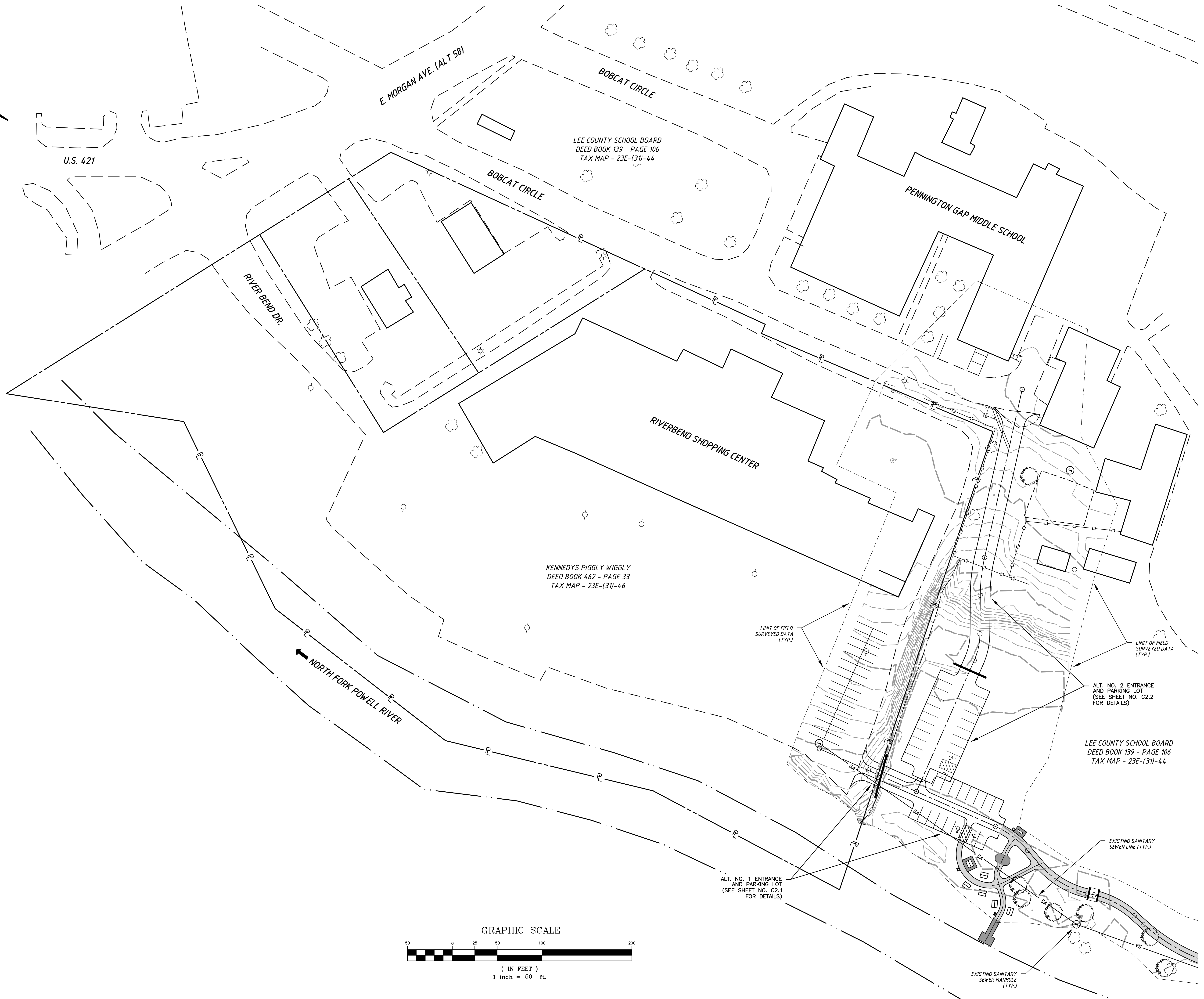
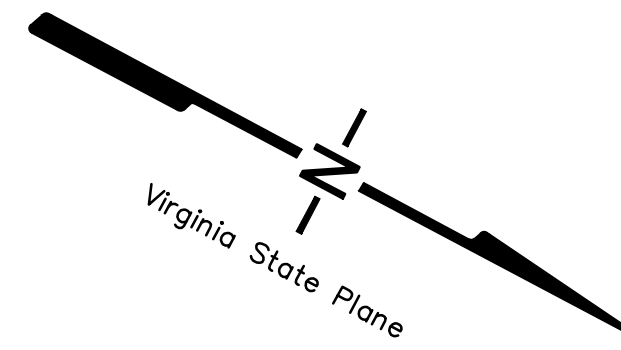

NO.	DATE	DESCRIPTION

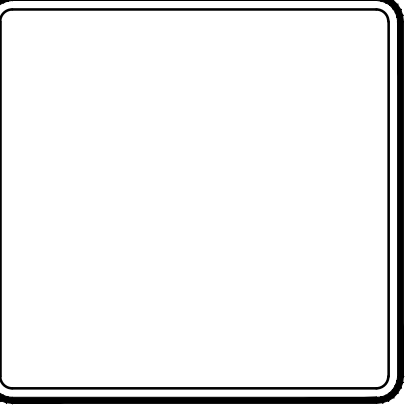

PHASE I-VII  
**LEEMAN FIELD GREENWAY**  
 Pennington Gap, Virginia

**V&M**  
**Vaughn & Melton**  
 Engineering - Surveying

KENTUCKY  
606-248-6600

TENNESSEE  
865-546-5800

NORTH CAROLINA  
828-253-2796

SOUTH CAROLINA  
864-574-4775

www.vaughnmelton.com  
 Copyright ©2012  
 All Rights Reserved

DRAWN:	R.C.D.
CHECKED:	A.T.M.
JOB NO:	51120-55
SCALE:	1"=50'
DATE:	----
FILE NAME:	51120-55_Proposed Layout.dwg
DRAWING TITLE:	GREENWAY ENTRANCE AND PARKING LOT ALT. NO. 1 & NO. 2
SHEET	DRAWING NO.
OF	<b>C1.0</b>





3/14/2012

T:\Civil\51120-55\Data\Drawings\51120-55\_Proposed Layout.dwg

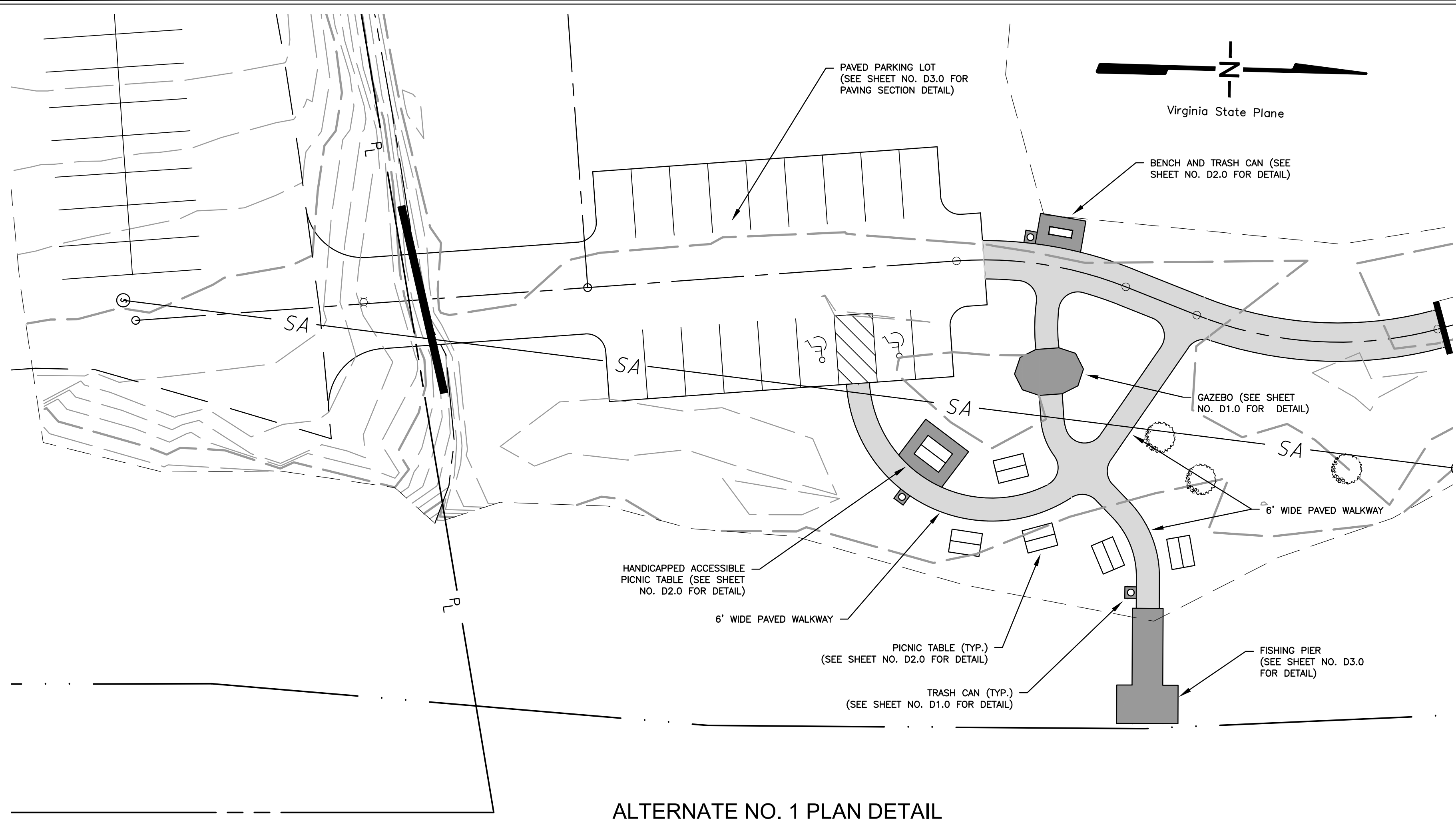

ALTERNATE NO. 1 PLAN DETAIL  
SCALE 1 inch = 20 feet

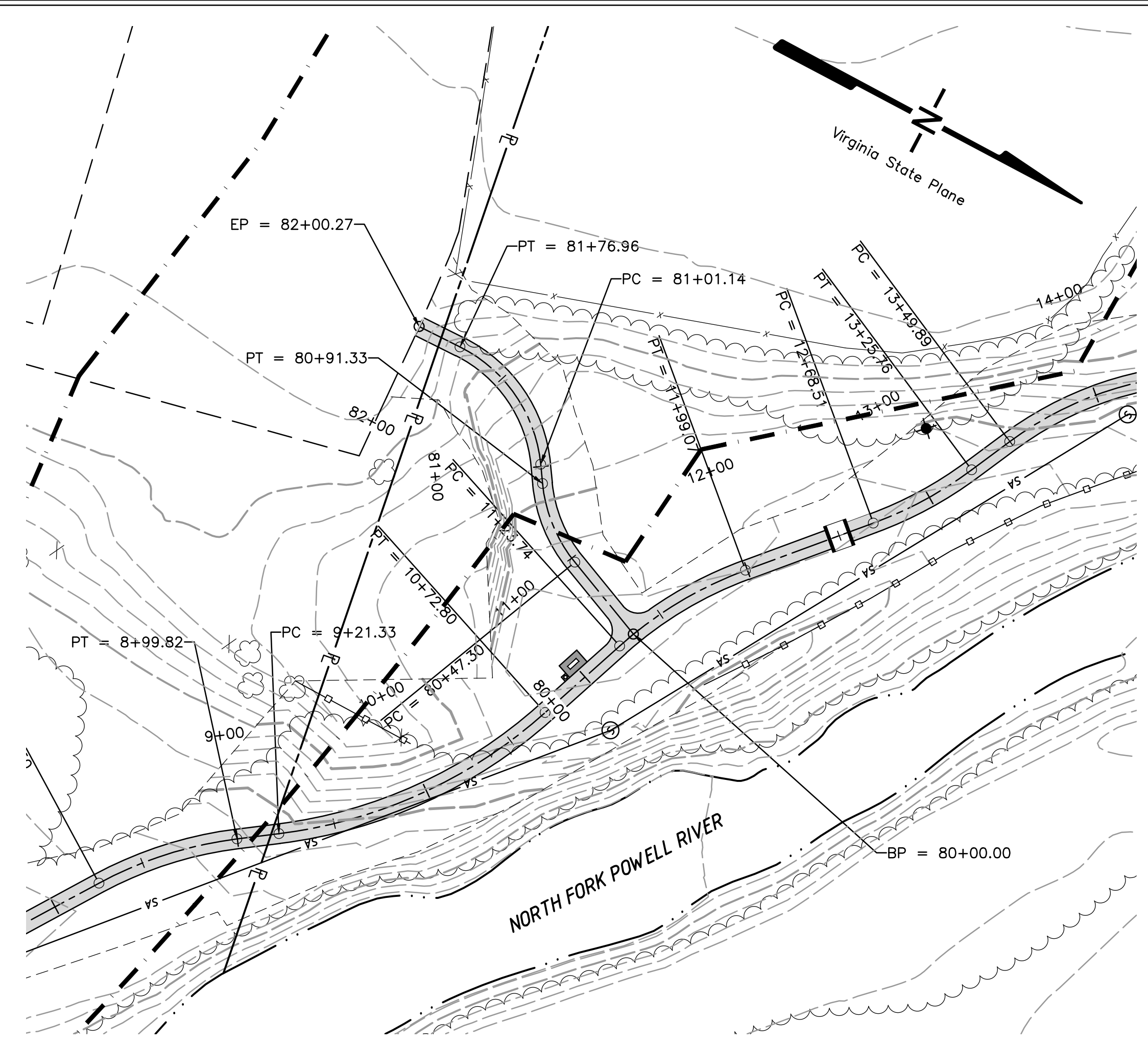

TRAIL NO. 2 PLAN VIEW  
SCALE 1 inch = 50 feet

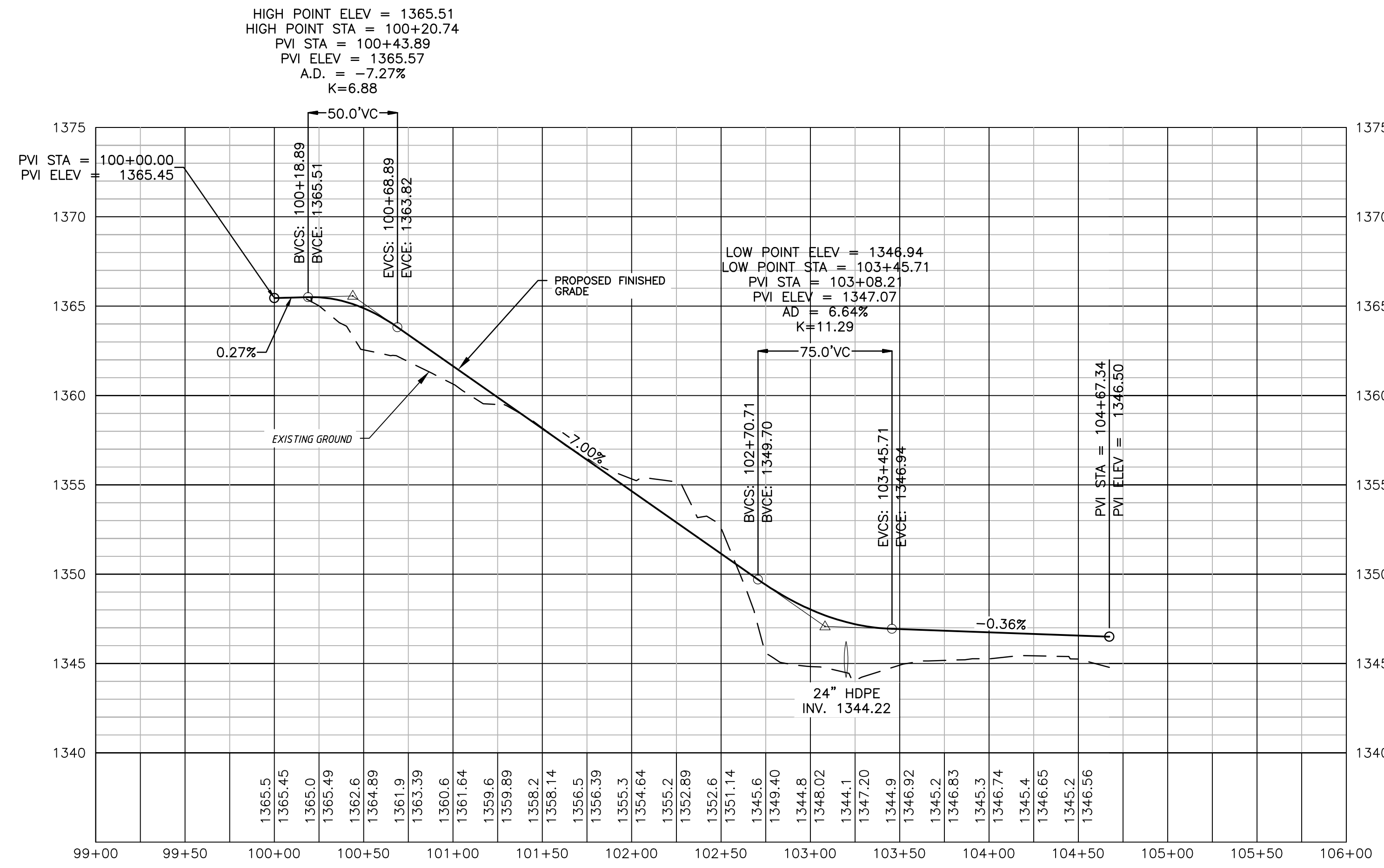

ALTERNATE NO. 2 PROFILE  
SCALE 1 inch = 50 feet Horiz.  
1 inch = 5 feet Vert.

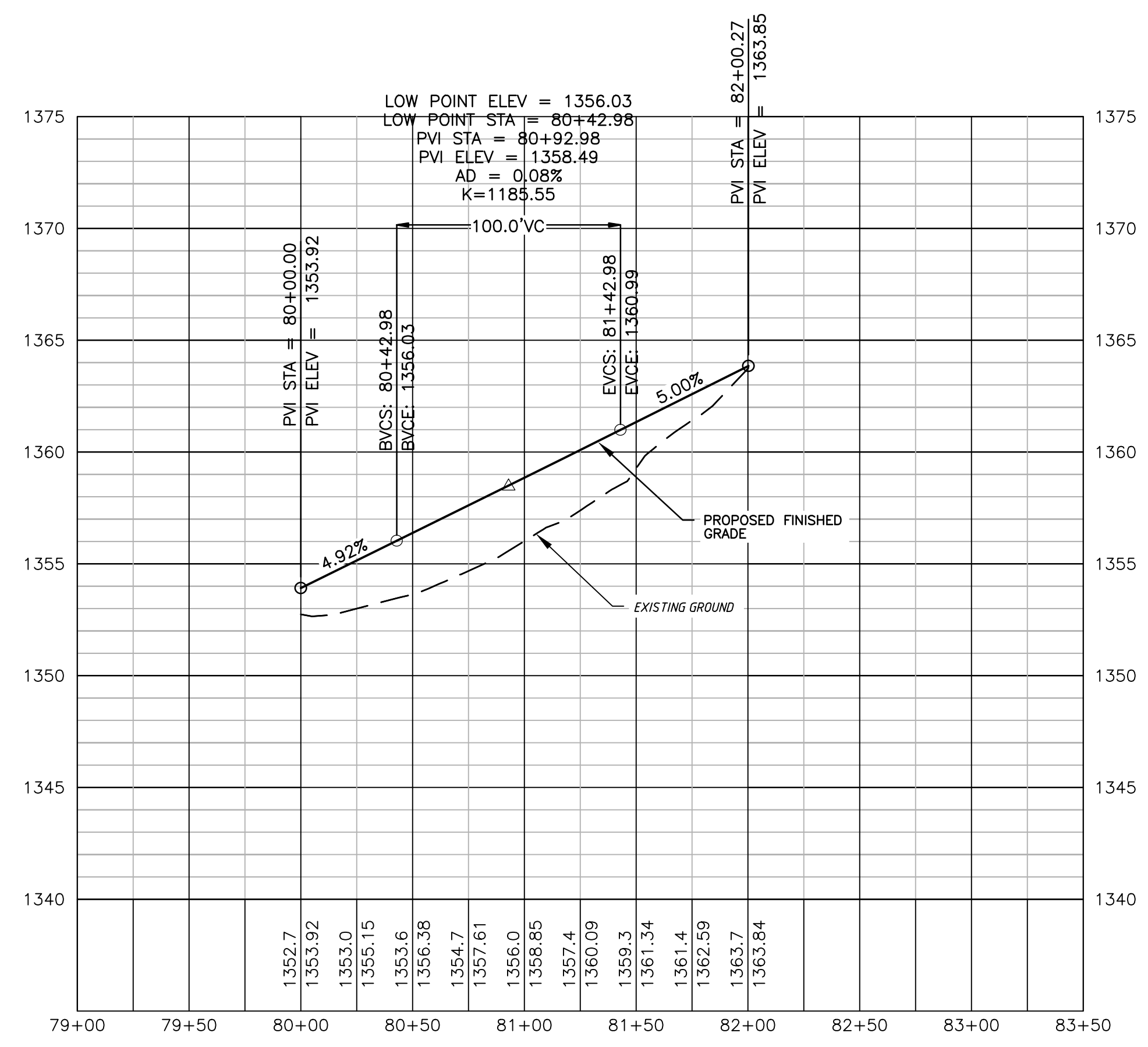

TRAIL NO. 2 PROFILE  
SCALE 1 inch = 50 feet Horiz.  
1 inch = 5 feet Vert.

NO.	DATE	DESCRIPTION

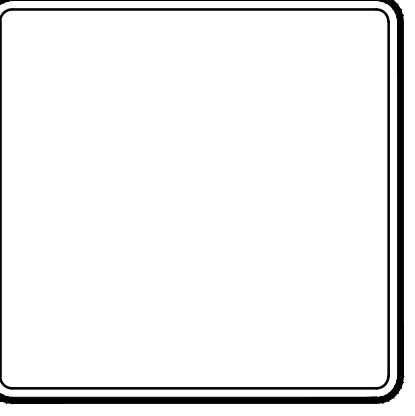

PHASE I-VII  
**LEEMAN FIELD GREENWAY**  
Pennington Gap, Virginia

**V&M**  
Vaughn & Melton  
Engineering - Surveying  
KENTUCKY  
606-248-6600  
TENNESSEE  
865-546-5800  
NORTH CAROLINA  
828-253-2796  
SOUTH CAROLINA  
864-574-4775  
www.vaughnmelton.com  
Copyright © 2012  
All Rights Reserved

DRAWN:	R.C.D.
CHECKED:	A.T.M.
JOB NO:	51120-55
SCALE:	1"=50'
DATE:	----
FILE NAME:	51120-55_Proposed Layout.dwg
DRAWING TITLE:	PLAN AND PROFILE TRAIL NO. 2 PARKING AREA
SHEET	DRAWING NO.
OF	<b>C2.1</b>

T:\Civil\51120-55\Data\Drawings\51120-55\_Proposed Layout.dwg

3/13/2012

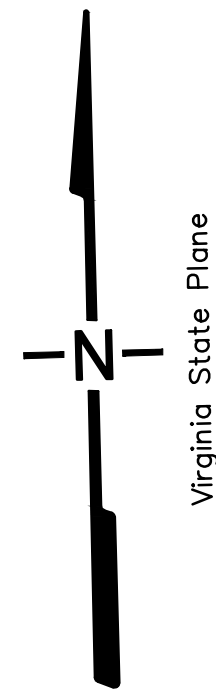

ALTERNATE NO. 2 PLAN DETAIL

SCALE 1 inch = 20 feet

NO.	DATE	DESCRIPTION

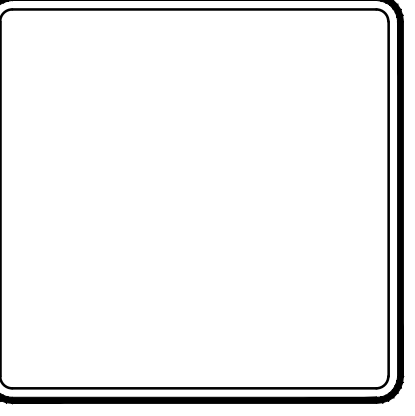

PHASE I-VII  
**LEEMAN FIELD GREENWAY**  
 Pennington Gap, Virginia

**V&M**  
**Vaughn & Melton**  
 Engineering - Surveying  
 KENTUCKY  
 606-248-6600  
 TENNESSEE  
 865-546-5800  
 NORTH CAROLINA  
 828-253-2796  
 SOUTH CAROLINA  
 864-574-4775  
 www.vaughnmelton.com  
 Copyright © 2012  
 All Rights Reserved

DRAWN:	R.C.D.
CHECKED:	A.T.M.
JOB NO:	51120-55
SCALE:	1" = 20'
DATE:	----
FILE NAME:	51120-55_PROPOSED_LAYOUT.DWG
DRAWING TITLE:	

SHEET	DRAWING NO:
----	ALT. NO. 2
OF	PLAN VIEW
----	<b>C2.2</b>



3/13/2012

T:\Civil\51120-55\Data\Drawings\51120-55\_Proposed Layout.dwg

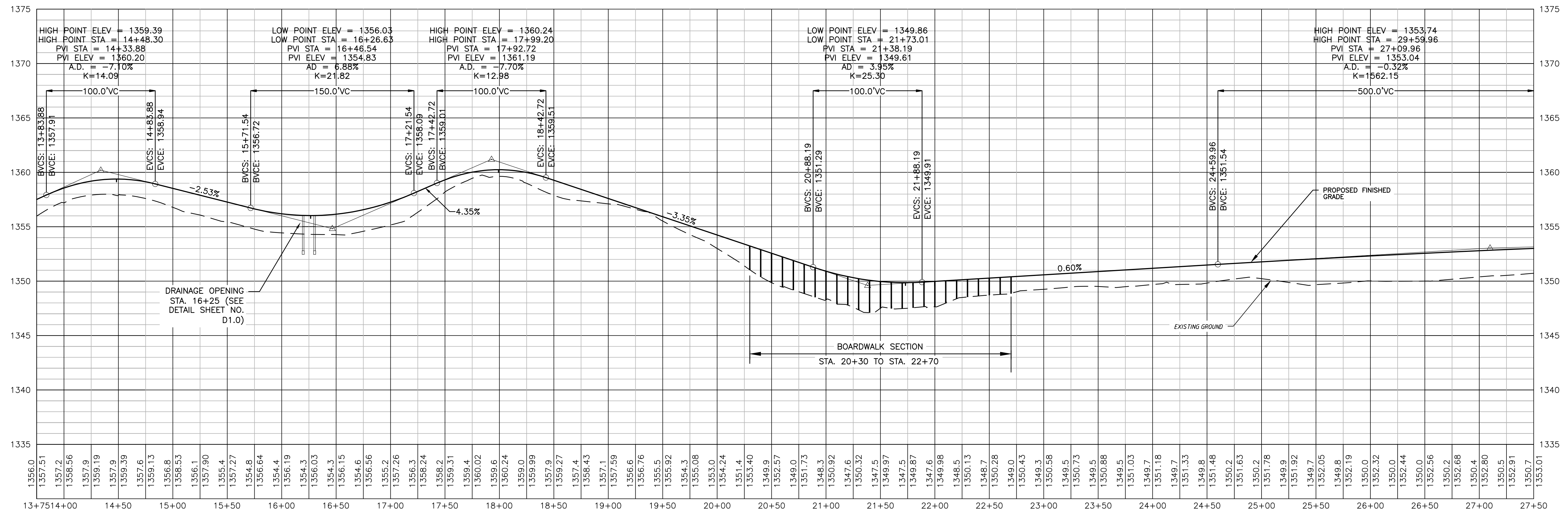
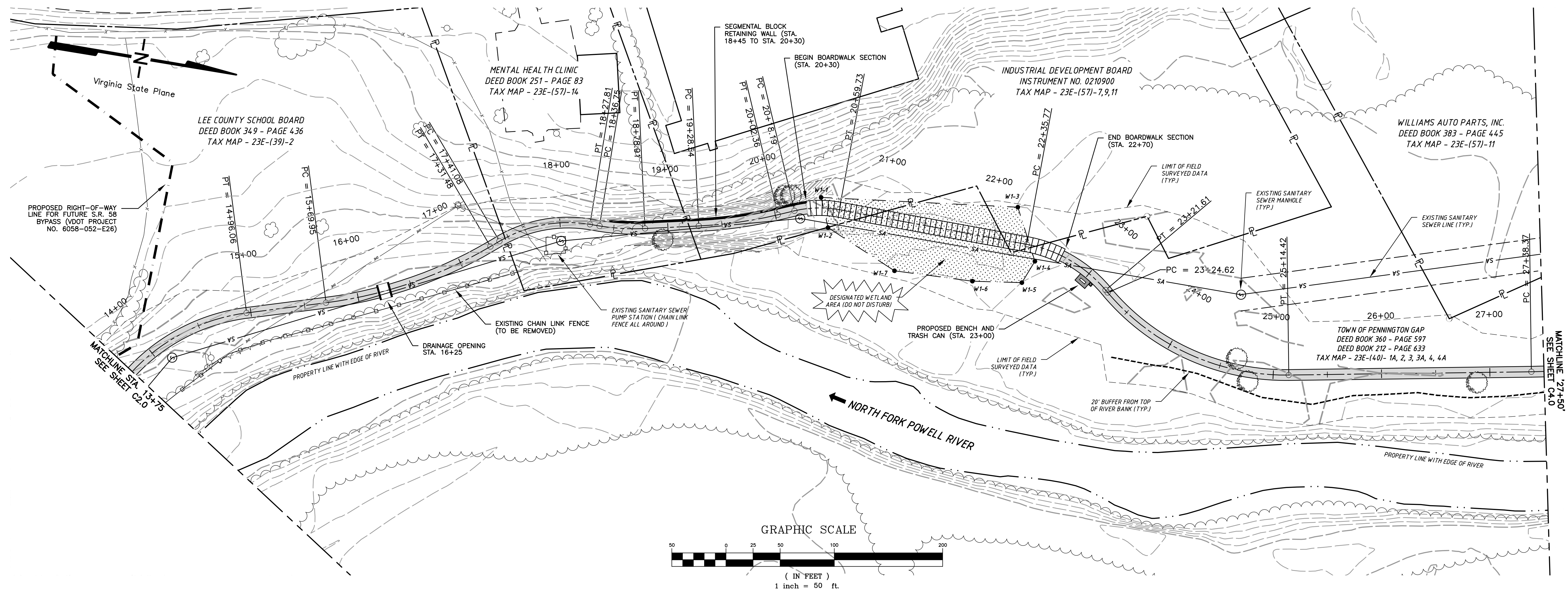

NO.	DATE	DESCRIPTION

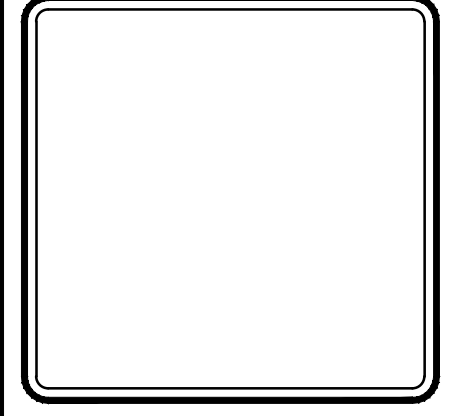

PHASE I-VII  
**LEEMAN FIELD GREENWAY**  
Pennington Gap, Virginia

**V&M**  
Vaughn & Melton  
Engineering - Surveying  
KENTUCKY 606-248-6600  
TENNESSEE 865-546-5800  
NORTH CAROLINA 828-253-2796  
SOUTH CAROLINA 864-574-4775  
www.vaughnmelton.com  
Copyright © 2012 All Rights Reserved

DRAWN: R.C.D.	CHECKED: A.T.M.
JOB NO: 51120-55	SCALE: 1"=50'
DATE: ---	FILE NAME: 51120-55_Proposed Layout.dwg
DRAWING TITLE: <b>PLAN AND PROFILE STA. 13+75 TO STA. 27+50</b>	
SHEET OF	DRAWING NO: <b>C3.0</b>

3/13/2012

T:\Civil\51120-55\Data\Drawings\51120-55\_Proposed Layout.dwg

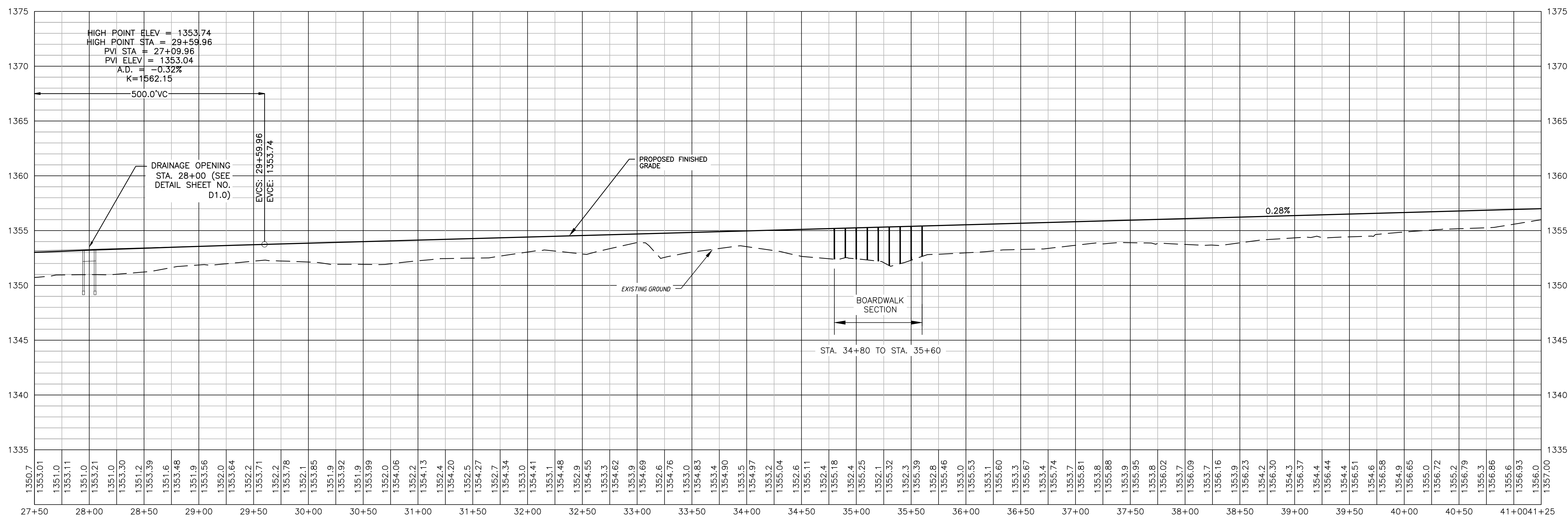
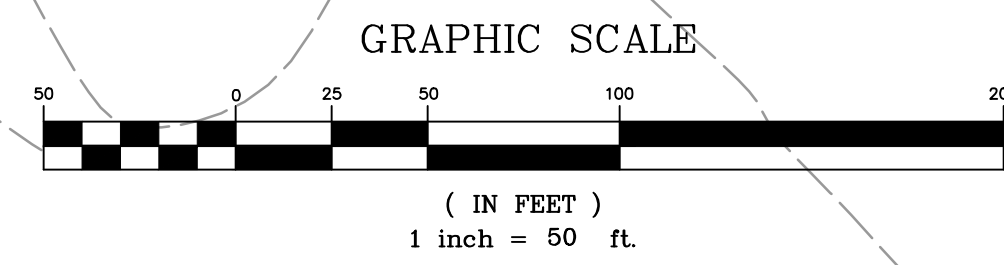
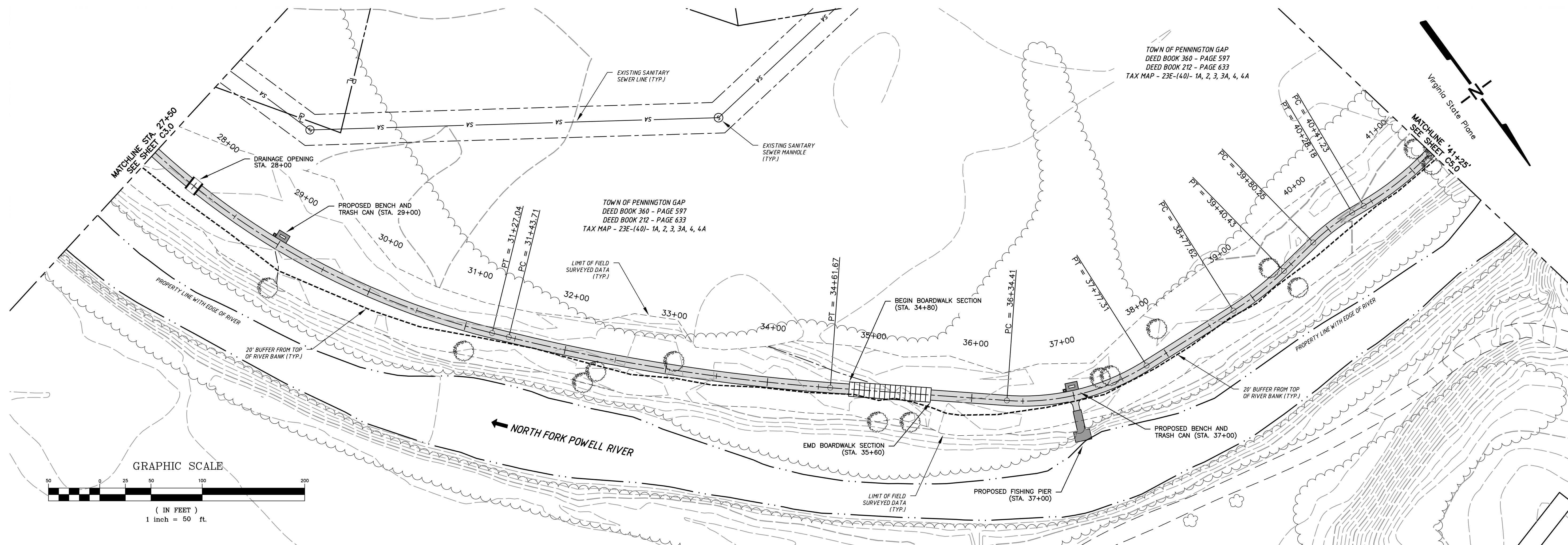

NO.	DATE	DESCRIPTION

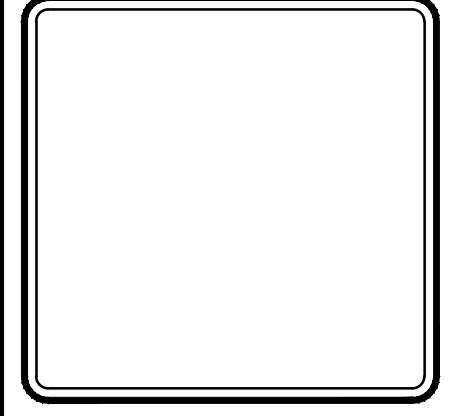

**PHASE I-VII**  
**LEEMAN FIELD GREENWAY**  
Pennington Gap, Virginia

**V&M**  
**Vaughn & Melton**  
Engineering - Surveying  
KENTUCKY  
606-248-6600  
TENNESSEE  
865-546-5800  
NORTH CAROLINA  
828-253-2796  
SOUTH CAROLINA  
864-574-4775  
www.vaughnmelton.com  
Copyright ©2012  
All Rights Reserved

DRAWN:	R.C.D.
CHECKED:	A.T.M.
JOB NO:	51120-55
SCALE:	1"=50'
DATE:	----
FILE NAME:	51120-55-PROPOSED LAYOUT.DWG
DRAWING TITLE:	

**PLAN AND PROFILE**  
STA. 27+50 TO  
STA. 41+25

SHEET	DRAWING NO.
OF	<b>C4.0</b>



3/13/2012

T:\Civil\51120-55\Data\Drawings\51120-55\_Proposed Layout.dwg

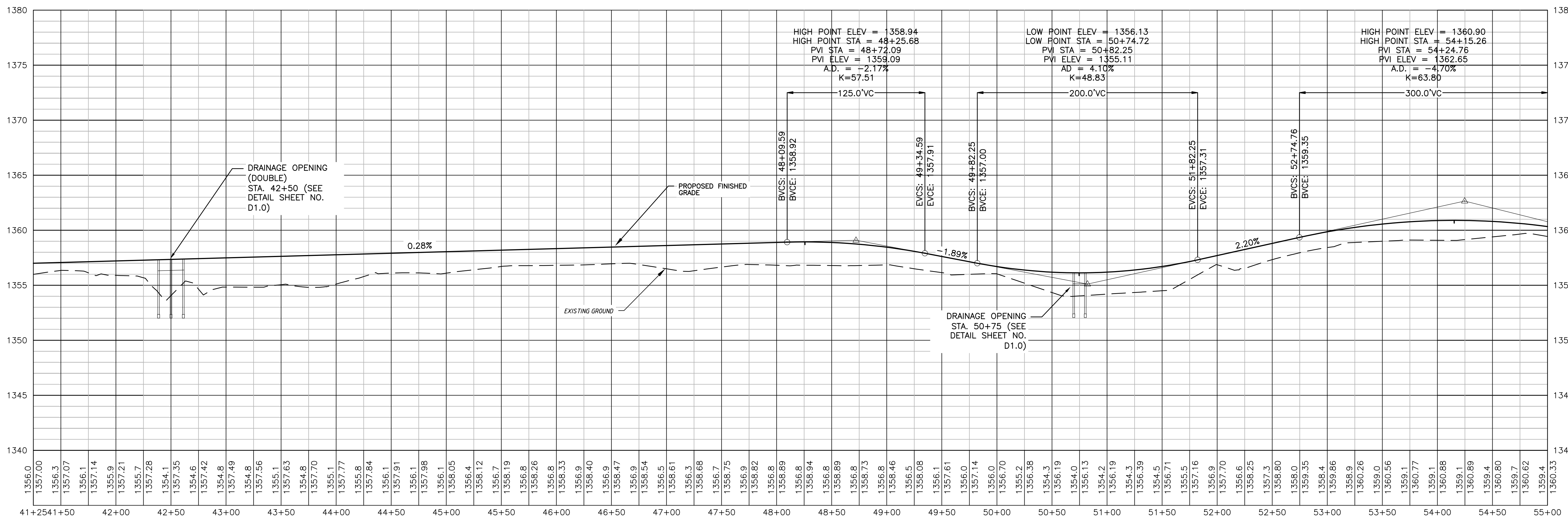
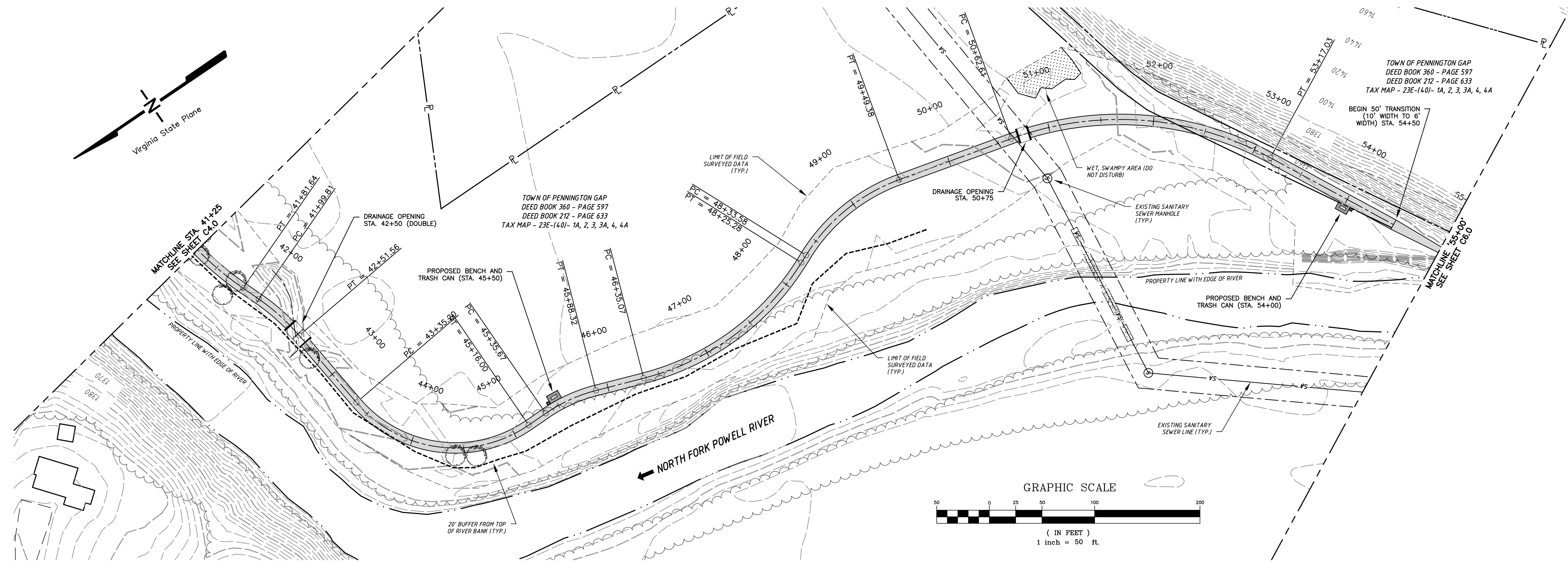

NO.	DATE	DESCRIPTION

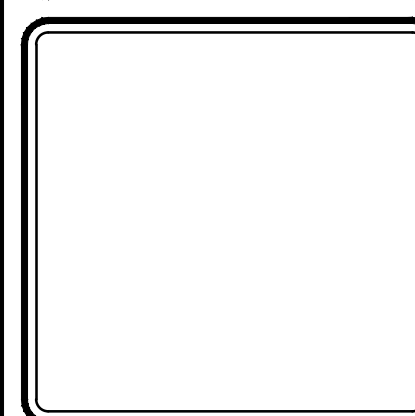

PHASE I-VII  
**LEEMAN FIELD GREENWAY**  
Pennington Gap, Virginia

**V&M**  
Vaughn & Melton  
Engineering - Surveying

KENTUCKY  
606-248-6600

TENNESSEE  
865-546-5800

NORTH CAROLINA  
828-253-2796

SOUTH CAROLINA  
864-574-4775

www.vaughnmelton.com  
Copyright ©2012  
All Rights Reserved

DRAWN: R.C.D.
CHECKED: A.T.M.
JOB NO: 51120-55
SCALE: 1"=50'
DATE: ---
FILE NAME: 51120-55-PROPOSED LAYOUT.DWG
DRAWING TITLE: <b>PLAN AND PROFILE STA. 41+25 TO STA. 55+00</b>
SHEET OF: <b>C5.0</b>

3/14/2012

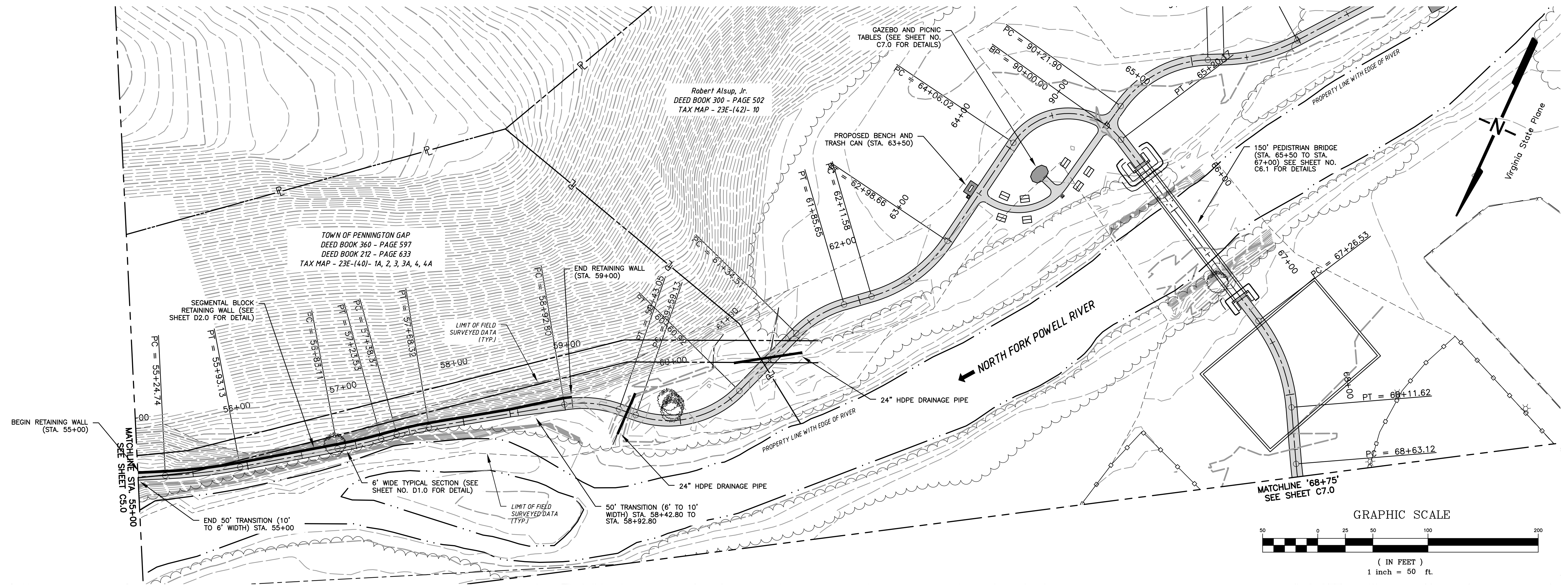

T:\Civil\51120-55\Data\Drawings\51120-55\_Proposed Layout.dwg

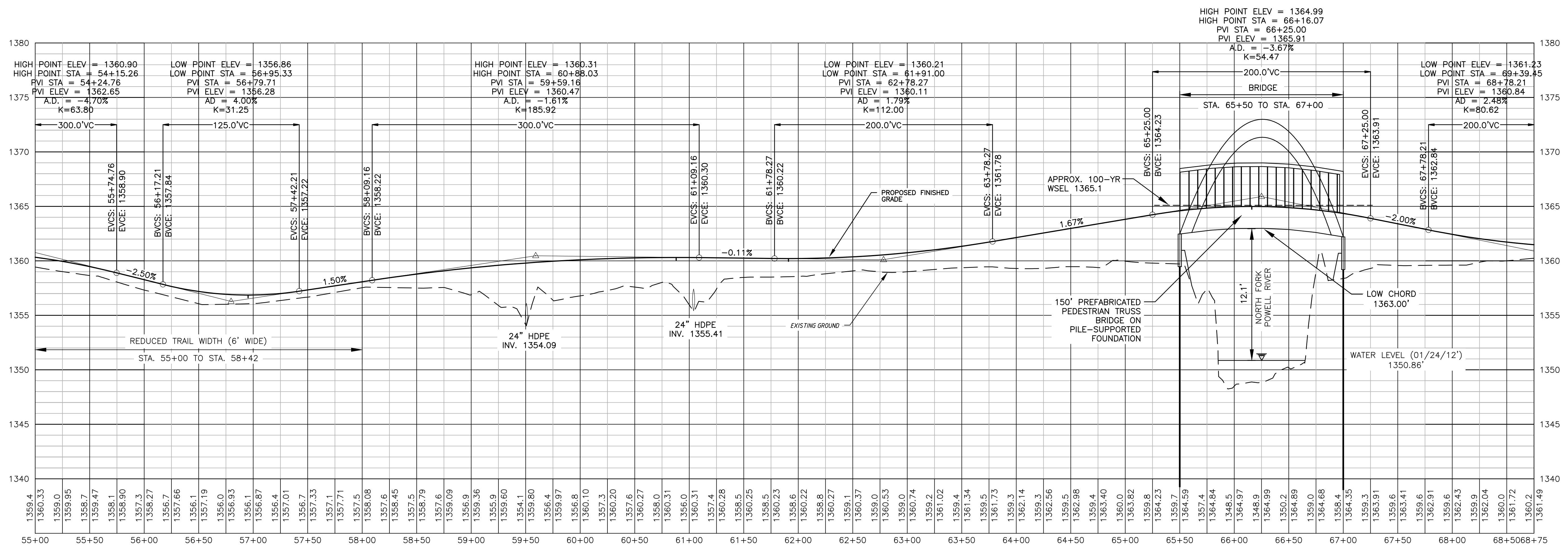

NO.	DATE	DESCRIPTION

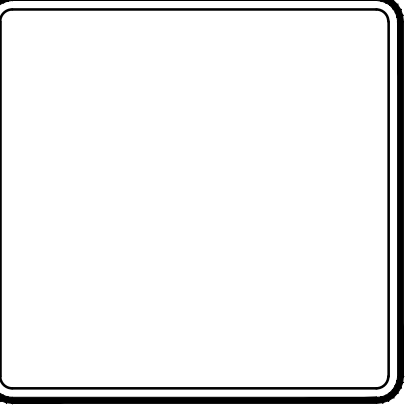

PHASE I-VII  
**LEEMAN FIELD GREENWAY**  
Pennington Gap, Virginia

**V&M**  
Vaughn & Melton  
Engineering - Surveying

KENTUCKY  
606-248-6600

TENNESSEE  
865-546-5800

NORTH CAROLINA  
828-253-2796

SOUTH CAROLINA  
864-574-4775

www.vaughnmelton.com  
Copyright © 2012  
All Rights Reserved

DRAWN: R.C.D.
CHECKED: A.T.M.
JOB NO: 51120-55
SCALE: 1"=50'
DATE: ---
FILE NAME: 51120-55_Proposed Layout.dwg
DRAWING TITLE: <b>PLAN AND PROFILE STA. 55+00 TO STA. 68+75</b>
SHEET OF <b>C6.0</b>





PEDESTRIAN BRIDGE DESIGN  
FOR APPEARANCE CONCEPT ONLY

REVISIONS	
NO.	DATE

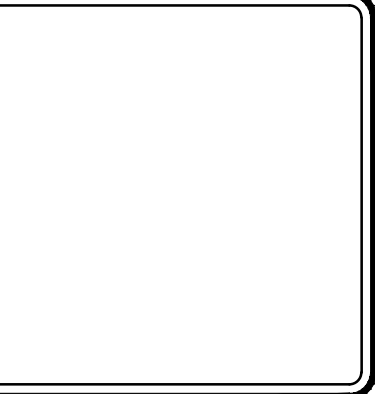

**PHASE I-VII**  
**LEEMAN FIELD GREENWAY**  
 Pennington Gap, Virginia

**V&M**  
**Vaughn & Melton**  
 Engineering - Surveying  
 KENTUCKY  
 606-248-6600  
 TENNESSEE  
 865-546-5800  
 NORTH CAROLINA  
 828-253-2796  
 SOUTH CAROLINA  
 864-574-4775  
 www.vaughnmelton.com  
 Copyright ©2012  
 All Rights Reserved

DRAWN:	R.C.D.
CHECKED:	A.T.M.
JOB NO:	51120-55
SCALE:	AS NOTED
DATE:	----
FILE NAME:	51120-55_PROPOSED_LAYOUT.DWG
DRAWING TITLE:	
<b>PEDISTRIAN BRIDGE DETAILS</b>	

SHEET  
 ---- OF **C6.1**

3/14/2012

T:\Civil\51120-55\Data\Drawings\51120-55\_Proposed Layout.dwg

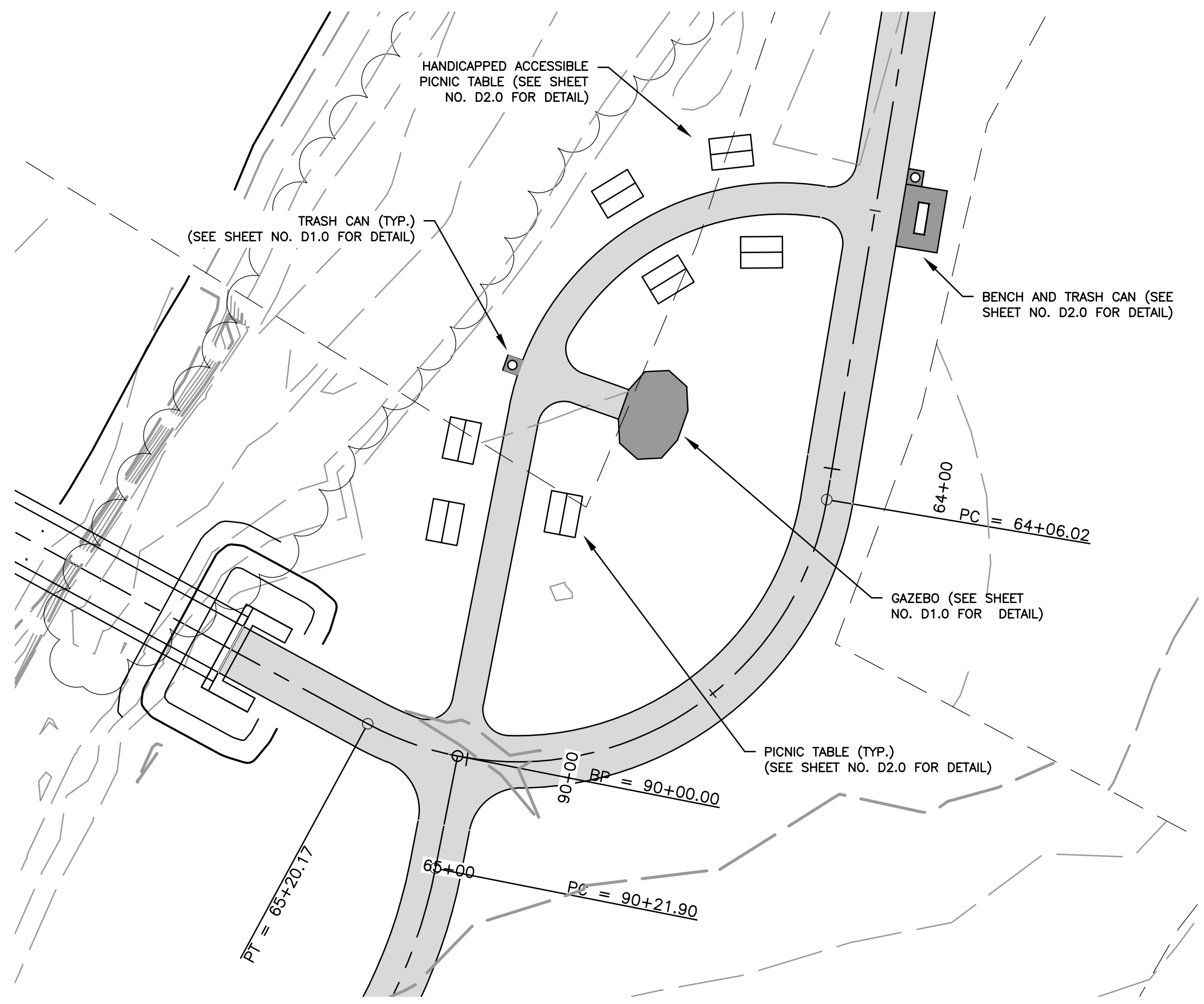
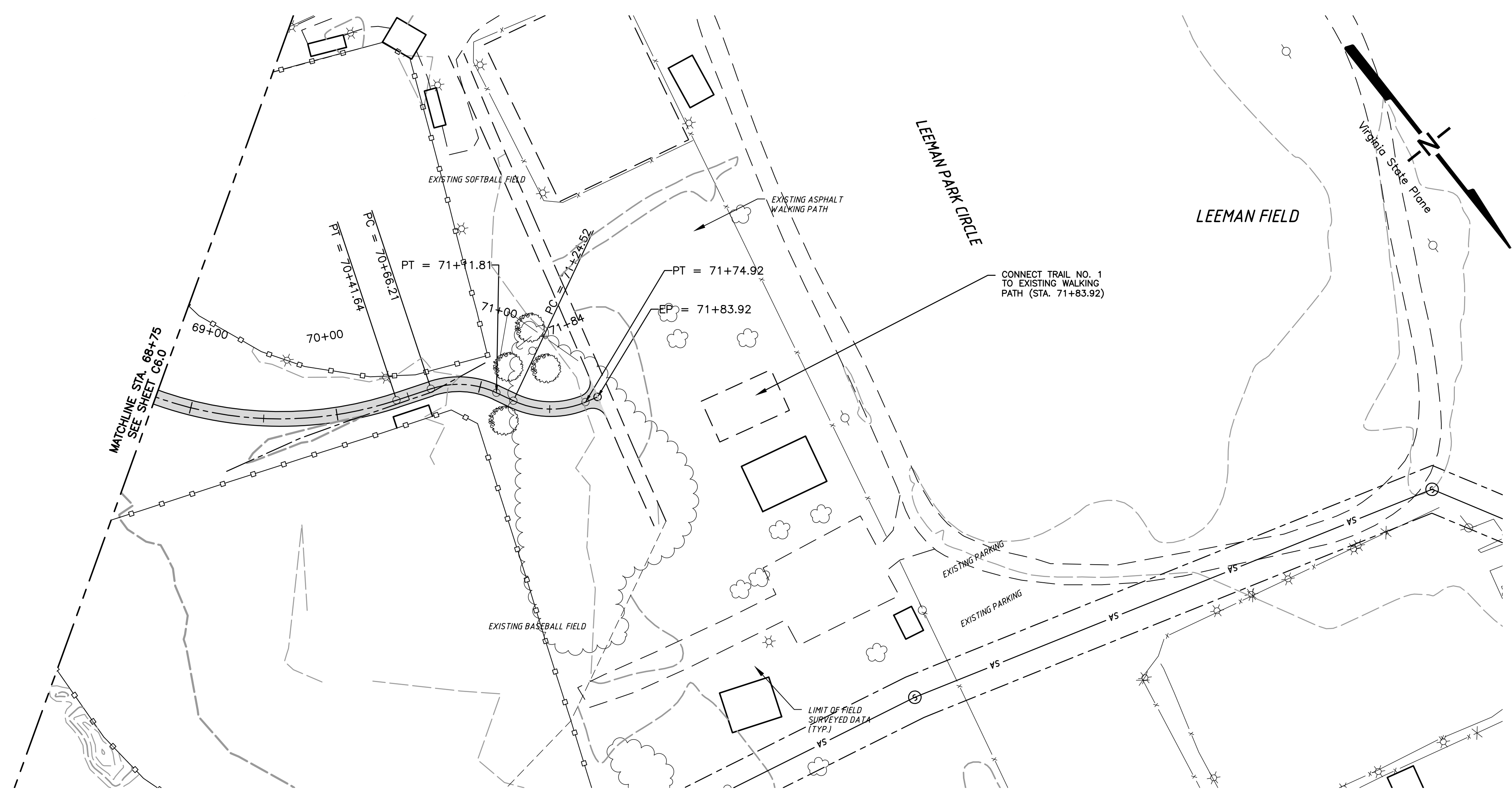
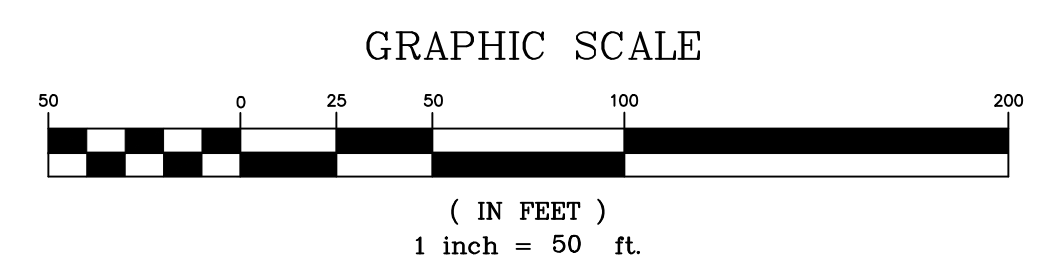

TRAIL AMENITIES AT BRIDGE  
SCALE 1 inch = 20 feet

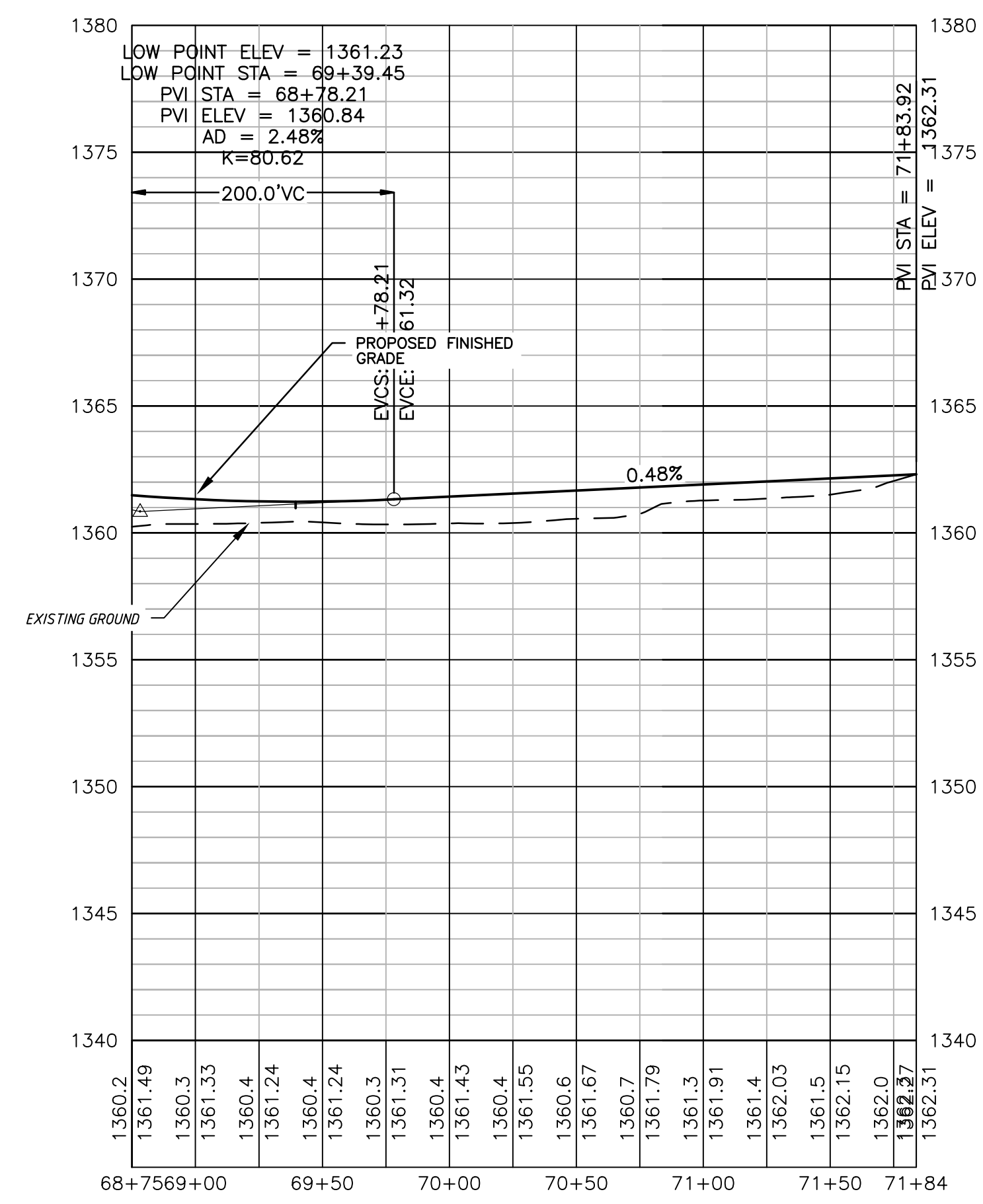

NO.	DATE	DESCRIPTION

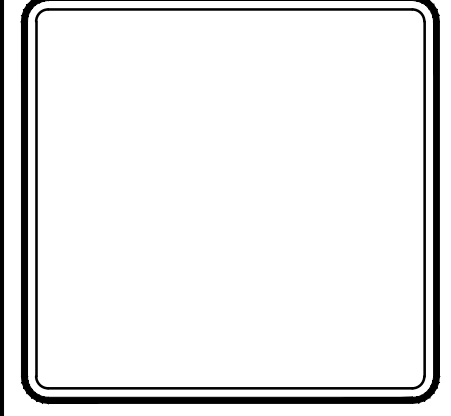

PHASE I-VII  
**LEEMAN FIELD GREENWAY**  
Pennington Gap, Virginia

**V&M**  
Vaughn & Melton  
Engineering - Surveying  
KENTUCKY  
606-248-6600  
TENNESSEE  
865-546-5800  
NORTH CAROLINA  
828-253-2796  
SOUTH CAROLINA  
864-574-4775  
www.vaughnmelton.com  
Copyright © 2012  
All Rights Reserved

DRAWN:	R.C.D.
CHECKED:	A.T.M.
JOB NO:	51120-55
SCALE:	1"=50'
DATE:	---
FILE NAME:	51120-55_Proposed Layout.dwg
DRAWING TITLE:	

PLAN AND PROFILE  
STA. 68+75 TO  
STA. 71+83.92

SHEET	DRAWING NO:
OF	<b>C7.0</b>



T:\Civil\51120-55\Data\Drawings\51120-55\_Proposed Layout.dwg

3/13/2012

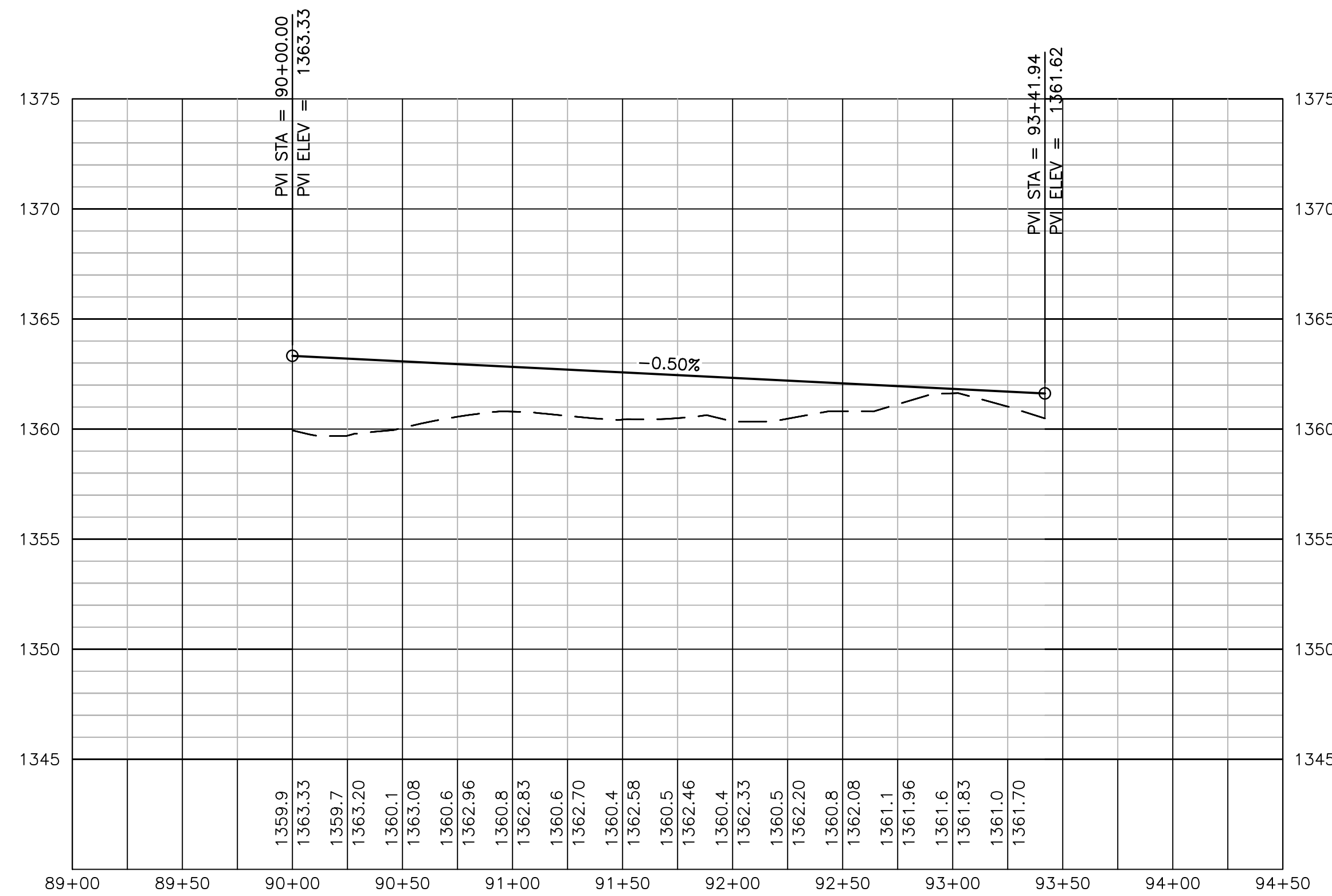
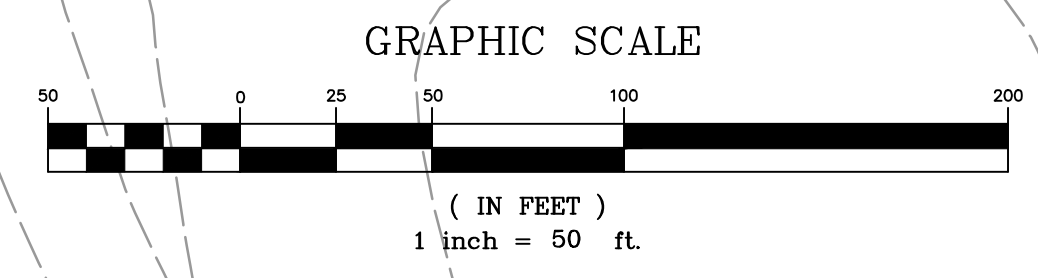
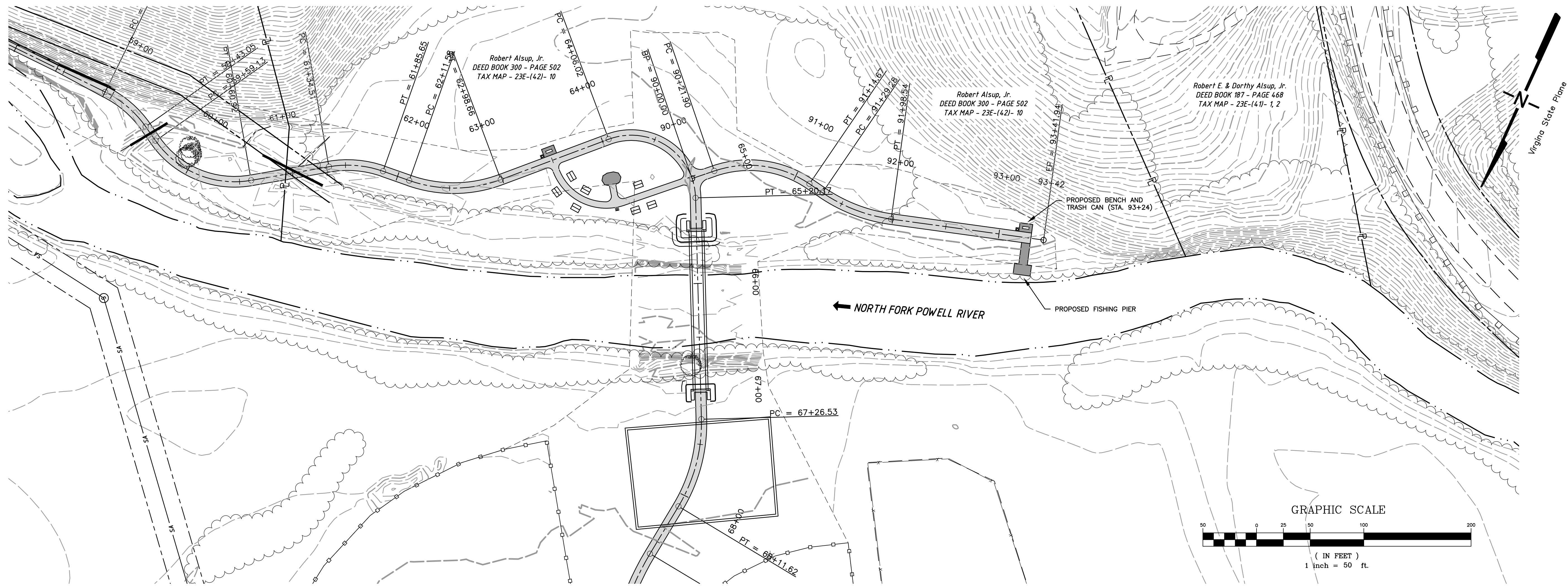

TRAIL NO. 3 PROFILE

SCALE 1 inch = 50 feet Horiz.  
1 inch = 5 feet Vert.

NO.	DATE	DESCRIPTION

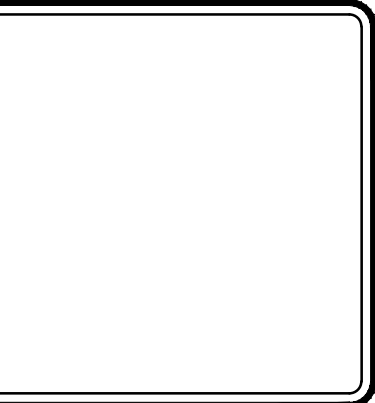

PHASE I-VII  
**LEEMAN FIELD GREENWAY**  
Pennington Gap, Virginia



Engineering - Surveying

KENTUCKY  
606-248-6600

TENNESSEE  
865-546-5800

NORTH CAROLINA  
828-253-2796

SOUTH CAROLINA  
864-574-4775

www.vaughnmelton.com

Copyright © 2012  
All Rights Reserved

DRAWN:	R.C.D.
CHECKED:	A.T.M.
JOB NO:	51120-55
SCALE:	1"=50'
DATE:	----
FILE NAME:	51120-55_Proposed Layout.dwg
DRAWING TITLE:	TRAIL NO. 3 PLAN AND PROFILE STA. 90+00 TO STA. 93+41.94

SHEET	DRAWING NO.
----	----
OF	<b>C8.0</b>



3/13/2012

T:\Civil\51120-55\Data\Drawings\51120-55\_Proposed\_Layout.dwg

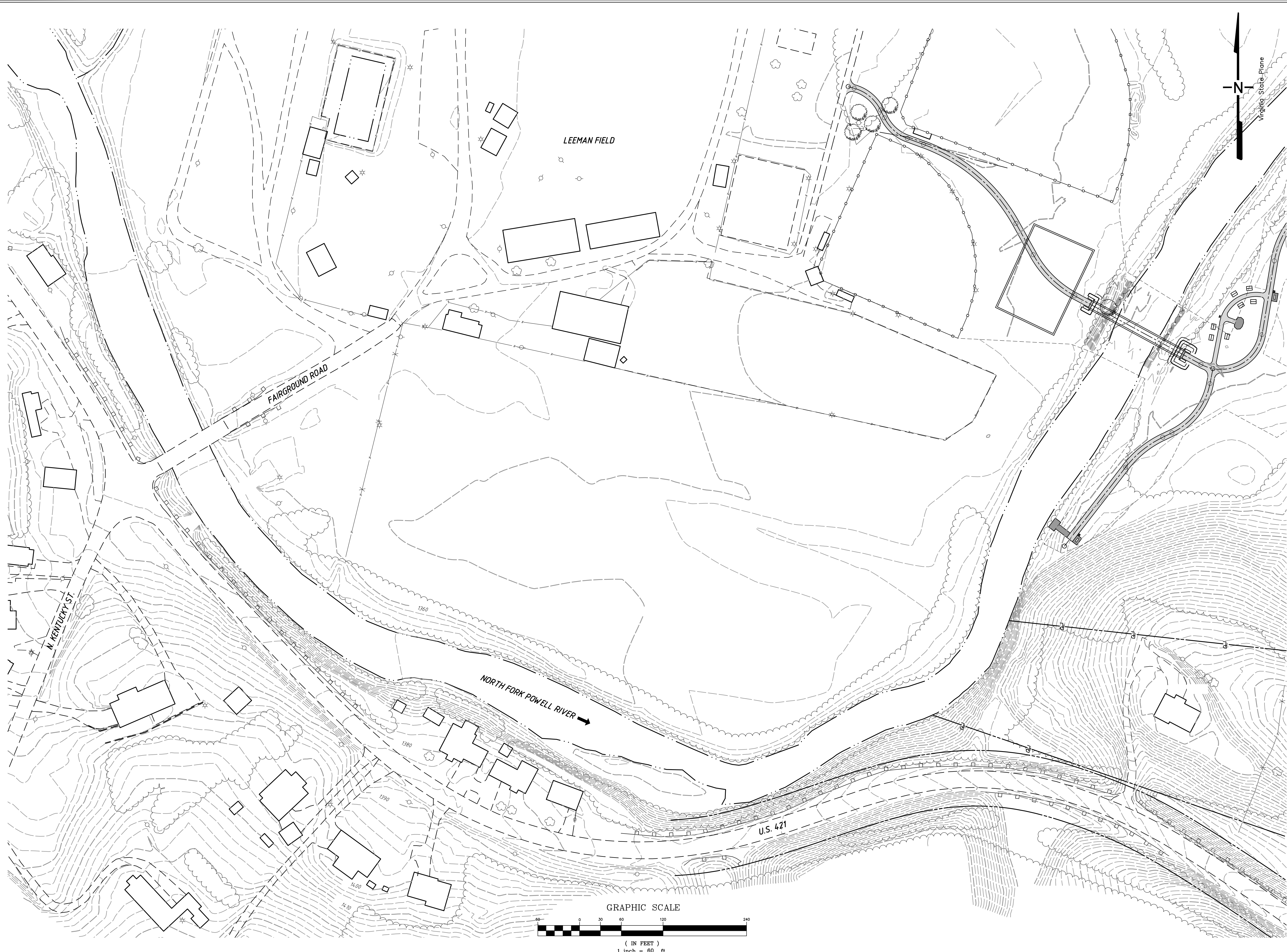

NO.	DATE	DESCRIPTION

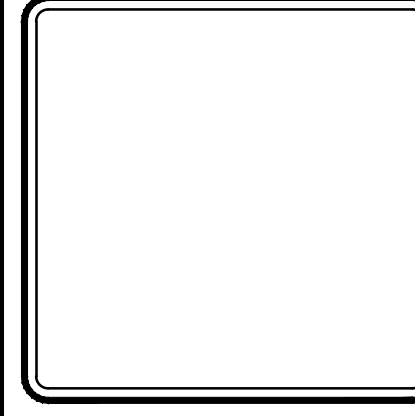

**PHASE I-VII**  
**LEEMAN FIELD GREENWAY**  
 Pennington Gap, Virginia

**V&M**  
**Vaughn & Melton**  
 Engineering - Surveying  
 KENTUCKY  
 606-248-6600  
 TENNESSEE  
 865-546-5800  
 NORTH CAROLINA  
 828-253-2796  
 SOUTH CAROLINA  
 864-574-4775  
 www.vaughnmelton.com  
 Copyright © 2012  
 All Rights Reserved

DRAWN:	R.C.D.
CHECKED:	A.T.M.
JOB NO:	51120-55
SCALE:	1" = 60'
DATE:	----
FILE NAME:	51120-55_Proposed_Layout.dwg
DRAWING TITLE:	GREENWAY LOCATION AT LEEMAN FIELD

SHEET	DRAWING NO.
----	----
OF	<b>C9.0</b>



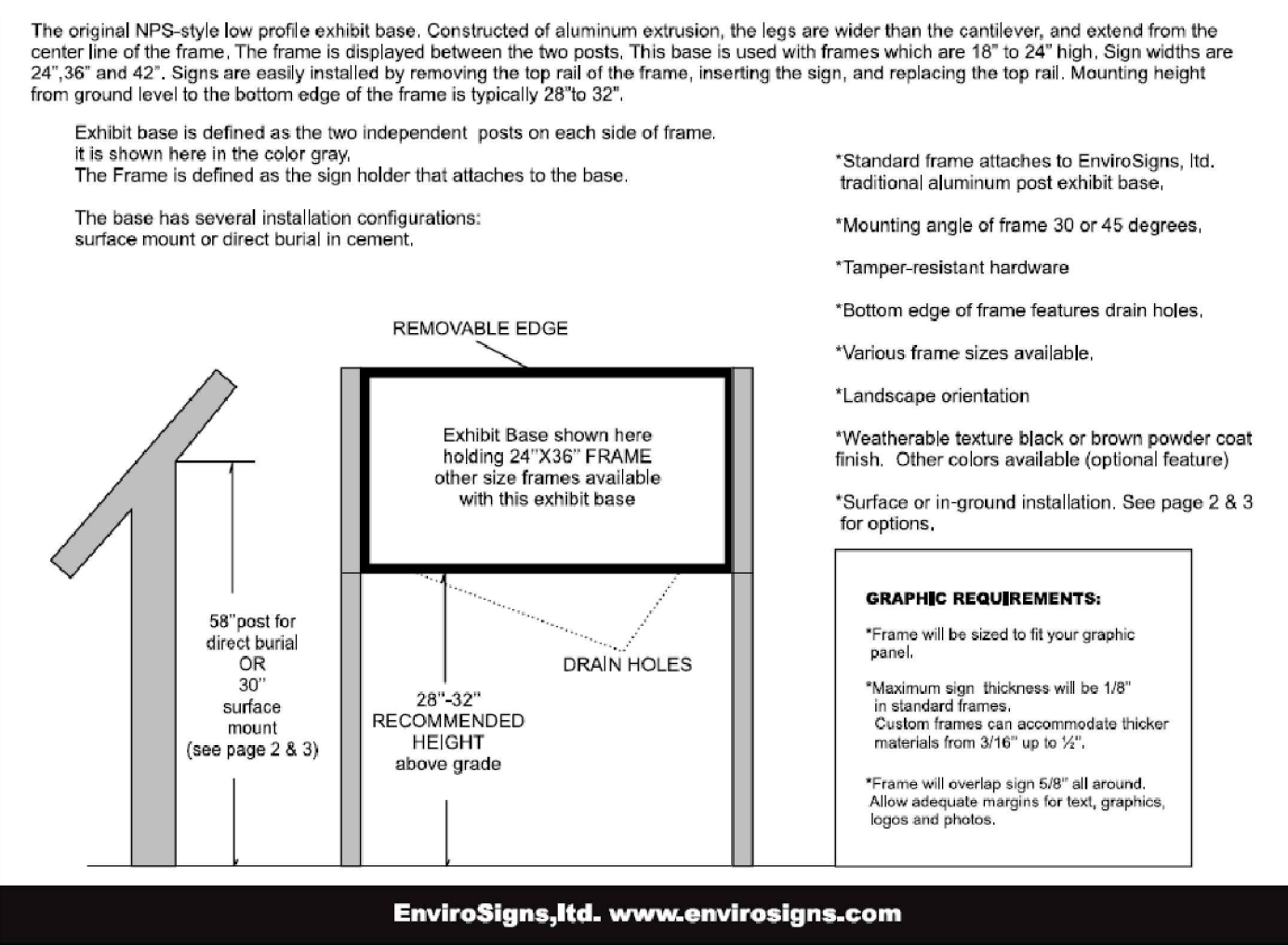
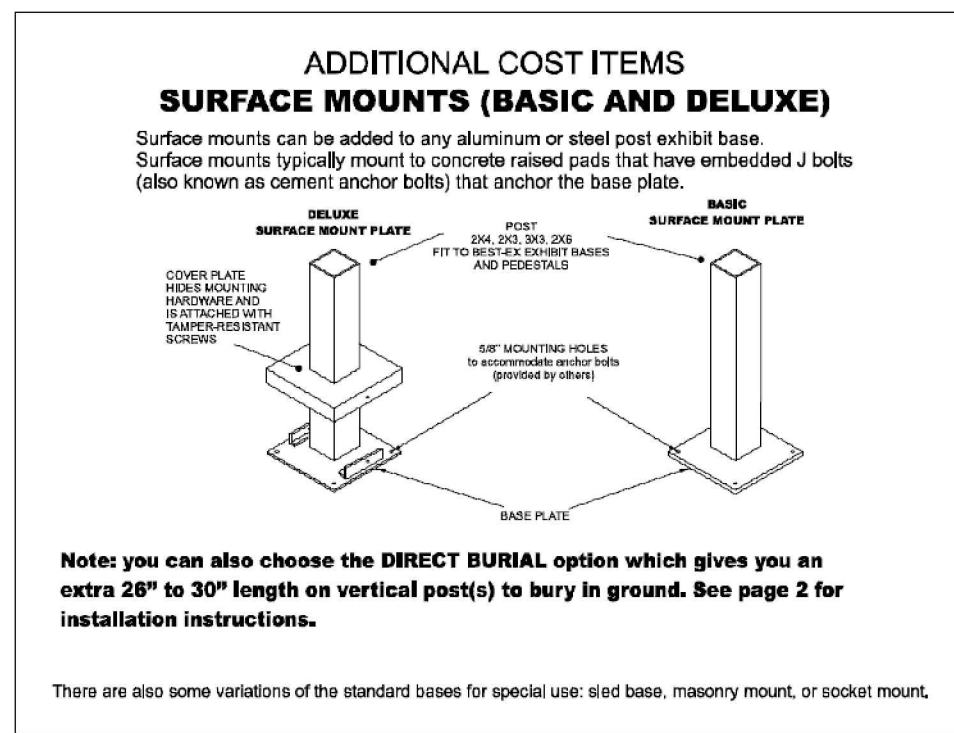

**TYPICAL INTERPRETIVE SIGN**  
 SEE PLAN AND PROFILE SHEETS FOR LOCATIONS

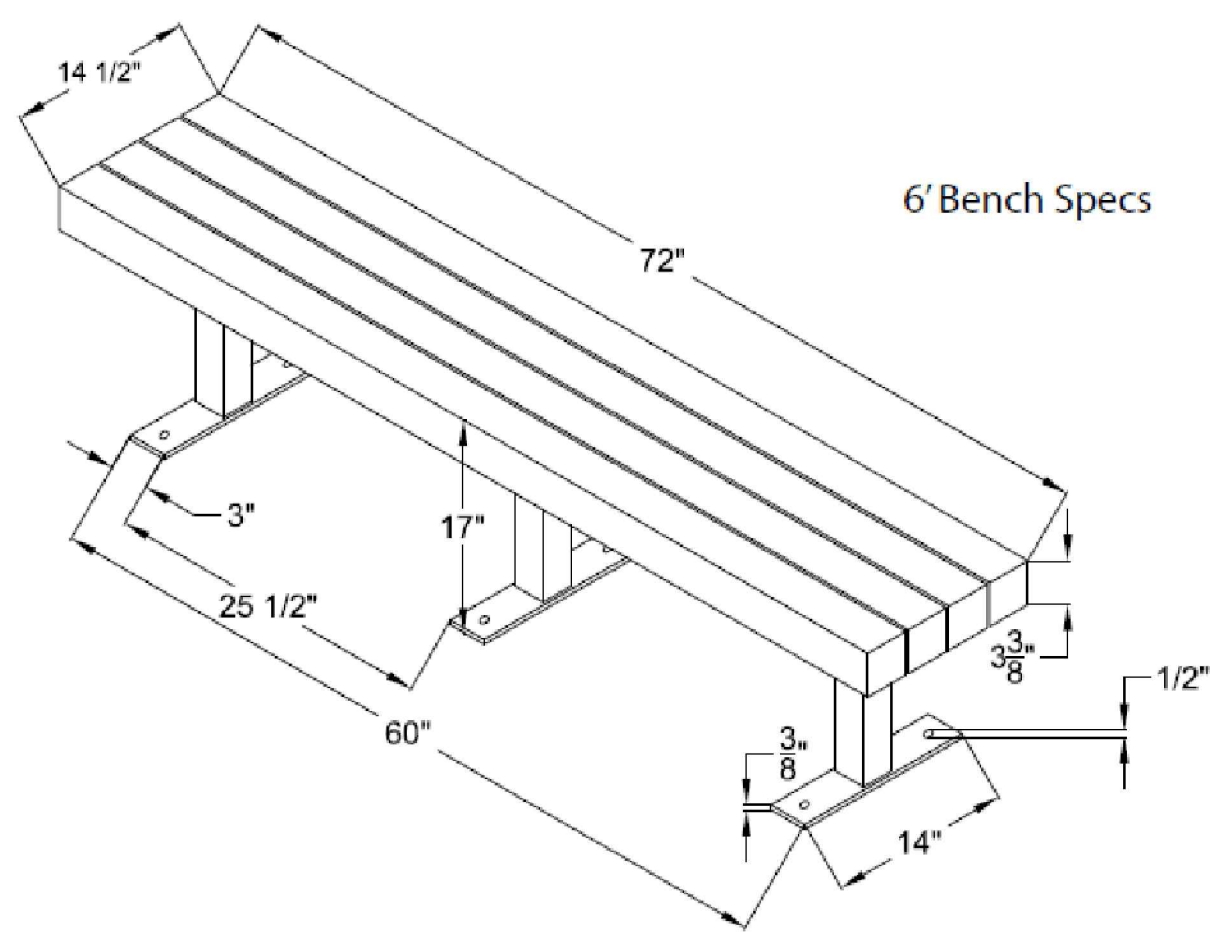

- "Backless and bold"**
- SEAT IS RECYCLED PLASTIC
  - HEAVY DUTY, POWDER-COATED STRUCTURAL STEEL FRAMES
  - FRAME INCLUDES HOLE FOR SURFACE MOUNT
  - COMES WITH ZINC COATED HARDWARE
  - STAINLESS STEEL HARDWARE AVAILABLE
  - UNIT WEIGHT APPROX. 145 LBS.

**TYPICAL TRAIL BENCH**  
 SEE PLAN AND PROFILE SHEETS FOR LOCATIONS



**TYPICAL TRASH RECPTICLE**  
 SEE PLAN AND PROFILE SHEETS FOR LOCATIONS



**TYPICAL GAZEBO STRUCTURE**  
 SEE PLAN AND PROFILE SHEETS FOR LOCATIONS

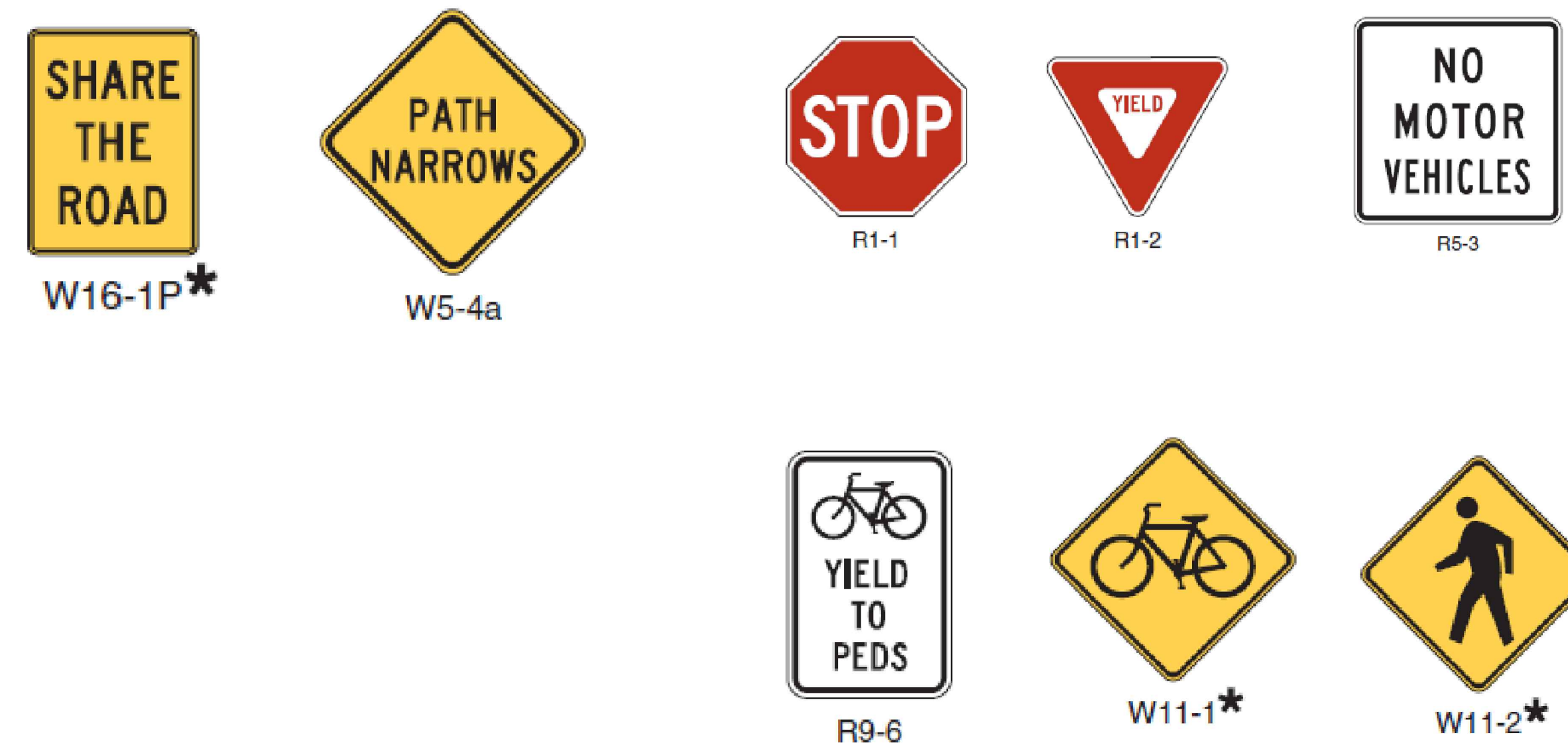

**TRAIL AND PARKING LOT SIGNS**  
 SEE PLAN AND PROFILE SHEETS FOR LOCATIONS

NO.	DATE	REVISIONS DESCRIPTION

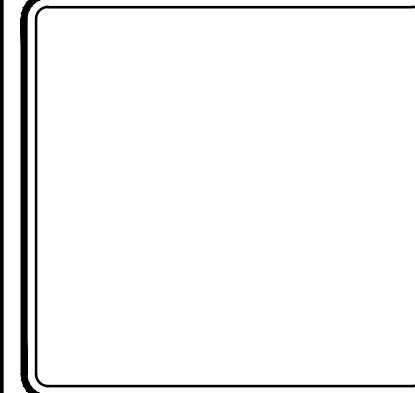

**PHASE I-VII**  
**LEEMAN FIELD GREENWAY**  
 Pennington Gap, Virginia

**V&M**  
**Vaughn & Melton**  
 Engineering - Surveying

KENTUCKY  
606-248-6600

TENNESSEE  
865-546-5800

NORTH CAROLINA  
828-253-2796

SOUTH CAROLINA  
864-574-4775

www.vaughnmelton.com  
 Copyright ©2012  
 All Rights Reserved

DRAWN:	R.C.D.
CHECKED:	A.T.W.
JOB NO:	51120-55
SCALE:	N/A
DATE:	?
FILE NAME:	SEE PLOT STAMP
DRAWING TITLE:	CONSTRUCTION DETAILS
SHEET ? OF ?	DRAWING NO: D1.0



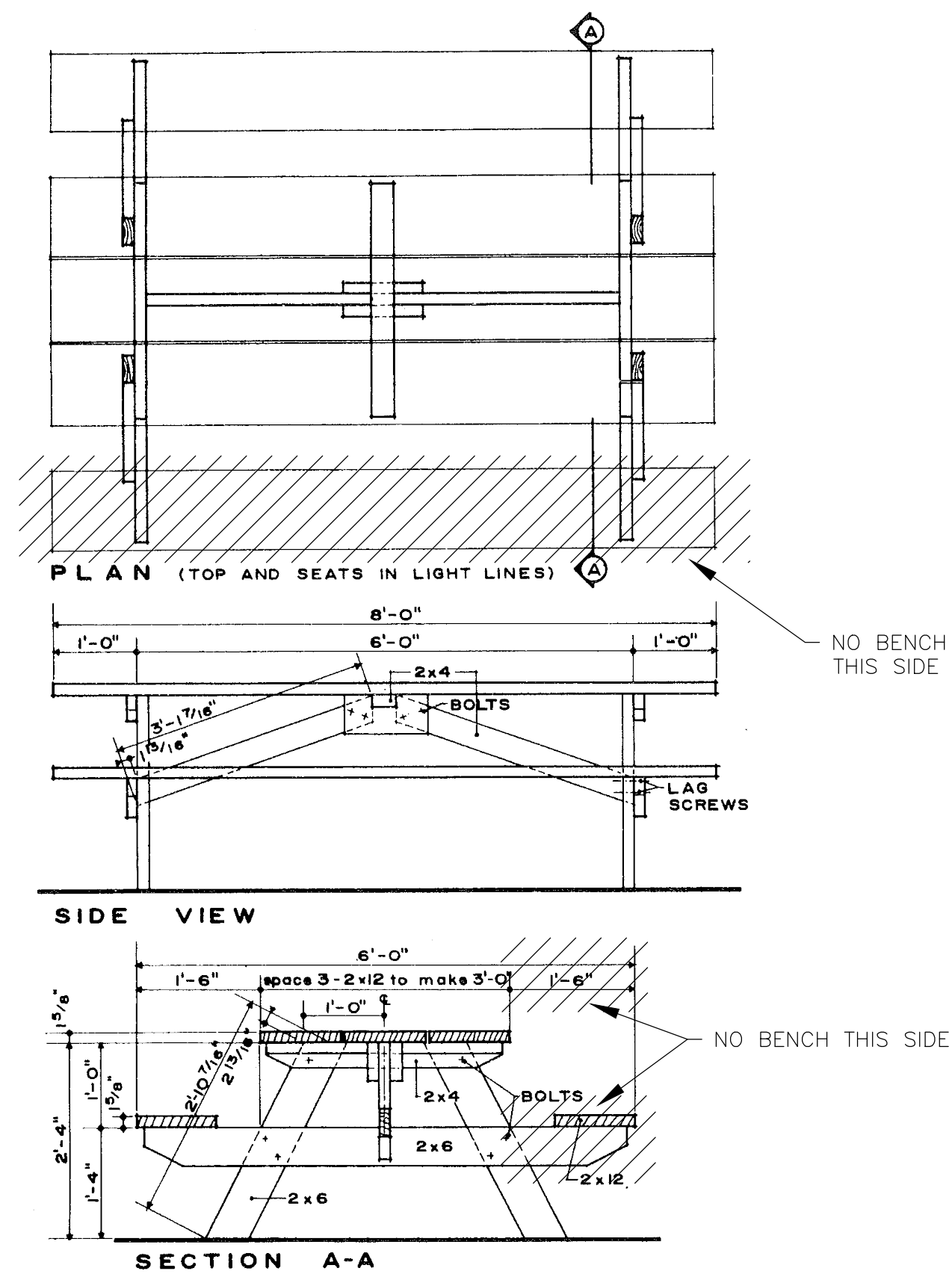

**HANDICAPPED PICNIC TABLE DETAIL**  
NOT TO SCALE

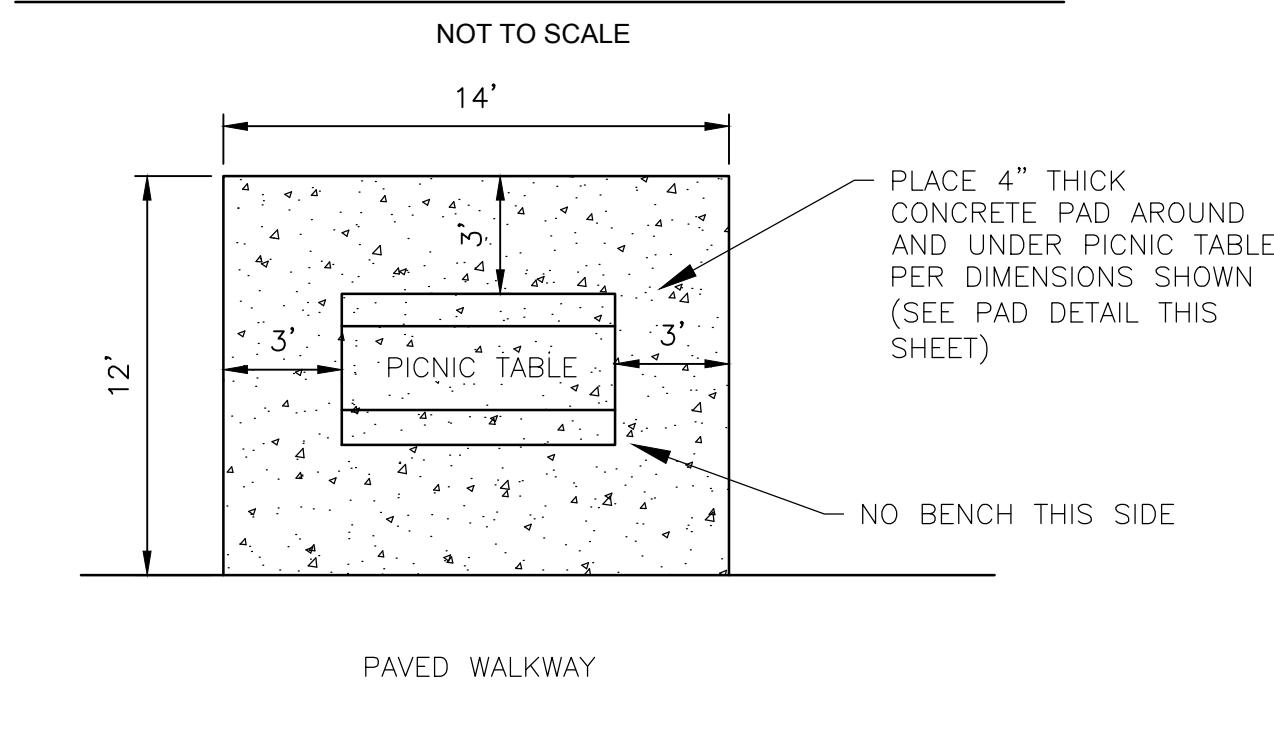

**HANDICAPPED PICNIC TABLE LOCATION DETAIL**  
SEE PLAN AND PROFILE SHEETS FOR LOCATIONS  
NOT TO SCALE

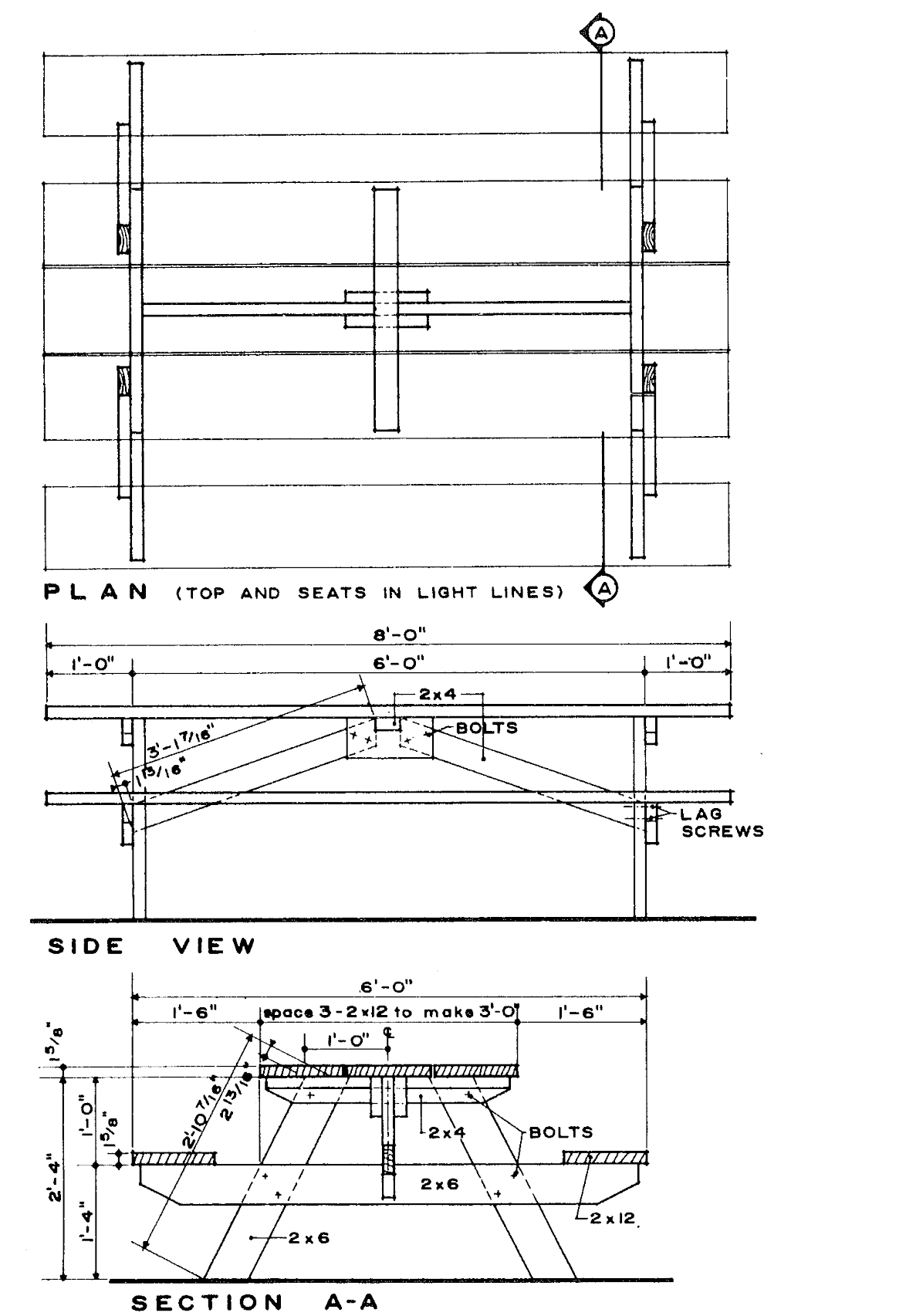

**TYPICAL PICNIC TABLE DETAIL**  
NOT TO SCALE

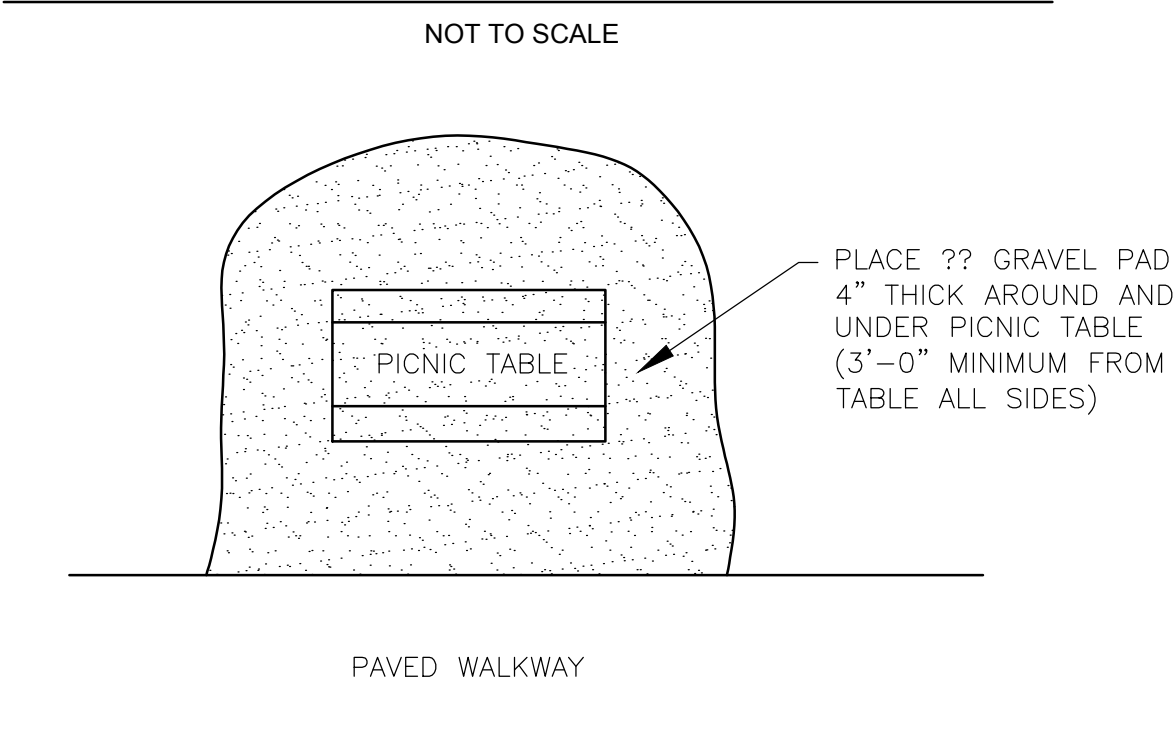

**TYPICAL PICNIC TABLE LOCATION DETAIL**  
SEE PLAN AND PROFILE SHEETS FOR LOCATIONS  
NOT TO SCALE

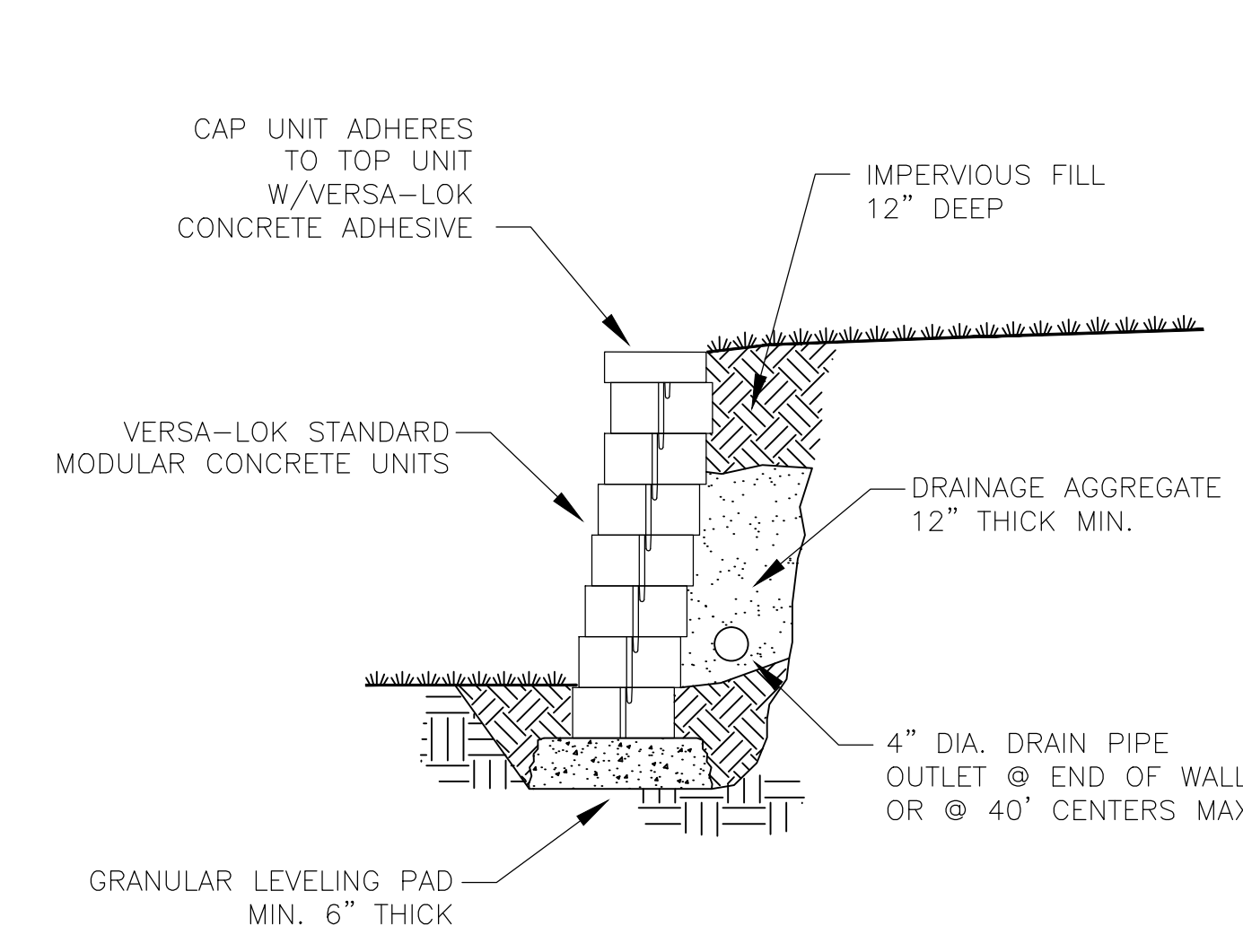

**VERSA-LOCK (OR EQUAL) TYPICAL SECTION - UNREINFORCED RETAINING WALL**  
SEE PLAN AND PROFILE SHEETS FOR LOCATIONS  
NOT TO SCALE

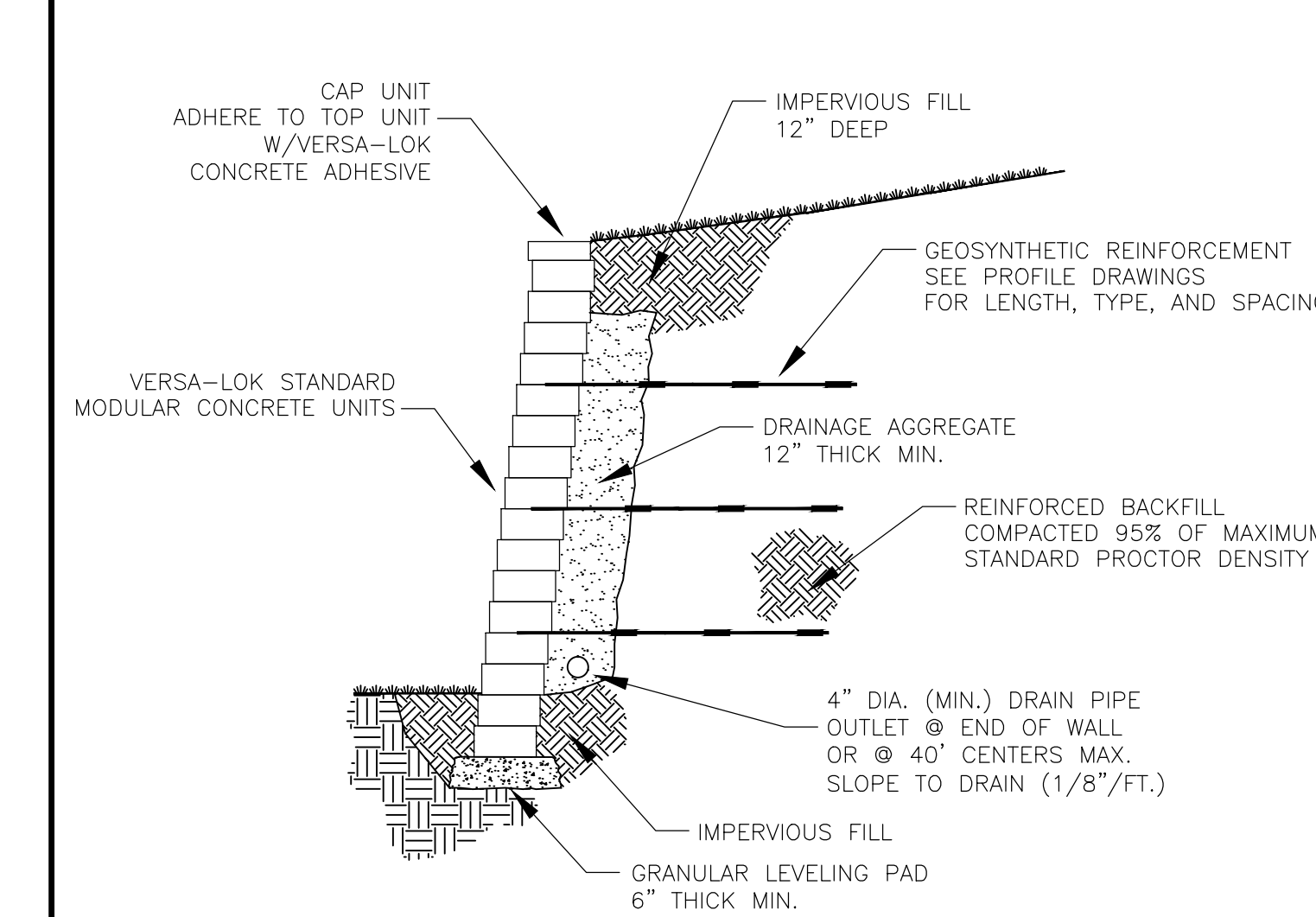

**VERSA-LOCK (OR EQUAL) TYPICAL SECTION - REINFORCED RETAINING WALL**  
SEE PLAN AND PROFILE SHEETS FOR LOCATIONS  
NOT TO SCALE

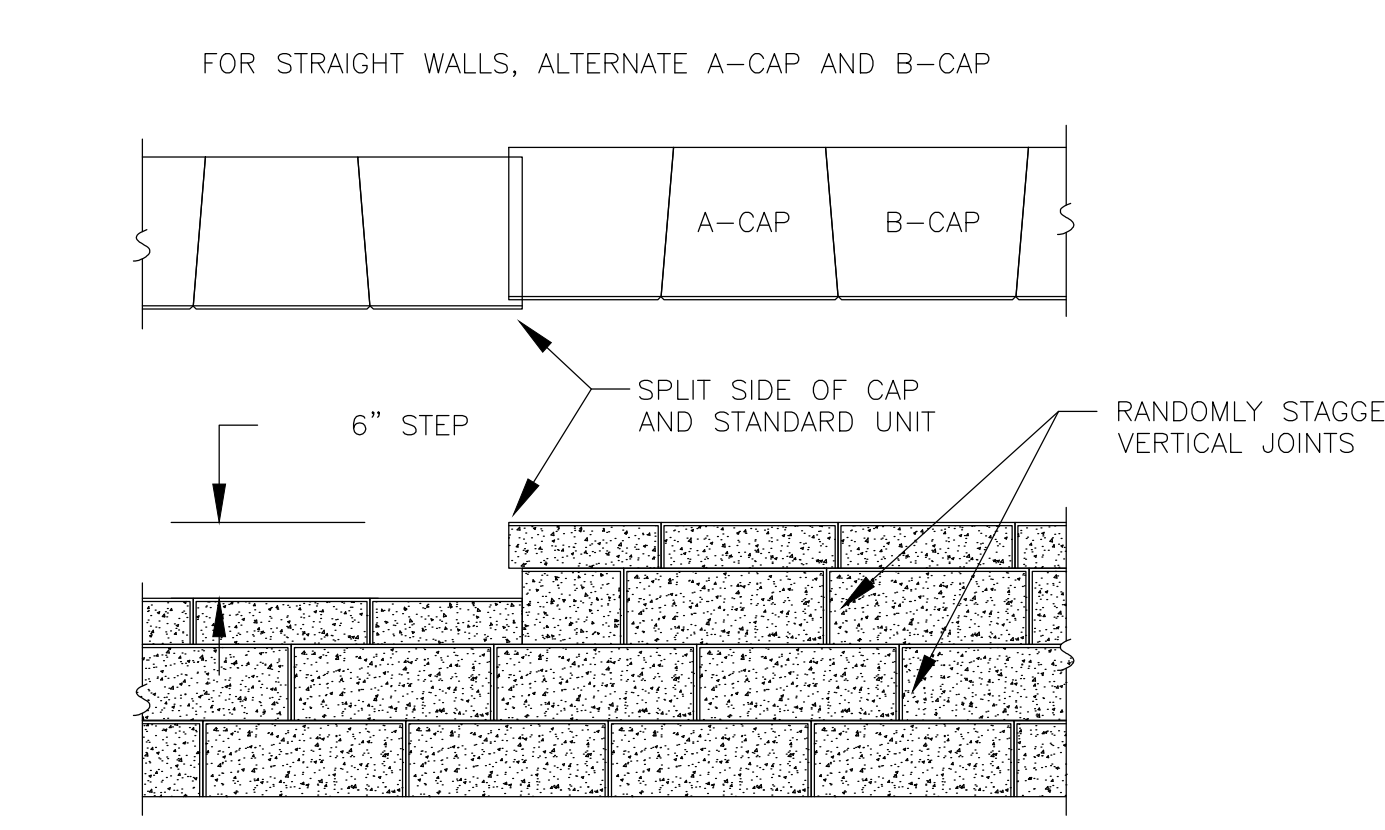

**VERSA-LOCK CAPPING DETAIL - PROFILE (OR EQUAL)**  
SEE PLAN AND PROFILE SHEETS FOR LOCATIONS  
NOT TO SCALE

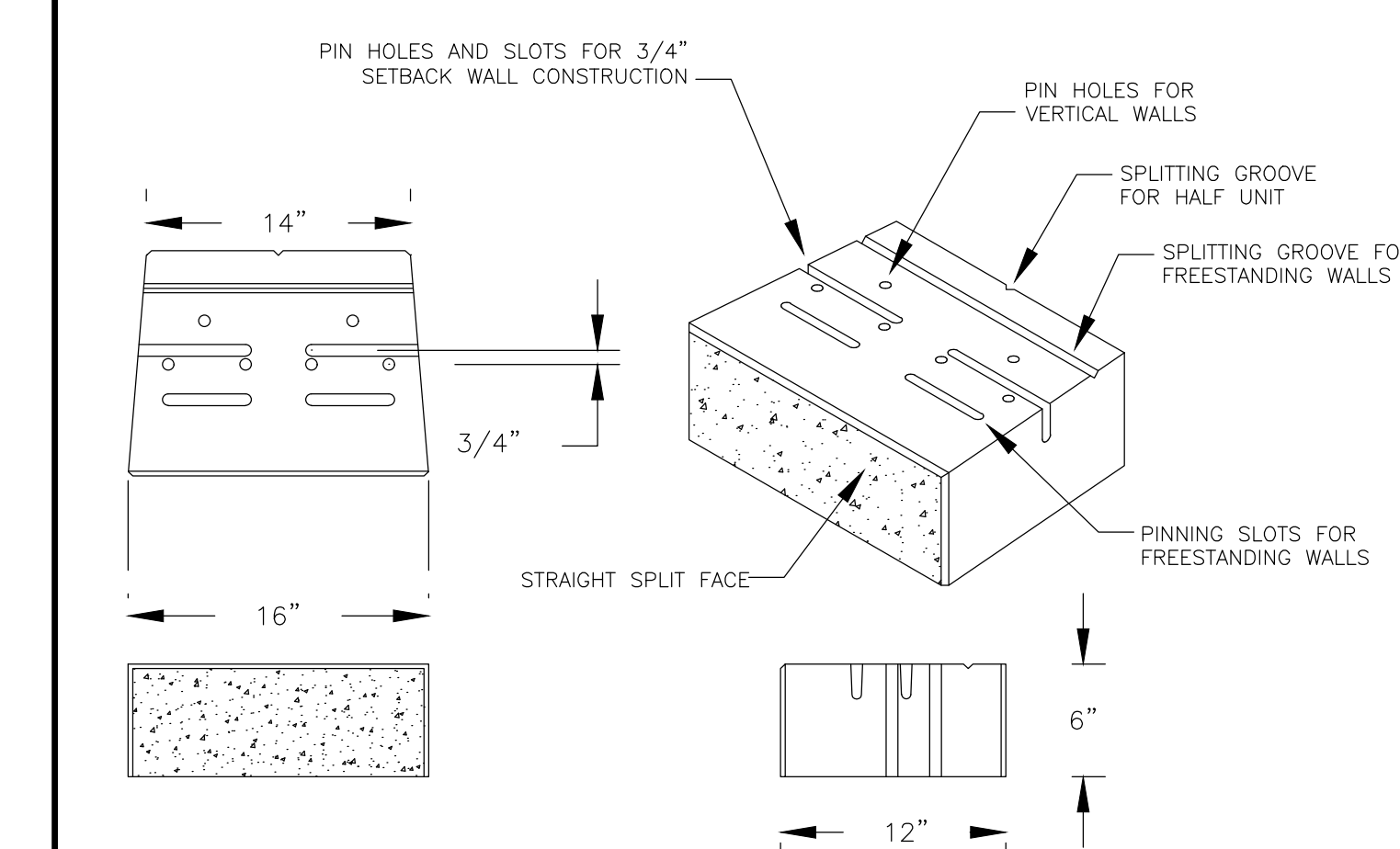

**VERSA-LOCK MODULAR BLOCK UNIT (OR EQUAL)**  
SEE PLAN AND PROFILE SHEETS FOR LOCATIONS  
NOT TO SCALE

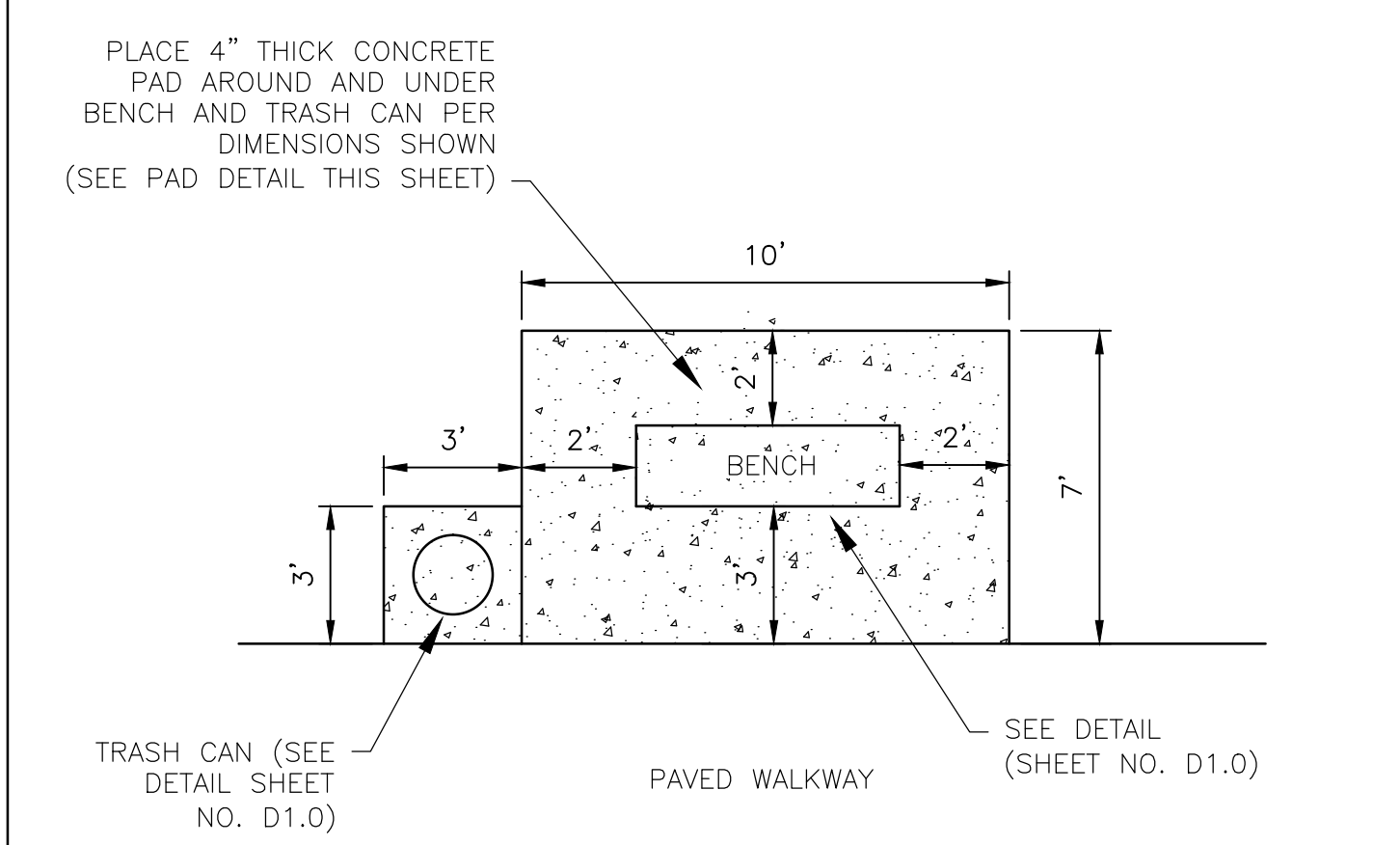

**BENCH AND TRASH CAN DETAIL**  
SEE PLAN AND PROFILE SHEETS FOR LOCATIONS  
NOT TO SCALE

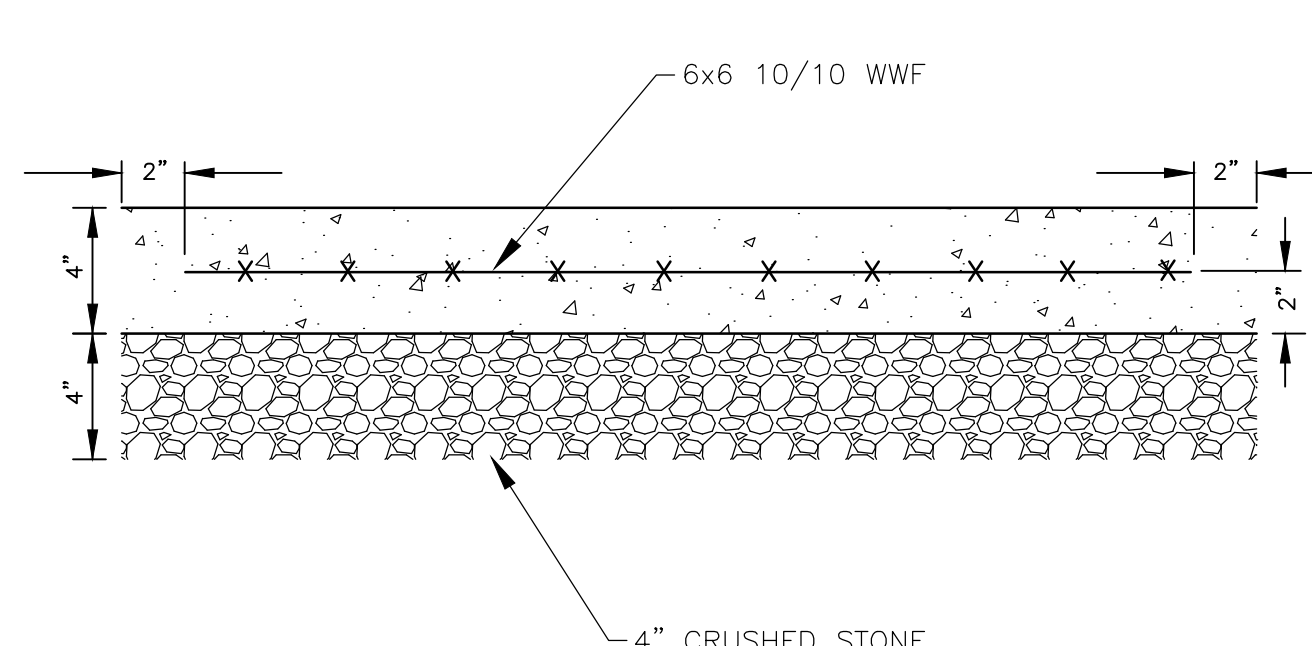

- NOTES:**
1. CONCRETE TO BE 3000 PSI
  2. SAW JOINT OR CONSTRUCTION JOINT ON LENGTHS OVER 6'-0"
  3. MINIMUM THICKNESS 4"
  4. PROVIDE EXPANSION JOINTS AT INTERSECTIONS OF PAD WITH OTHER STRUCTURES UNLESS NOTED OTHERWISE

**CONCRETE PAD DETAIL**  
NOT TO SCALE

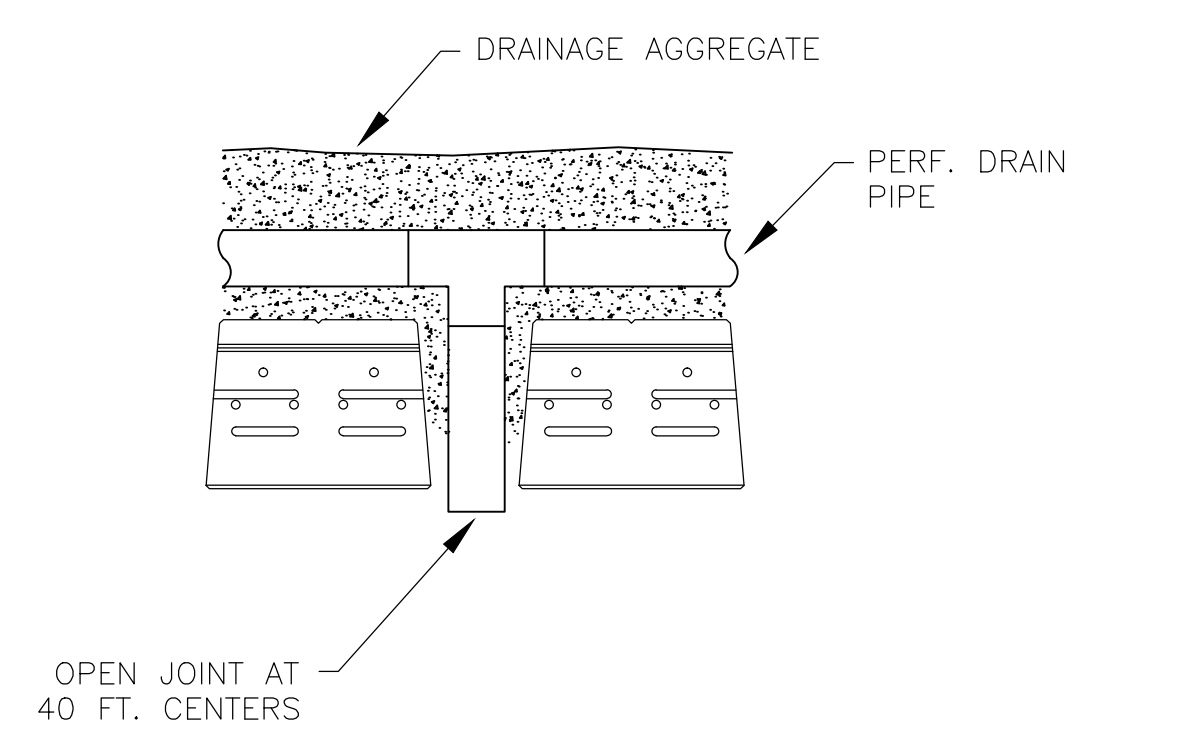

**RETAINING WALL DRAIN DETAIL**  
NOT TO SCALE

NO.	DATE	DESCRIPTION

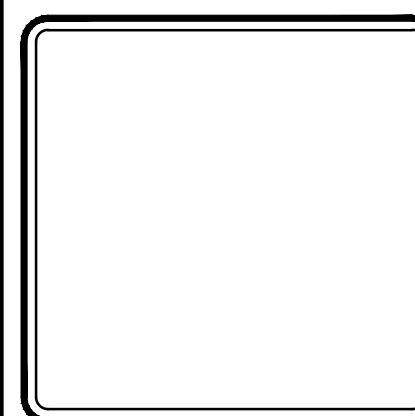

**PHASE I-VII**  
**LEEMAN FIELD GREENWAY**  
Pennington Gap, Virginia

**V&M**  
**Vaughn & Melton**  
Engineering - Surveying  
KENTUCKY  
606-248-6600  
TENNESSEE  
865-546-5800  
NORTH CAROLINA  
828-253-2796  
SOUTH CAROLINA  
864-574-4775  
www.vaughnmelton.com  
Copyright ©2012  
All Rights Reserved

DRAWN:	R.C.D.
CHECKED:	A.T.W.
JOB NO.:	51120-55
SCALE:	N/A
DATE:	10 FEB 2012
FILE NAME:	SEE PLOT STAMP
DRAWING TITLE:	CONSTRUCTION DETAILS
SHEET	DRAWING NO.:
?	?
OF	<b>D2.0</b>
?	?





DETAIL LIBRARY  
 VIRGINIA DEPARTMENT OF  
 GAME & INLAND FISHERIES  
 OFFICE OF CAPITAL PROGRAMS  
 4010 WEST BROAD STREET  
 RICHMOND, VA 23230-1104  
 TELEPHONE: (804) 367-9587  
 FAX: (804)367-9147

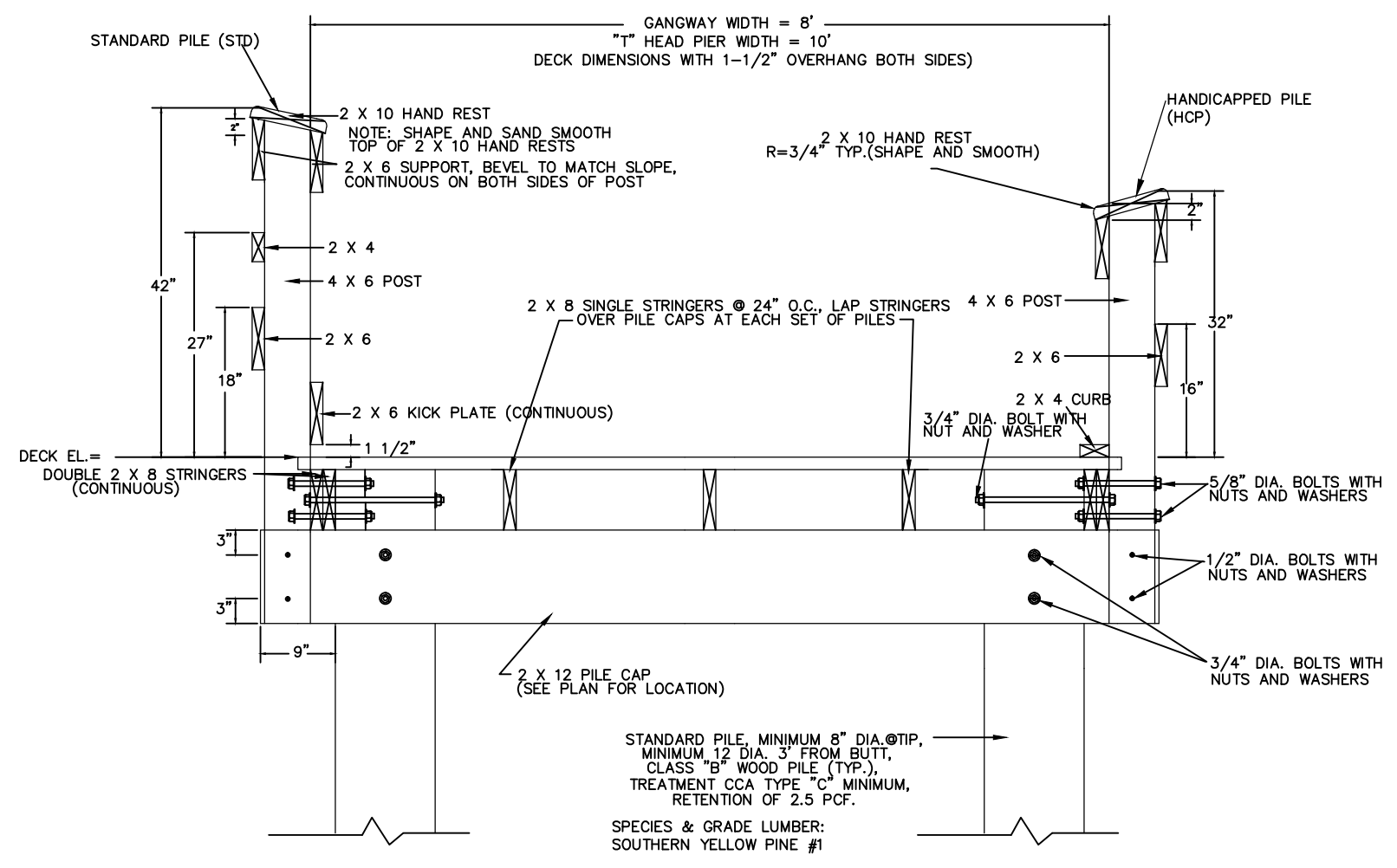

UHANDICAPPED FISHING PIER

**FISHING PIER TYPICAL DETAILS**  
 SEE PLAN AND PROFILE SHEETS FOR LOCATIONS  
 NOT TO SCALE

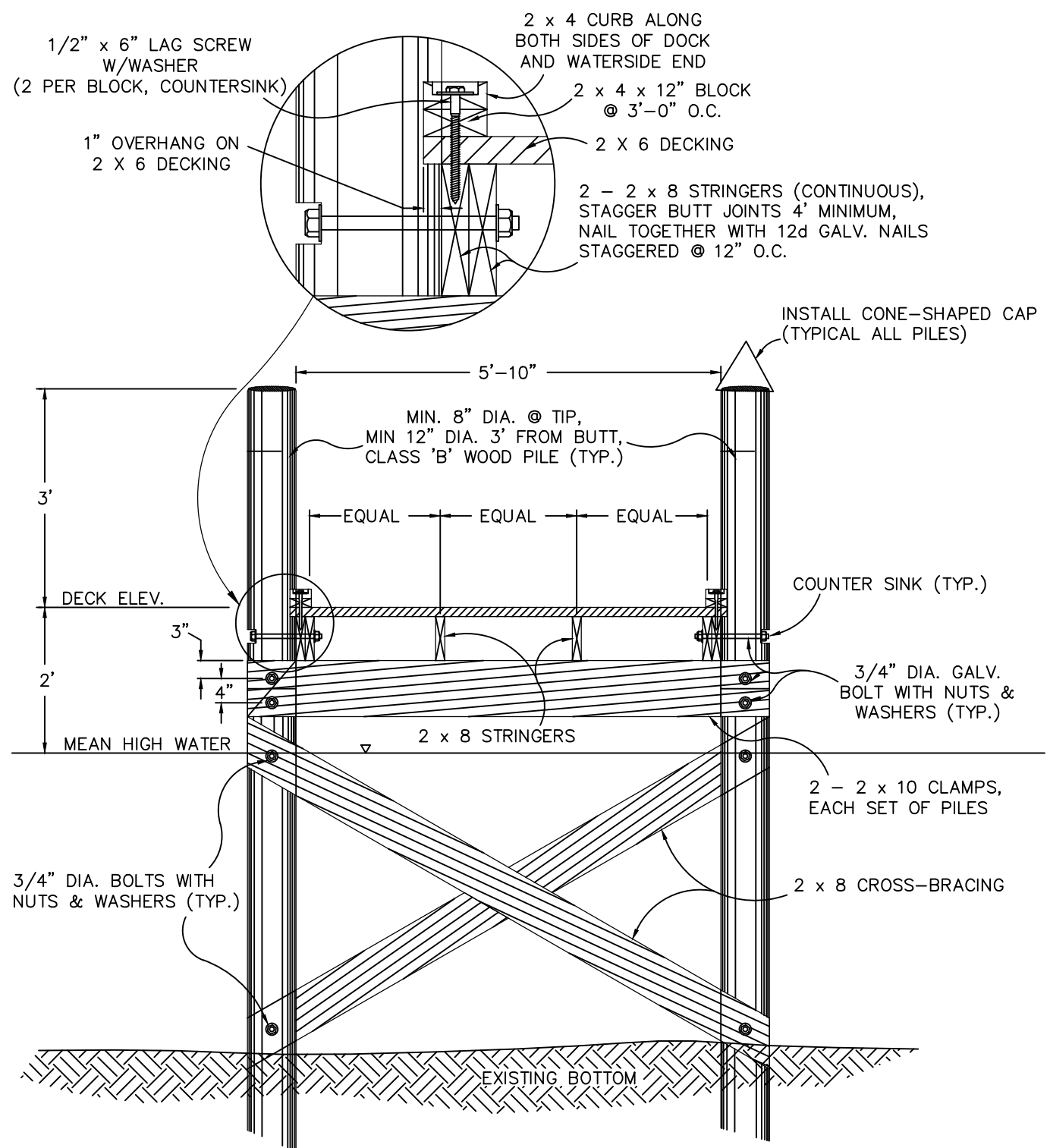

DECKING & FRAMING

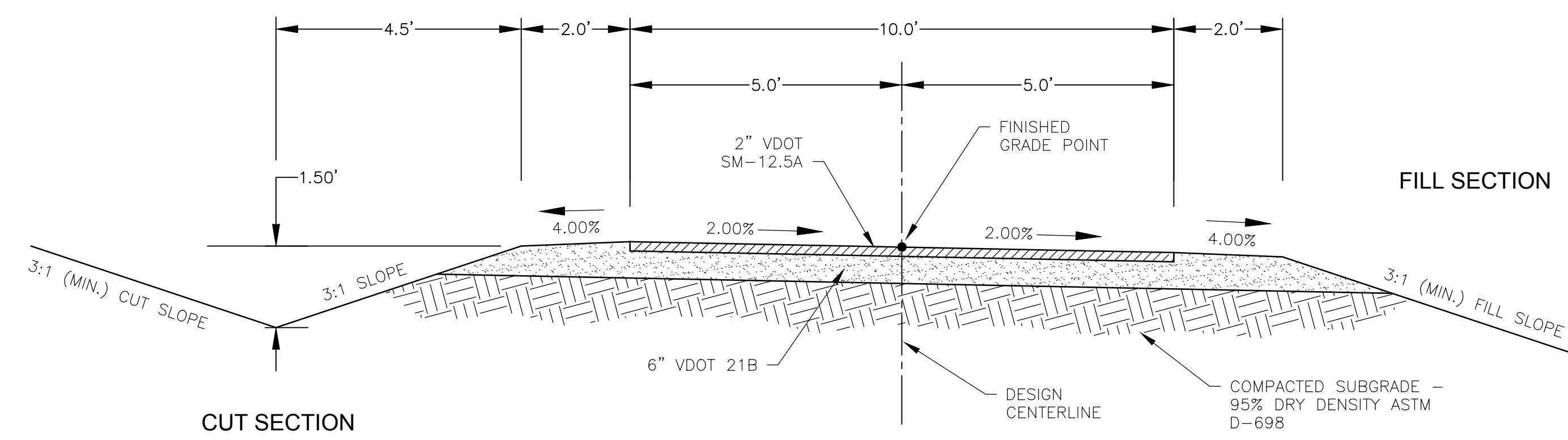

CUT SECTION

**GREENWAY TYPICAL SECTION ( 10' WIDTH )**

SEE PLAN AND PROFILE SHEETS FOR LOCATIONS  
 NOT TO SCALE

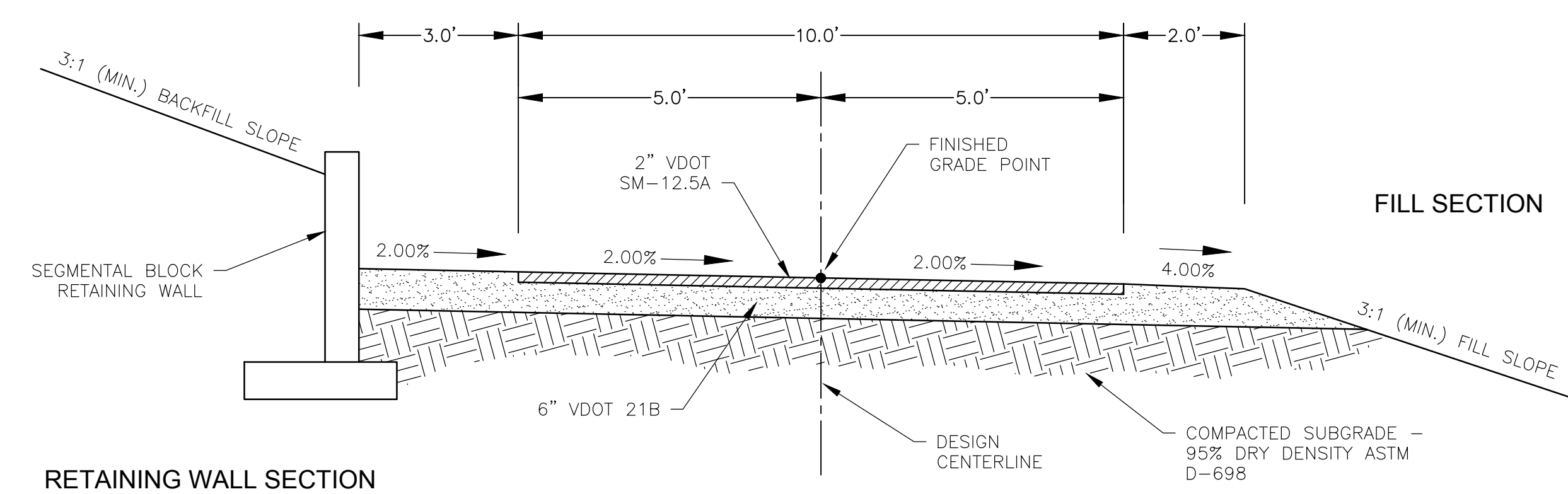

RETAINING WALL SECTION

**GREENWAY TYPICAL SECTION ( 10' WIDTH )**

WITH RETAINING WALL  
 STA. 18+45 TO STA. 20+30  
 NOT TO SCALE

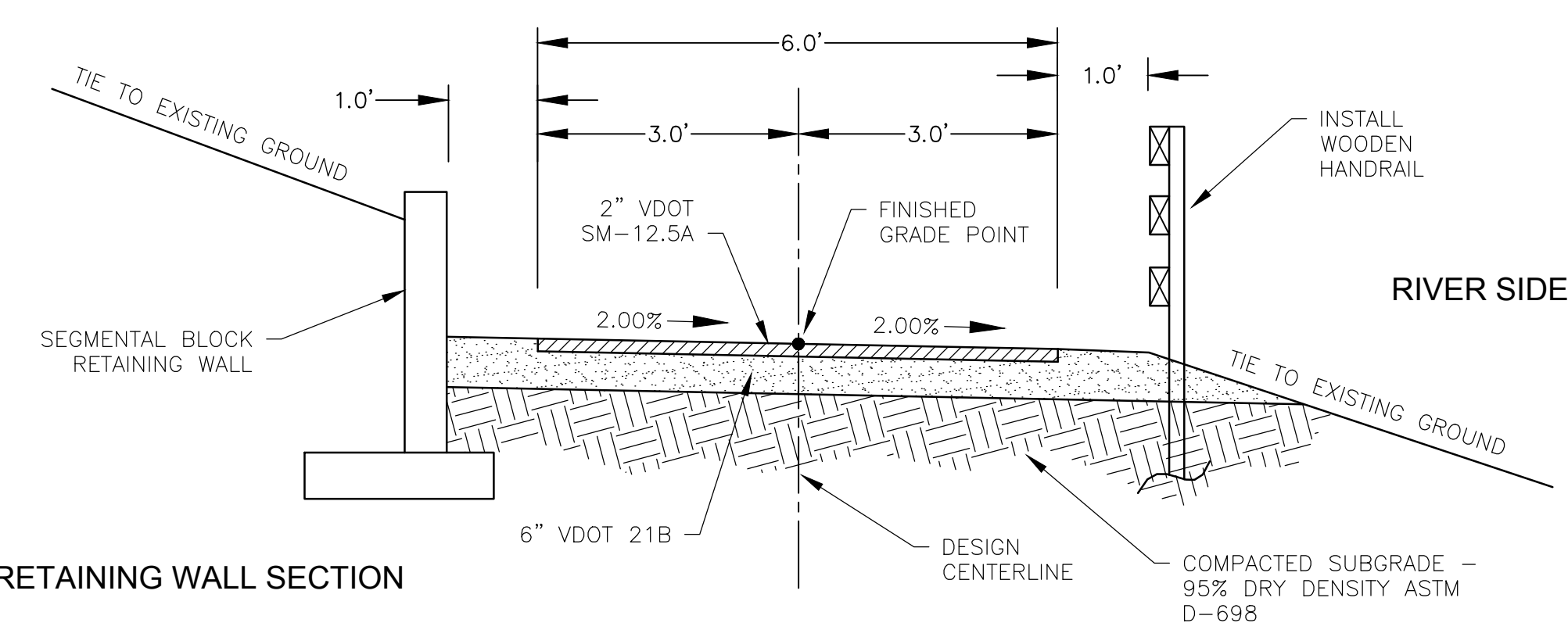

RETAINING WALL SECTION

**GREENWAY TYPICAL SECTION ( 6' WIDTH )**

WITH RETAINING WALL  
 STA. 55+00 TO STA. 59+00  
 NOT TO SCALE

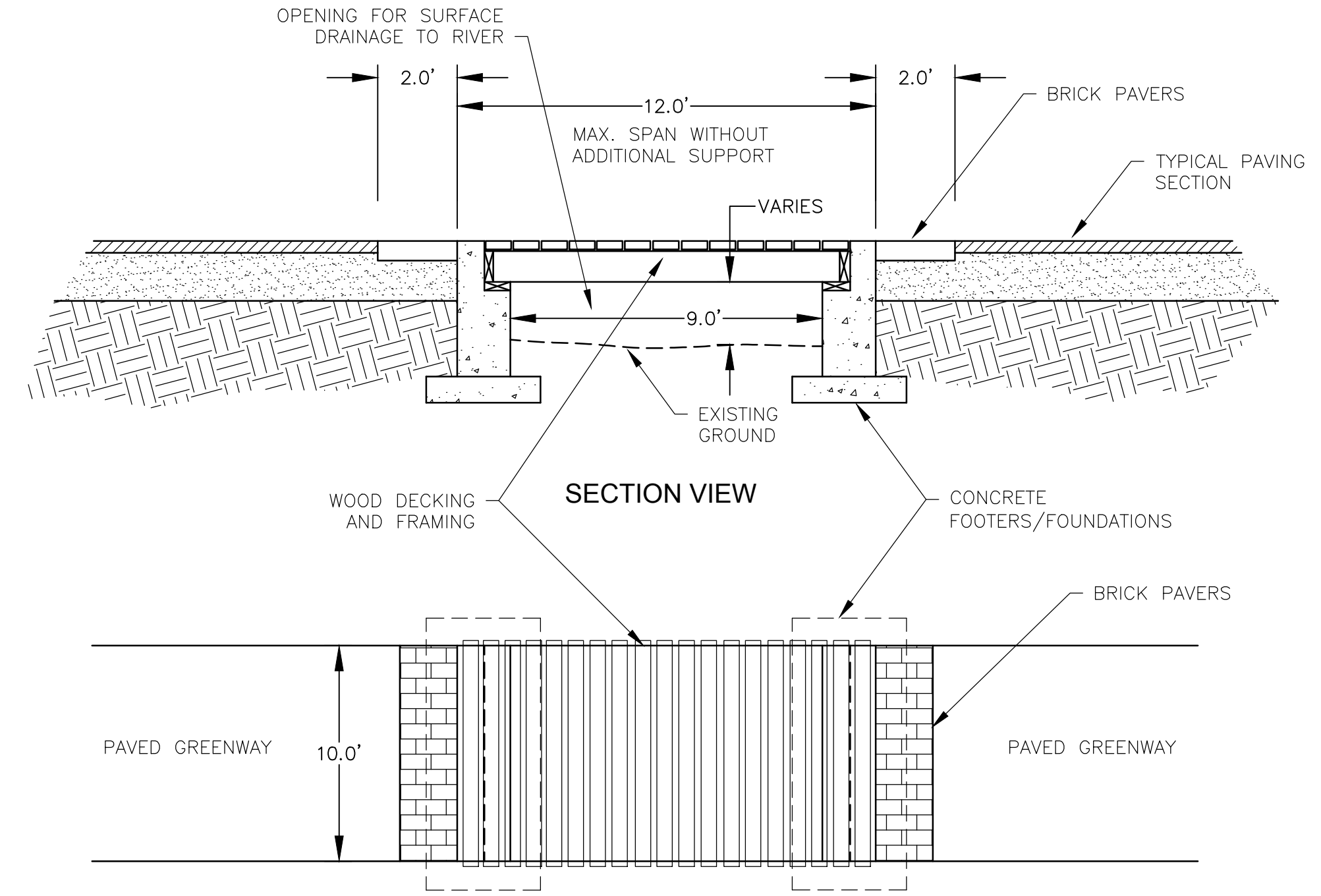

SECTION VIEW

PLAN VIEW

**GREENWAY TYPICAL DRAINAGE CROSS-THRU DETAIL**

SEE PLAN AND PROFILE SHEETS FOR LOCATIONS  
 NOT TO SCALE



**CONCEPTUAL DESIGN OF BOARDWALK**

SEE PLAN AND PROFILE SHEETS FOR LOCATIONS  
 NOT TO SCALE

NO.	DATE	DESCRIPTION

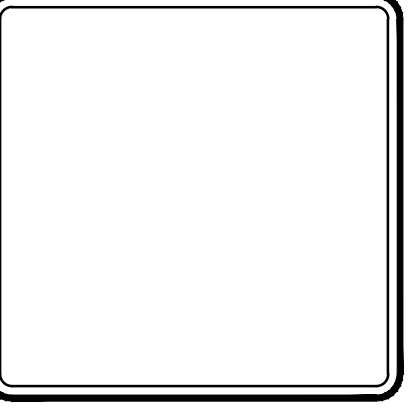

**PHASE I-VII**  
**LEEMAN FIELD GREENWAY**  
 Pennington Gap, Virginia

**V&M**  
**Vaughn & Melton**  
 Engineering - Surveying  
 KENTUCKY  
 606-248-6600  
 TENNESSEE  
 865-546-5800  
 NORTH CAROLINA  
 828-253-2796  
 SOUTH CAROLINA  
 864-574-4775  
 www.vaughnmelton.com  
 Copyright ©2012  
 All Rights Reserved

DRAWN:	R.C.D.
CHECKED:	A.T.W.
JOB NO.:	51120-55
SCALE:	N/A
DATE:	?
FILE NAME:	SEE PLOT STAMP
DRAWING TITLE:	CONSTRUCTION DETAILS

SHEET	DRAWING NO.:
?	D3.0
OF	
?	





# **LENOWISCO Planning District 2021 Hazard Mitigation Plan**





1	<b>Contents</b>	
2	Section 1.1 Executive Summary .....	8
3	Section 1.2 Introduction .....	9
4	Emergency Management Background .....	9
5	Hazard Mitigation Background .....	10
6	Plan Description.....	10
7	Plan Purpose .....	11
8	Section 1.3 Prerequisites .....	12
9	1.3.1 Plan Adoption .....	13
10	1.3.2 Planning Teams & Jurisdiction Participation .....	15
11	Participating Jurisdictions.....	16
12	1.3.3 Plan Authority .....	17
13	Hazard Mitigation Legislation .....	17
14	Hazard Mitigation Grant Program.....	18
15	Pre-Disaster Mitigation Program .....	19
16	Section 1.4 Planning Process .....	20
17	Purpose .....	20
18	Scope .....	20
19	Mission Statement .....	20
20	Federal and State Plan Compliance and Integration .....	21
21	Plan Use .....	21
22	Hazard Mitigation .....	21
23	1.4.1 Existing Plans and Technical and Fiscal Resource Review .....	22
24	1.4.2 Plan Participation.....	24
25	Planning Process Detailed .....	24
26	Planning Team Meetings .....	26
27	Non-Participating Jurisdictions .....	34
28	Community Preparedness Survey.....	35
29	Public Forums and Outreach.....	39
30	Public Plan Review and Feedback.....	40
31	Section 1.5 Community Profile .....	41
32	1.5.1 Topography, Geography, and Geology .....	41
33	1.5.2 Climate .....	45
34	1.5.3 Demographics .....	47
35	Population.....	47



1	Age .....	48
2	Educational Attainment .....	49
3	Race/Ethnicity .....	50
4	Commuting Patterns .....	50
5	Poverty .....	51
6	Additional Data .....	52
7	1.5.4 Economy .....	53
8	Unemployment Rates.....	53
9	Local Employers and Industry.....	55
10	Income and Wages .....	56
11	1.5.5 Critical Facilities.....	57
12	Lee County .....	58
13	Scott County .....	60
14	Wise County .....	62
15	1.5.6 Capability Assessment .....	65
16	1.5.7 Land Use and Future Development .....	68
17	Lee County Land Use and Future Development.....	69
18	Scott County Land Use and Future Development .....	70
19	Wise County Land Use and Future Development.....	72
20	City of Norton Land Use and Future Development.....	75
21	Section 1.6 Risk Assessment Overview .....	76
22	1.6.1 Communicable Disease.....	76
23	COVID-19 .....	76
24	Hazard Extent .....	78
25	History/Previous Occurrences.....	78
26	Future Probability.....	82
27	Geographic Location.....	83
28	Loss Estimates .....	83
29	Vulnerability and Community Development Analysis.....	83
30	Hazard Evaluation and Impact/Consequence Assessment .....	88
31	1.6.2 Dam Failure.....	89
32	Hazard Extent .....	91
33	History/Previous Occurrences.....	91
34	Future Probability.....	92
35	Geographic Location.....	92





1	Loss Estimates .....	97
2	Vulnerability and Community Development Analysis.....	97
3	Hazard Evaluation and Impact/Consequence Assessment .....	98
4	1.6.3 Drought.....	99
5	Hazard Extent .....	100
6	History/Previous Occurrences.....	102
7	Future Probability.....	104
8	Geographic Location.....	105
9	Loss Estimates .....	106
10	Vulnerability & Community Development Analysis.....	107
11	Hazard Evaluation and Impact/Consequence Assessment .....	110
12	1.6.4 Earthquake .....	111
13	Hazard Extent.....	112
14	History/Previous Occurrences.....	114
15	Future Probability.....	115
16	Geographic Location.....	117
17	Loss Estimates .....	118
18	Vulnerability and Community Development Analysis.....	119
19	HAZUS Earthquake Probability Analysis Loss Estimates .....	122
20	Hazard Evaluation and Impact/Consequence Assessment .....	128
21	1.6.5 Flooding.....	129
22	Hazard Extent.....	131
23	NFIP Participation .....	131
24	History/Previous Occurrences.....	132
25	Future Probability.....	137
26	Geographic Location.....	138
27	Loss Estimates .....	139
28	Vulnerability & Community Development Analysis for Flooding Hazard .....	141
29	Hazard Evaluation and Impact/Consequence Assessment .....	145
30	1.6.6 Karst & Subsidence .....	146
31	Hazard Extent.....	146
32	History/Previous Occurrences.....	146
33	Future Probability.....	147
34	Geographic Location.....	148
35	Loss Estimates .....	149



1	Vulnerability and Community Development Analysis.....	149
2	Hazard Evaluation and Impact/Consequence Assessment .....	151
3	1.6.7 Landslide .....	152
4	Hazard Extent .....	153
5	History/Previous Occurrences.....	153
6	Future Probability.....	154
7	Geographic Location.....	155
8	Loss Estimates .....	157
9	Vulnerability and Community Development Analysis for Landslide Hazard .....	158
10	Hazard Evaluation and Impact/Consequence Assessment .....	159
11	1.6.8 Non-Rotational Winds.....	160
12	Hazard Extent .....	160
13	History/Previous Occurrences.....	161
14	Future Probability.....	164
15	Geographic Location.....	165
16	Loss Estimates .....	165
17	Vulnerability & Community Development Analysis .....	168
18	Hazard Evaluation and Impact/Consequence Assessment .....	170
19	1.6.9 Tornado .....	171
20	Hazard Extent .....	171
21	Historic/Previous Occurrences .....	172
22	Future Probability.....	174
23	Geographic Location.....	175
24	Loss Estimates .....	175
25	Vulnerability and Community Development Analysis.....	176
26	Hazard Evaluation and Impact/Consequence Assessment .....	179
27	1.6.10 Wildfire .....	180
28	Hazard Extent .....	180
29	Historic/Previous Occurrences .....	180
30	Future Probability.....	181
31	Geographic Location.....	182
32	Loss Estimates .....	183
33	Vulnerability and Community Development Analysis.....	183
34	Hazard Evaluation and Impact/Consequence Assessment .....	188
35	1.6.11 Winter Storm.....	189



1	Hazard Extent .....	191
2	History/Previous Occurrences .....	192
3	Future Probability .....	194
4	Geographic Location .....	195
5	Loss Estimates .....	195
6	Vulnerability and Community Development Analysis .....	195
7	Hazard Evaluation and Impact/Consequence Assessment .....	198
8	1.6.12 Solar Storm .....	199
9	Hazard Extent .....	199
10	History/Previous Occurrences .....	199
11	Future Probability .....	200
12	Geographic Location .....	200
13	Loss Estimates .....	200
14	Vulnerability and Community Development Analysis .....	201
15	1.6.13 Risk Assessment Methodology .....	202
16	Hazard Assessment Methodology .....	202
17	Community Vulnerability Risk and Resiliency (CVR2) .....	203
18	Limitations .....	206
19	Hazard Risk Determination .....	206
20	Determining the Probability .....	206
21	Determining the Consequence .....	208
22	1.6.14 Hazard Rankings .....	210
23	Repetitive Loss Summary .....	214
24	Public Survey Comparison .....	215
25	1.7 Mitigation Strategies .....	218
26	1.7.1 Mitigation Goals and Objectives .....	218
27	1.7.2 Mitigation Strategies and Actions .....	219
28	Mitigation Action Plan .....	220
29	Mitigation Strategy/Action Timeline Parameters .....	222
30	2021 Hazard Mitigation Priorities .....	224
31	Ongoing, Completed, or Removed Actions .....	270
32	1.7.3 Plan Integration Strategy .....	274
33	1.7.4 NFIP Mitigation Actions .....	275
34	Section 1.8 Plan Maintenance and Implementation .....	277
35	1.8.1 Formal Review Process .....	278



1	1.8.2 Monitoring, Evaluating, and Updating the Plan .....	279
2	1.8.3 The Five-Year Action Plan .....	280
3	1.8.4 Annual Mitigation Steering Committee Meeting .....	282
4	Plan Evaluation .....	282
5	Review of Mitigation Actions .....	282
6	Meeting Documentation .....	282
7	1.8.5 Continued Public Involvement .....	283
8	1.8.6 Implementation and Integration through Existing Plans and Programs .....	284
9	Appendix A: Public Involvement & Steering Committee Meetings .....	285
10	A.1 Survey Questions .....	286
11	A.2 Survey Results .....	298
12	A.3 Press Releases .....	313
13	A.4 Sign-in Sheets .....	319
14		
15		
16		
17		

DRAFT



1 **Section 1.1 Executive Summary**

2 [A complete Executive Summary will be included in the final version of the Plan.]

DRAFT



## 1 Section 1.2 Introduction

### 2 Emergency Management Background

3 Over the past fifty years, the meaning and scope of emergency management has evolved in  
4 response to changes in political, military, and natural environments. Emergency management  
5 has grown from a narrow civil defense focus to its present position of providing a wide array of  
6 services in response to natural, technological, and human-caused hazards.

7 Emergency management began after World War II. The federal government created a  
8 nationwide shelter program under the Civil Defense Act, and the first federal assistance to state  
9 and local governments was provided under civil defense programs. Response and recovery  
10 from natural, technological, and human-caused disasters were to be managed within the  
11 jurisdictions of state and local governments.

12 In 1979, the Federal Emergency Management Agency (FEMA) was established to assist in  
13 responding to war-caused emergencies, nuclear incidents, and natural, technological, and  
14 human-caused disasters. In the 1980s, response and recovery efforts from other than war  
15 became eligible for federal funding. Emergency management also experienced a key policy  
16 shift. Focus shifted from one of nuclear war preparedness to a more balanced focus on natural,  
17 technological, and human-caused hazards and disasters. An “all-hazards” approach was  
18 emphasized. Federal assistance became available for preparedness, response, and recovery  
19 efforts. In the 1990s, increasing demand on federal funds for disaster recovery assistance  
20 prompted changes in federal policy to emphasize mitigation and provide technical assistance to  
21 build state and local government capabilities to deal more independently with emergencies and  
22 disasters.

23 This evolution resulted in a shift from federal initiatives to fostering local and state developed  
24 and delivered programs. Within this framework, local emergency management organizations  
25 work to implement local, state, and federal emergency management and homeland security  
26 policy. By working collaboratively with governmental agencies, private industry, and citizens,  
27 and by providing technical assistance and support, local emergency management organizations  
28 are expanding capabilities to provide a broad spectrum of professional services.

29 In the 1990s, federal, state, and local governments recognized the increasing threat of terrorism  
30 based on domestic and foreign incidents, including the bombing of the New York World Trade  
31 Center in 1993, the 1995 bombing of the Alfred P. Murrah Federal Building in Oklahoma, the  
32 bombing of the Khobar Towers in Saudi Arabia in 1996, and the bombing of the U.S.S. Cole in  
33 Yemen in 2000. These incidents demonstrated terrorists’ willingness to use weapons of mass  
34 destruction and resulted in the federal government examining the causes and effects of these  
35 incidents in order to shape U.S. policy and fund domestic anti-terrorism preparedness activities.

36 The September 11, 2001, terrorist attacks on the New York World Trade Center and the  
37 Pentagon was a defining moment in terrorism and resulted in the restructuring of domestic and  
38 foreign policy and the development of nationwide initiatives to detect and prevent terrorist  
39 attacks and protect critical infrastructure. The Department of Homeland Security was created  
40 and the view of emergency management was expanded to a comprehensive set of services  
41 encompassing seven phases - detection, prevention, preparedness, protection, mitigation,  
42 response, and recovery.



1 Since this implementation of Homeland Security and Emergency Management, several attempts  
2 of terrorist attacks on the homeland have occurred. Three attempts on airliners (the shoe  
3 bomber, the underwear bomber, and the 2010 cargo package attack) were thwarted. Other  
4 serious attempts to bomb or attack military bases, subways, and Times Square were also shut  
5 down without loss of life or property. The Fort Hood shooting was the only successful terrorist  
6 attack, resulting in 13 seriously wounded or killed military personnel.

## 7 Hazard Mitigation Background

8 Hazard mitigation is defined as any sustained action to reduce or eliminate long-term risk to  
9 human life and property from hazards. The Federal Emergency Management Agency (FEMA)  
10 has made reducing hazards one of its primary goals. Hazard mitigation planning and the  
11 subsequent implementation of the projects, measures, and policies developed as part of this  
12 Plan, is a primary mechanism in achieving FEMA's goal.

13 The federal Disaster Mitigation Act of 2000 requires jurisdictions to develop and maintain a  
14 Multi-Hazard Mitigation Plan (HMP) to remain eligible for certain federal disaster assistance and  
15 hazard mitigation funding programs. Renewal of the plan every five years is required to  
16 encourage the continual awareness of mitigation strategies. For the National Flood Insurance  
17 Program (NFIP) communities to be eligible for future mitigation funds, they must adopt the HMP.

18 The following disasters were declared in the LENOWISCO Planning District during the HMP  
19 Planning Period (2015-2020).

<b>FEMA Disaster Declarations</b> <i>Source: FEMA</i>			
<b>Year</b>	<b>Disaster Number</b>	<b>Event</b>	<b>Applicable Jurisdictions</b>
2018	3403	Hurricane Florence	Lee, Scott, and Wise Counties
2020	3448, 4512	COVID-19 Pandemic	Lee, Scott, and Wise Counties

20

## 21 Plan Description

22 Natural, technological, and human-caused hazards pose a threat to every citizen and  
23 community within the LENOWISCO Planning District on some level and frequency. The process  
24 of hazard mitigation planning is a critical part of any community's planning program. Because  
25 most hazards occur infrequently, mitigation programs for hazards are usually initiated as a  
26 reaction to recovery from the most recent disaster. This form of hazard mitigation response is  
27 more costly, both in property and human loss, than is pre-disaster planning and mitigation.

28 Local Mitigation Plans must be updated and resubmitted to FEMA for approval every five (5)  
29 years in order to continue eligibility for FEMA hazard mitigation assistance programs. The  
30 mitigation planning regulation at 44 CFR §201.6(d)(3) states:

31 "A local jurisdiction must review and revise its plan to reflect changes in development, progress  
32 in local mitigation efforts, and changes in priorities, and resubmit it for approval within five (5)  
33 years in order to continue to be eligible for mitigation project grant funding. Plan updates must  
34 demonstrate that progress has been made in the past 5 years for Local Mitigation Plans to fulfill  
35 commitments outlined in the previously approved plan. This involves a comprehensive review  
36 and update of each section of the Local Mitigation Plan and a discussion of the results of



1 evaluation and monitoring activities detailed in the Plan Maintenance section of the previously  
2 approved plan. Plan updates may validate the information in the previously approved plan, or  
3 may involve a major plan rewrite.”

4 The process of all-hazard mitigation planning is the first step toward protecting a community  
5 from losses associated with hazards and resulting disasters. With regard to hazard mitigation,  
6 the Federal Emergency Management Agency (FEMA) provides the following definitions:

- 7 • **Hazard mitigation:** Any sustained action taken to reduce or eliminate the long-term risk  
8 to human life and property from hazards.
- 9 • **Planning:** The act or process of making or carrying out plans, specifically, the  
10 establishment of goals, policies, and procedures for a social or economic unit.

### 11 Plan Purpose

12 This Plan was developed to demonstrate a commitment to reducing or eliminating the impact of  
13 natural, technological, and human-caused hazards, and to support efficient and effective  
14 response and recovery. The Plan addresses myriad risks and degrees of vulnerability,  
15 mitigation goals, objectives, and strategies.

16 The LENOWISCO Planning District Hazard Mitigation Plan was developed in order to ensure  
17 the Planning District's future eligibility for federal disaster mitigation funds through the Hazard  
18 Mitigation Grant Program as provided through the Robert T. Stafford Disaster Relief and  
19 Emergency Assistance Act, amended by the Disaster Mitigation Act of 2000. The Plan also  
20 ensures access to other federal programs, i.e., Pre-Disaster Mitigation (PDM) and Flood  
21 Mitigation Assistance (FMA). Although the LENOWISCO Planning District and local  
22 communities would remain eligible for certain emergency assistance and Human Services  
23 programs, the District understands that without an approved hazard mitigation plan, it and all  
24 participating jurisdictions would be ineligible for other disaster recovery programs such as Fire  
25 Management and Public Assistance.

26 This Plan is structured through the planning requirements detailed in 44 Code of Federal  
27 Regulation (CFR) Part 201. The key purposes of this 2013 Plan are:

- 28 • To involve members of the counties, cities, towns, other agencies, and the public to draft  
29 and adopt a mitigation action plan that serves as the blueprint for future development  
30 and preparedness activities across the LENOWISCO Planning District;
- 31 • To prioritize loss reduction and emergency preparedness activities for disasters;
- 32 • To determine areas within the LENOWISCO Planning District that may be vulnerable to  
33 various hazards;
- 34 • To develop strategies and best practices to avoid and mitigate the impact of hazards.

35





## 1 **Section 1.3 Prerequisites**

2 The 2021 LENOWISCO Hazard Mitigation Plan meets the requirements of the Disaster  
3 Mitigation Act of 2000, which amended the Robert T. Stafford Disaster Relief and Emergency  
4 Assistance Act to require state, local, and tribal entities to closely coordinate mitigation planning  
5 and implementation efforts.

6

DRAFT



1 **1.3.1 Plan Adoption**

2 This Plan represents a comprehensive description of LENOWISCO's commitment to  
 3 significantly reduce or eliminate the potential impacts of disasters through planning and  
 4 mitigation. Adoption by the local governing bodies within the District legitimizes the Plan and  
 5 authorizes responsible agencies to implement mitigation responsibilities and activities.

6 To be eligible for federal mitigation funding, each participating jurisdiction must adopt the plan.

7 After a thorough review, the participating jurisdictions adopted the plan on the dates highlighted  
 8 in the table below. The table also notes the jurisdictions that did not participate in the plan.

9 Under the Planning Process section (1.4), documentation of communication with the non-  
 10 participating jurisdictions is noted.

**TABLE: Plan Adoption by Jurisdictions**

Participating Jurisdiction	Adopting Body (Signatory)	Date of Adoption
Lee County		
Scott County		
Wise County		
City of Norton		
Town of Jonesville	Did not participate in plan update	
Town of Pennington Gap		
Town of St. Charles		
Town of Clinchport	Did not participate in plan update	
Town of Duffield	Did not participate in plan update	
Town of Dungannon	Did not participate in plan update	
Town of Gate City		
Town of Nickelsville	Did not participate in plan update	
Town of Weber City	Did not participate in plan update	
Town of Appalachia	Did not participate in plan update	
Town of Big Stone Gap		
Town of Coeburn		
Town of Pound		
Town of St. Paul		
Town of Wise		

11

12



- 1 [Insert Adoption Letter Upon FEMA Approval Pending Adoption]
- 2 Following Federal review and approval, the participating jurisdictions in this plan intend to
- 3 formally adopt the plan by Resolution or Ordinance.
- 4 [Insert FEMA Approval Letter Upon Receipt]
- 5

DRAFT



### 1 1.3.2 Planning Teams & Jurisdiction Participation

2 Nineteen jurisdictions were invited to participate in the planning process. Representatives not  
 3 only attended the meetings, but also participated by gathering appropriate data and historical  
 4 information, completed the community preparedness survey, participated in their community  
 5 hazard analysis, identified new mitigation strategies, updated past mitigation strategies, and  
 6 participated in other efforts (i.e. webinars, phone interviews, and reviewing drafts). Local  
 7 mitigation planning team representatives and their contact information and the documentation of  
 8 participation in the Plan update are available below and sign-in sheets from meetings are in  
 9 the Public Meetings section (1.4.2).

**TABLE: Planning Team Participants**

Name	Organization	Title	Role in HMP	2013 Plan Participant	2021 Plan Participant
Frank Kibler	LENOWISCO Planning District	Senior Planner	Manager	X	X
Todd Lagow	City of Norton	Fire Chief/Emergency Operations Coordinator	Jurisdiction Stakeholder		X
Stephen McElroy	City of Norton	Director of Public Works	Jurisdiction Stakeholder		X
Dane Poe	Lee County	County Administrator	Jurisdiction Stakeholder	X	X
Jeff Brickey	Scott County	Emergency Operations Coordinator	Jurisdiction Stakeholder		X
Jessica Swinney	Wise County	Emergency Operations Coordinator	Jurisdiction Stakeholder	X	X
Matthew Bright	Town of Big Stone Gap	Building & Zoning Official	Jurisdiction Stakeholder		X
Stephen Lawson	Town of Big Stone Gap	Town Manager	Jurisdiction Stakeholder		X
Jimmy Williams	Town of Coeburn	Town Manager	Jurisdiction Stakeholder		X
Greg Jones	Town of Gate City	Town Manager	Jurisdiction Stakeholder		X
Brian Skidmore	Town of Pennington Gap	Fire Chief	Jurisdiction Stakeholder		X
Jane Bennett	Town of Pound	Interim Town Manager	Jurisdiction Stakeholder		X
Earl Carter	Town of St. Paul	Public Works Director	Jurisdiction Stakeholder		X
Laura Roberts	Town of Wise	Town Planner	Jurisdiction Stakeholder	X	X



1 Participating Jurisdictions

2 The participating jurisdictions seeking approval under this plan are:

- 3 • Lee County
- 4 • Scott County
- 5 • Wise County
- 6 • City of Norton
- 7 • Town of Big Stone Gap
- 8 • Town of Coeburn
- 9 • Town of Gate City
- 10 • Town of Pennington Gap
- 11 • Town of Pound
- 12 • Town of St. Paul
- 13 • Town of Wise

14 Contact information for representatives of each participating jurisdiction is listed above in the  
15 Core Planning Team. All team members were initially invited by e-mail with a follow-up phone  
16 call. **[Update table below after review process.]**

<b>TABLE: Neighboring County Reviewers</b>			
<b>County</b>	<b>2021 Representative</b>	<b>Email</b>	<b>2021 Description of Participation</b>

17

18



### 1 1.3.3 Plan Authority

2 This 2021 Plan update was developed in accordance with federal, state, and local rules and  
 3 regulations governing local hazard mitigation plans. The Plan authority will be routinely  
 4 monitored and revised to maintain compliance with the below provisions, rules, and legislation:

TABLE: Plan Authority		
Authority	Authority Description	Date
Federal	The National Flood Insurance Program (NFIP) was established with the passage of the National Flood Insurance Act	1968
Federal	Flood Mitigation Assistance Program (FMA) was created as part of the National Flood Insurance Reform Act (NFIRA)	1994
Federal	Section 322, Mitigation Planning, of the Robert T. Stafford Disaster Relief and Emergency Assistance Act, as enacted by Section 104 of the Disaster Mitigation Act of 2000 (P.L. 106-390)	10/30/2000
Federal	Pre-Disaster Mitigation (PDM) Program was authorized by section 203 of the 2000 Stafford Act, 42 USC (Public Law 106-390)	10/30/2000
Federal	FEMA's Interim Final Rule published in the Federal Register on February 26, 2002, at 44 CFR Part 201 and 206	02/26/2002
State	§ 44-146.18. Department of Emergency Management; administration and operational control; coordinator and other personnel; powers and duties. Section B3 Notates that The Department shall promulgate plans and programs that are conducive to adequate disaster mitigation preparedness, response, and recovery programs.	--

### 6 Hazard Mitigation Legislation

#### 7 *Disaster Mitigation Act of 2000*

8 To support the expanded role of emergency management, the Disaster Mitigation Act of 2000,  
 9 (DMA2K), commonly known as the Stafford Act. Section 322, was passed. An amendment to  
 10 the Act, dealing with the development of local hazard mitigation plans. DMA2K was signed into  
 11 law on October 30, 2000 (Public Law 106-390) and amended the Stafford Act to establish a  
 12 national program for pre-disaster mitigation, streamline the administration of disaster relief, and  
 13 control federal disaster assistance costs. The Interim Final Rule for planning provisions (44 CFR  
 14 Part 201) is published in the Federal Register. Local hazard mitigation planning requirements  
 15 are described in 44 CFR Part 201.6. Congress envisioned that implementation of these new  
 16 requirements would result in the following benefits:

- 17 • Reduction of loss of life and property, human suffering, economic disruption, and  
 18 disaster costs.
- 19 • Prioritization of hazard mitigation planning at the local level, with an increased emphasis  
 20 on planning and public involvement, assessing risks, implementing loss reduction  
 21 measures, and ensuring critical services/facilities survive a disaster.
- 22 • Establishment of economic incentives, awareness, and education to state, tribal, and  
 23 local governments that would result in forming community-based partnerships,



1 implementing effective hazard mitigation measures, leveraging additional non-federal  
2 resources, and establishing commitments to long-term hazard mitigation efforts.

### 3 *Regulation 44 CFR Part 201*

4 44 CFR Part 201 regulations reflect the need for state, tribal, and local governments to closely  
5 coordinate mitigation planning and implementation efforts. State, tribal, and local governments  
6 must have a state- and FEMA-approved Local Mitigation Plan in order to receive FEMA hazard  
7 mitigation assistance and to apply for and/or receive the following project grants:

- 8 • Hazard Mitigation Grant Program (HMGP)
- 9 • Pre-Disaster Mitigation (PDM)
- 10 • Flood Mitigation Assistance (FMA)
- 11 • Repetitive Flood Claims (RFC)
- 12 • Severe Repetitive Loss (SRL)
- 13 • Community Rating System (CRS)

14 Each hazard mitigation plan must, at minimum, address or include the following items:

- 15 • Plan adoption by all participating jurisdictions
- 16 • A description of the planning process including public involvement
- 17 • Hazard identification and risk assessment
- 18 • Mitigation strategy
- 19 • Plan implementation and maintenance procedures
- 20 • Any specific state requirements

21 The mitigation plan requirements in 44 CFR Part 201 emphasize greater interaction between  
22 state and local mitigation activities, and highlights the need for improved linkage between state  
23 and local mitigation plans. Under 44 CFR §201.4(c)(4), states are required to coordinate  
24 mitigation planning with tribal and local jurisdictions and document the funding and technical  
25 assistance they will provide. States should refer to local mitigation plans to improve the level of  
26 detail and comprehensiveness of statewide risk assessments and coordinate mitigation goals  
27 and objectives with local goals and objectives. Similarly, local governments may refer to the  
28 state mitigation plan where information may be useful for local mitigation strategy development.

### 29 Hazard Mitigation Grant Program

30 In 1988, Congress established the Hazard Mitigation Grant Program (HMGP) in Section 404 of  
31 the Stafford Act. In 2002, regulations pertaining to the HMGP were changed by 44 CFR Part  
32 206. An Interim Final Rule was issued wherein the final compliance date was set to November  
33 1, 2004 for all governments to have a FEMA-approved mitigation plan. The HMGP assists  
34 states and local communities to implement long-term hazard mitigation measures by providing  
35 federal funding after a major disaster declaration. Eligible applicants include state and local  
36 agencies, tribal organizations, and certain non-profit organizations. Examples of HMGP projects  
37 include:

- 38 • Property acquisition and relocation projects
- 39 • Structural retrofitting to minimize damages from high winds, earthquake, flood, wildfire,  
40 or other hazards
- 41 • Elevation of flood-prone structures



- 1       • Vegetative management programs

2       Pre-Disaster Mitigation Program

3       The Pre-Disaster Mitigation (PDM) Program is authorized by section 203 of the 2000 Stafford  
4       Act. Funding for the program is provided to assist state, tribal, and local governments in  
5       implementing cost-effective hazard mitigation activities. Two types of grants are offered under  
6       the PDM Program.

- 7       • Planning Grants - Allocated funds to be used for hazard mitigation plan development.  
8       • Competitive Grants - Distributed funds using a competitive application process.

9       The minimum eligibility requirements for jurisdictions receiving PDM funds include:

- 10       • Participation in the National Flood Insurance Program (NFIP)  
11       • Must not be suspended or on probation from the  
12       • Must have a FEMA-approved hazard mitigation plan

13

DRAFT





## 1 Section 1.4 Planning Process

2 All areas within the LENOWISCO Planning District are vulnerable to natural, technological, and  
3 human-caused hazards that have the possibility of causing severe threats to the health, welfare,  
4 and security of its residents. The cost of the response to and recovery from the potential  
5 disasters, regarding the potential loss of life or property, can be lessened when attention is  
6 turned to mitigating their impacts and effects before they occur or reoccur.

7 This Multi-Jurisdiction All-Hazard Mitigation Plan (HMP) seeks to identify LENOWISCO's  
8 hazards and understand their impact on vulnerable populations and infrastructure. With  
9 that understanding, the Plan sets forth solutions that if implemented, have the potential to  
10 significantly reduce the threat to life and property. The HMP is based on the premise that hazard  
11 mitigation works. With increased attention to managing natural hazards and land use,  
12 communities can reduce the threats to citizens and infrastructure. Many mitigation strategies  
13 can be implemented at minimal cost and social impact.

14 This is not an emergency response plan; however, the HMP can be used to identify gaps and  
15 enhance coordination of other plans, including comprehensive emergency management plans,  
16 continuity of operations, and emergency response plans. The primary focus of the HMP is to  
17 support better decision making directed toward lessening hazard impact and the implementation  
18 of activities or projects that will eliminate or reduce the risk for those that may already have  
19 exposure to a natural hazard threat.

### 20 Purpose

21 The purposes of the HMP are:

- 22 • Fulfill federal and local mitigation planning responsibilities;
- 23 • Promote pre- and post-disaster mitigation measures with short/long-range strategies to  
24 minimize suffering, loss of life, impact on traditional culture, and damage to property and  
25 the environment;
- 26 • Eliminate or minimize conditions that would have an undesirable impact on the people,  
27 culture, economy, environment, and well-being of the Planning District at large.
- 28 • Enhance elected officials', departments', and the public's awareness of the threats to the  
29 community's way of life, and of what can be done to prevent or reduce the vulnerability  
30 and risk.

### 31 Scope

32 This Multi-Jurisdiction All-Hazard Mitigation Plan covers all of the areas within the eleven  
33 participating jurisdictions.

### 34 Mission Statement

35 The LENOWISCO Planning District Hazard Mitigation Plan (HMP) sets forth public policy  
36 designed to protect citizens, critical facilities, infrastructure, private and public property, the local  
37 economy, and the environment from risks associated with natural and human-caused hazards.

38



## 1 Federal and State Plan Compliance and Integration

2 This HMP is designed to comply with the requirements of the Robert T. Stafford Disaster Relief  
3 and Emergency Assistance Act, as amended, and Related Authorities and 44 CFR Part 201,  
4 which states that local governments, to be eligible for pre-disaster and/or post-disaster  
5 mitigation funds, must have an approved Hazard Mitigation Plan in place. The Plan is also  
6 designed to comply with the Federal Emergency Management Agency (FEMA) and Virginia  
7 Department of Emergency Management (VDEM), guidance documents (particularly the Local  
8 Multi-Hazard Mitigation Planning Guidebook dated 2018), and other applicable federal, state,  
9 and local regulations.

## 10 Plan Use

11 The Plan should be used to help officials within LENOWISCO plan, design, and implement  
12 programs and projects that will help reduce the jurisdiction's vulnerability to natural,  
13 technological, and human-caused hazards. The Plan should also be used to facilitate inter-  
14 jurisdiction coordination and collaboration related to all-hazard mitigation planning and  
15 implementation within the planning district. Lastly, the Plan should be used to develop or  
16 provide guidance for local emergency response planning. If adopted, this Plan will achieve  
17 compliance with the Disaster Mitigation Act of 2000.

## 18 Hazard Mitigation

19 Hazard mitigation is defined as any cost-effective action(s) that has the effect of reducing,  
20 limiting, or preventing vulnerability of people, culture, property, and the environment to  
21 potentially damaging, harmful, or costly hazards. Hazard mitigation measures which can be  
22 used to eliminate or minimize the risk to life, culture, and property, fall into three categories:

- 23 1. Keep the hazard away from people, property, and structures.
- 24 2. Keep people, property, or structures away from the hazard.
- 25 3. Reduce the impact of the hazard on victims, i.e., insurance.

26 Hazard mitigation measures must be practical, cost-effective, and culturally, environmentally,  
27 and politically acceptable. Actions taken to limit the vulnerability of society to hazards must not  
28 in themselves be more costly than the anticipated damages.

29 The primary focus of hazard mitigation planning must be at the point at which capital investment  
30 and land use decisions are made, based on vulnerability. Capital investments, whether for  
31 homes, roads, public utilities, pipelines, power plants, or public works, determine to a large  
32 extent the nature and degree of hazard vulnerability of a community. Once a capital facility is in  
33 place, very few opportunities will present themselves over the useful life of the facility to correct  
34 any errors in location or construction with respect to the hazard vulnerability. It is for this reason  
35 that zoning and other ordinances, which manage development in high vulnerability areas, and  
36 building codes, which ensure that new buildings are built to withstand the damaging forces of  
37 the hazards, are often the most useful tool in mitigation that a jurisdiction can implement.

38 Since the priority to implement mitigation activities is usually very low in comparison to the  
39 perceived threat, some important mitigation measures take time to implement. Mitigation  
40 success can be achieved, however, if accurate information is portrayed through complete  
41 hazard identification and impact studies, followed by effective mitigation management.



### 1.4.1 Existing Plans and Technical and Fiscal Resource Review

The LENOWISCO Planning District completed its first HMP in 2005. An update was conducted in 2013. The current update was completed in 2021. The table below lists the plans, studies, and reports reviewed prior to the update of this Plan. The Capability Assessment includes additional information utilized in this plan.

**TABLE: Documents Reviewed for this Plan Update**

Year	Title	Author(s)	Link/Location of Plan	Integration into HMP
2020	LENOWISCO PDC Community Profile	Virginia Employment Commission	<a href="http://www.virginiaworks.com/Portals/200/Local%20Area%20Profiles/5109000301.pdf">www.virginiaworks.com/Portals/200/Local%20Area%20Profiles/5109000301.pdf</a>	Used to develop the District Community Profile and District Vulnerability Analysis
2020	Wise County Comprehensive Plan	Wise County Planning Commission	<a href="http://www.wisecounty.org/planupdate/2020_comp_plan.pdf">www.wisecounty.org/planupdate/2020_comp_plan.pdf</a>	Used to develop the County Community Profile, Hazard Vulnerability Analysis, and design applicable mitigation actions
2020	Lee County Comprehensive Plan	Lee County Planning Commission	<a href="http://www.leecova.org/pdf/lee%20County%20Comprehensive%20Plan-Adopted%202020.pdf">http://www.leecova.org/pdf/lee%20County%20Comprehensive%20Plan-Adopted%202020.pdf</a>	Used to develop the County Community Profile, Hazard Vulnerability Analysis, and design applicable mitigation actions
2019	Comprehensive Economic Development Strategy	LENOWISCO Planning District Commission	<a href="http://www.lenowisco.org/reports-and-media.html">www.lenowisco.org/reports-and-media.html</a>	Used to develop the economic profile, support mitigation cost-benefit analysis, and analyzed current and future land use.
2018	Commonwealth of Virginia Hazard Mitigation Plan	Virginia Department of Emergency Management	<a href="http://www.vaemergency.gov/agency/planning/">www.vaemergency.gov/agency/planning/</a>	Used to ensure compliance with State requirements, enhance hazard profiles, and develop relevant mitigation actions
2018	American Community Survey	U.S. Census Bureau	<a href="http://www.census.gov/programs-surveys/acs">www.census.gov/programs-surveys/acs</a>	Used to develop the demographic profiles and statistically support vulnerability analysis
2017	LENOWISCO Agricultural Strategic Plan	LENOWISCO Planning District Commission	<a href="http://www.lenowisco.org/reports-and-media.html">www.lenowisco.org/reports-and-media.html</a>	Used to analyze hazard impact to crops and the economy
2017	Scott County Comprehensive Plan	Scott County Planning Commission	<a href="http://www.scottcountywa.com/2017-CompPlanFinal.pdf">www.scottcountywa.com/2017-CompPlanFinal.pdf</a>	Used to develop the County Community Profile, Hazard Vulnerability Analysis, and design applicable mitigation actions
2013	Local Mitigation Planning Handbook	Federal Emergency Management Agency	<a href="http://www.fema.gov/emergency-managers/risk-management/hazard-mitigation-planning/create-hazard-plan">www.fema.gov/emergency-managers/risk-management/hazard-mitigation-planning/create-hazard-plan</a>	Used to develop and crosswalk the mitigation plan structure and components.
2003	City of Norton 2020 Comprehensive Plan	City of Norton Planning Commission	<a href="http://www.nortonva.org/DocumentCenter/View/738/Comprehensive-Plan?bidId=8">www.nortonva.org/DocumentCenter/View/738/Comprehensive-Plan?bidId=8</a>	Used to develop the City Community Profile, Hazard Vulnerability Analysis, and design applicable mitigation actions



1 The LENOWISCO Planning District Board of Directors discusses and votes on several issues  
2 related to hazard mitigation, including:

- 3 • Water/ wastewater funding requests
- 4 • Allocation of construction funds
- 5 • Community Development Block Grant (CDBG) applications
- 6 • Updates on current improvement projects

7 Since a Hazard Mitigation Plan is only a part of the emergency planning, mitigation,  
8 preparedness, response, and recovery process, a second objective of the planning process was  
9 to coordinate Plan preparation with existing LENOWISCO Planning District emergency plans,  
10 programs, procedures, and organizations. For purposes of this Plan, existing hazard mitigation  
11 goals and objectives within the LENOWISCO Planning District were reviewed. It should be  
12 noted that this Plan does not replace any existing plans or programs but is intended to provide a  
13 reference on hazard mitigation to be used in planning and program development.

DRAFT



## 1 **1.4.2 Plan Participation**

2 The following section details the planning process, planning team meetings and participation,  
3 non-participating jurisdictions, public outreach including a community preparedness survey and  
4 public form, and the public plan review and feedback process.

### 5 Planning Process Detailed

6 In summary, the planning process consisted of the following steps:

#### 7 *Organize Resources*

8 The LENOWISCO Planning District created a planning committee for the HMP update,  
9 representing the Planning District and participating jurisdictions. Members of the planning  
10 committee completed hazard profile worksheets and mitigation action worksheets, participated  
11 in individual mitigation action brainstorm meetings, facilitated public involvement, and reviewed  
12 the HMP draft to provide feedback for improvement. Four virtual planning meetings occurred  
13 during the process, which are detailed in the Planning Team Meetings section (1.4.2.2).

#### 14 *Identify Hazards*

15 The planning committee identified hazards for the LENOWISCO Planning District based on their  
16 frequency and other relevant resources, including:

- 17 • Hazard planning documents developed by state, federal and private agencies
- 18 • NOAA (National Oceanic and Atmospheric Administration) National Centers for  
19 Environmental Information (formerly National Climatic Data Center-NCDC) data dating  
20 back to 1950
- 21 • Data from the United States Geological Survey (USGS), Virginia Department of  
22 Conservation and Recreation, and Virginia Department of Mines, Minerals, and Energy
- 23 • Data from the 2018 Commonwealth of Virginia Hazard Mitigation Plan
- 24 • Other sources highlighted in Section 1.4.1 Existing Plans and Technical Resources

#### 25 *Identify Vulnerabilities*

26 The planning committee examined the potential effects to the LENOWISCO Planning District of  
27 the listed hazards by identifying vulnerable populations, infrastructure, critical services, facilities,  
28 and the environment in the first meeting. Team members geographically identified vulnerabilities  
29 using HAZUS-MH and Geographical Information System (GIS).

#### 30 *Develop Mitigation Goals*

31 As required by FEMA, the planning effort was centered on community-supported hazard  
32 reduction goals to be implemented and evaluated based on measurable objectives. Mitigation  
33 projects are to be assessed against the established mitigation goals to ensure that the selected  
34 projects reduce risk as desired.

35



1 ***Risk Assessment***

2 For each identified hazard, the planning committee created a profile addressing the hazard's  
3 probability, severity, extent, and potential impacts associated with each hazard. The team then  
4 used local resources to inventory the jurisdiction assets and estimate losses. The committee  
5 provided input and subject-matter expertise throughout this process. A standardized risk ranking  
6 methodology was developed, enabling stakeholders to compare risk from one jurisdiction to the  
7 other. The methodology created that measured and weighed the following variables: probability,  
8 population exposure, property exposure, property damages, economic impact, and catastrophic  
9 potential. A quantitative assessment was first conducted, followed by input from key  
10 stakeholders from that community. Minor adjustments were made if needed. The assessment  
11 provides a holistic risk ranking of the LENOWISCO Planning District, whereas the individual  
12 jurisdiction assessments provide a very specific and unique view of risk as it pertains to that  
13 community.

14 ***Develop Mitigation Strategies***

15 The planning team met with representatives of each participating jurisdiction to develop and  
16 prioritize mitigation strategies and action items that would reduce the costs of disaster response  
17 and recovery, protect people and infrastructure, and minimize overall disruption to each  
18 jurisdiction in the event of a disaster.

19 ***Write Plan***

20 The HMP meets the requirements set forth by FEMA in the FEMA PDM Criteria Crosswalk. Plan  
21 drafts were presented in electronic form to committee members and the public. The HMP was  
22 also shared with neighboring jurisdictions for review.

23 ***Public Involvement***

24 A comprehensive public survey was distributed through several channels including social  
25 media, newspaper, and web outlets. A total of 166 residents completed the survey. In addition,  
26 one virtual public meeting occurred during the draft review phase. The draft of the plan was  
27 made public for review and details for the public announcements are included under the Public  
28 Forums and Outreach section (1.4.2.4).

29 ***Plan Review***

30 The planning committee reviewed both the draft HMP as well as their respective jurisdiction  
31 annexes during the drafting phase. The planning committee assessed the HMP using the most  
32 current FEMA HMP Review Crosswalks. Once the HMP was completed, it was submitted, as a  
33 draft to the committee and the public to review. Following the public comment time period and  
34 after changes were made, the plan was submitted to the Virginia Department of Emergency  
35 Management Hazard Mitigation Officer, and then to FEMA Region III Hazard Mitigation Officer  
36 for review. The LENOWISCO Planning District Commission reviewed the HMP in a parallel time  
37 frame.

38





1 **Plan Adoption**

2 The LENOWISCO Planning District coordinated the effort to ensure the HMP was formally  
3 adopted by each participating jurisdiction (see Plan Adoption section 1.3.1). A letter of  
4 Promulgation is provided in the Plan. Additionally, each participating jurisdiction will be  
5 requested to adopt the Plan by resolution with the respective mayors signing the appropriate  
6 multi-jurisdiction participation document.

7 **Planning Team Meetings**

8 The planning committee conducted four virtual meetings through GoToMeeting, as this HMP  
9 was completed during the COVID-19 Pandemic, restricting any in-person engagement. The four  
10 meetings are summarized below, in alignment with the stage of the planning process detailed in  
11 the previous section.

12 **Meeting One: Identify Hazards**

13 The first planning committee virtual meeting took place on October 8, 2020. The objectives of  
14 this meeting were to outline the planning process, establish the project timeline, and outline data  
15 collection and plan review methods. The committee discussed the natural hazards to be  
16 included in the plan, and each jurisdiction was asked to complete a hazard worksheet outlining  
17 specific vulnerabilities and concerns for their community for each hazard.

18 Using an online polling tool, the planning committee members noted which hazards were of  
19 greatest concern to their communities. As shown in the figure below, Flooding and Winter Storm  
20 Events have posed the greatest risk across the LENOWISCO Planning District. Other questions  
21 posed to the planning committee included whether additional hazards should be added to the  
22 HMP, and where they saw the greatest opportunity for mitigation.

23 **FIGURE: Polling Results from Planning Team Meeting**

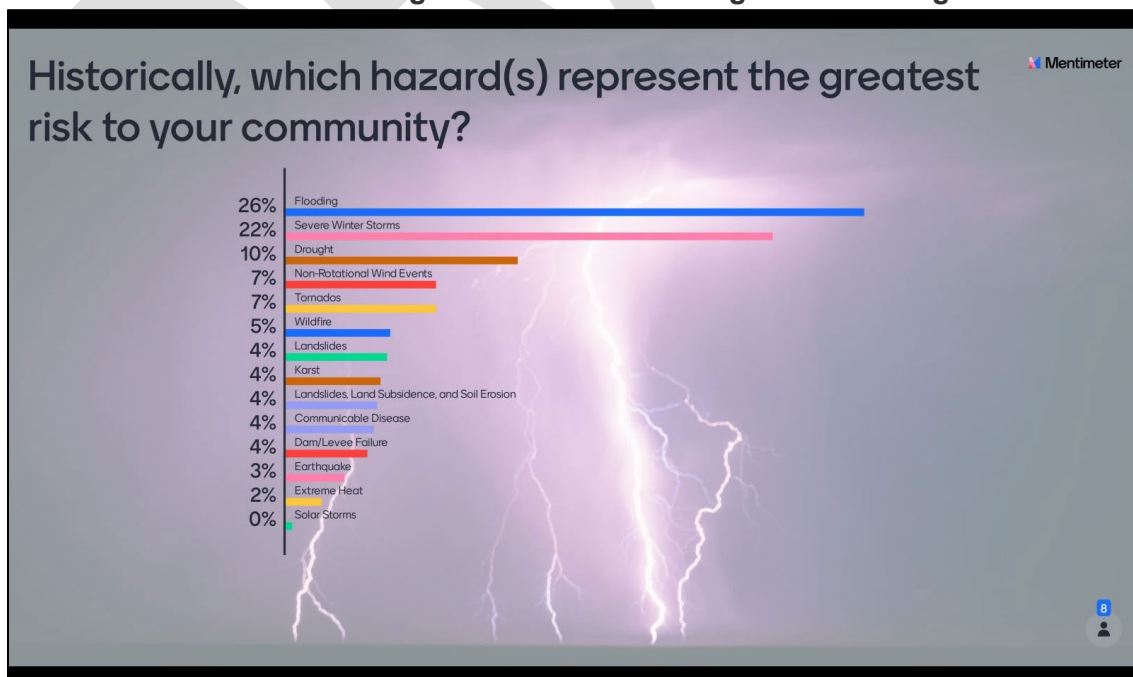



1

**FIGURE: Polling Results from Planning Team Meeting**



2

3 Eight of the eleven participating jurisdictions attended the first meeting. The LENOWISCO  
 4 Planning District followed-up directly with all jurisdictions after the meeting to encourage and  
 5 facilitate engagement. A complete list of participants is available in the table below.

**TABLE: Attendance for Stakeholder Meeting  
 October 8, 2020**

<b>Name</b>	<b>Organization</b>
Todd Lagow	City of Norton
Stephen McElroy	City of Norton
Fred Ramey	City of Norton
Alan Bailey	Lee County
Dane Poe	Lee County
Frank Kibler	LENOWISCO Planning District
Freda Starnes	Scott County
Greg Jones	Town of Gate City
Jane Bennet	Town of Pound
Earl Carter	Town of St. Paul
Laura Craft	Town of Wise
Karen Mullins	Wise County
Jessica Swinney	Wise County
Sara Harrington	VDEM All-Hazards Planning Team, Plan Approver
Betsy Lopez	Integrated Solutions Consulting – Project Lead
Leah Rausch	Integrated Solutions Consulting – Planner
Matt Stanley	Integrated Solutions Consulting – Principal Manager
Cassandra Wolff	Integrated Solutions Consulting – GIS Analyst / Planner
Ed Wolff	Integrated Solutions Consulting – Project Manager

6





1 **Meeting Two: Develop Mitigation Goals**

2 The second planning committee meeting focused on developing mitigation goals and actions for  
 3 each participating jurisdiction. The team provided feedback on the draft goal statements for the  
 4 2021 HMP, and how they guide the development of actions. The planning team reviewed the  
 5 benefits of mitigation, shared examples, outlined what information will need to be included for  
 6 each mitigation action, and how the actions may leverage future funding opportunities. The  
 7 committee shared any initial mitigation action ideas, including the need for generators for  
 8 emergency shelters, acquisition and demolition projects, and more.

9 Participating jurisdictions were asked to consult with local stakeholders and subject matter  
 10 experts to begin drafting mitigation action ideas using a provided worksheet (see figures on the  
 11 following pages), which would then be refined through one-on-one calls.

12 Ten of the eleven participating jurisdictions attended the second meeting. The LENOWISCO  
 13 Planning District followed-up directly with all jurisdictions after the meeting to encourage and  
 14 facilitate engagement. A complete list of participants is available in the table below.

**TABLE: Attendance for Stakeholder Meeting #2  
 December 16, 2020**

<b>Name</b>	<b>Organization</b>
Todd Lagow	City of Norton
Stephen McElroy	City of Norton
Dane Poe	Lee County
Frank Kibler	LENOWISCO Planning District
Jeff Brickey	Scott County
Matthew Bright	Town of Big Stone Gap
Stephen Lawson	Town of Big Stone Gap
Greg Jones	Town of Gate City
Brian Skidmore	Town of Pennington Gap
Jane Bennet	Town of Pound
Earl Carter	Town of St. Paul
Laura Roberts	Town of Wise
Jessica Swinney	Wise County
Betsy Lopez	Integrated Solutions Consulting – Project Lead
Leah Rausch	Integrated Solutions Consulting – Planner
Matt Stanley	Integrated Solutions Consulting – Principal Manager
Cassandra Wolff	Integrated Solutions Consulting – GIS Analyst / Planner
Ed Wolff	Integrated Solutions Consulting – Project Manager

15

16



1

**FIGURE: New Mitigation Action Worksheet (Page 1)**

Handout: New Mitigation Actions (LENOWISCO)

*Submitter's information:*

<b>Name</b>	
<b>Jurisdiction</b>	
<b>Organization/Department</b>	
<b>E-mail</b>	
<b>Phone Number</b>	

*Please describe the new mitigation action:*

<b>Mitigation Action Title</b> <i>Please utilize action verbs and exact locations when possible</i>	
<b>Description</b> (including purpose, benefit, and loss avoided)	

*New Action Details (scoring parameters noted at the end of the document):*

<b>Year Initiated</b>	<b>2021 (New Mitigation Action)</b>
<b>Applicable Jurisdiction</b>	
<b>Lead Agency/Organization</b>	
<b>Supporting Agencies/Organizations</b>	
<b>Potential Funding Source</b>	
<b>Cost</b>	
<b>Estimated Cost (High, Medium, Low)</b>	
<b>Benefits (High, Medium, Low)</b>	
<b>Priority (High, Medium, Low)</b>	
<b>Project Length (Short-term, Long-term, or Ongoing)</b>	
<b>Projected Completion Year or Ongoing</b>	

*Please indicate which goals apply to the new mitigation action. Select all that apply.*

<input checked="" type="checkbox"/>	Place an "X" by the applicable goals
<input type="checkbox"/>	<b>Goal 1: Protect the lives, health, and safety of LENOWISCO residents and visitors, maintain critical societal functions before, during, and after a disaster.</b>
<input type="checkbox"/>	<b>Goal 2: Identify and implement mitigation projects that will minimize a hazard's impact on existing and future developments, including reducing risk to NFIP repetitive loss and severe repetitive loss properties.</b>
<input type="checkbox"/>	<b>Goal 3: Incorporate mitigation into existing and future policies, plans, regulations, and laws in LENOWISCO.</b>
<input type="checkbox"/>	<b>Goal 4: Promote and support a whole community approach to mitigation that encourages residents, businesses, and public entities to become more disaster resilient.</b>

Page 1 of 5

2



1

**FIGURE: New Mitigation Action Worksheet (Page 2)**

Handout: New Mitigation Actions (LENOWISCO)

*STAPLEE Assessment: Please circle or highlight the best option and total the 7 rows.*

	Strongly Disagree (1)	Disagree (2)	Neither Agree or Disagree (3)	Agree (4)	Strongly Agree (5)
<b>Social:</b> Mitigation actions are acceptable to the community if they do not adversely affect a particular segment of the population, do not cause relocation of lower income people, and if they are compatible with the community's social and cultural values.	1	2	3	4	5
<b>Technical:</b> Mitigation actions are technically most effective if they provide a long-term reduction of losses and have minimal secondary adverse impacts.	1	2	3	4	5
<b>Administrative:</b> Mitigation actions are easier to implement if the jurisdiction has the necessary staffing and funding.	1	2	3	4	5
<b>Political:</b> Mitigation actions can truly be successful if all stakeholders have been offered an opportunity to participate in the planning process and if there is public support for the action.	1	2	3	4	5
<b>Legal:</b> It is critical that the jurisdiction or implementing agency have the legal authority to implement and enforce a mitigation action.	1	2	3	4	5
<b>Economic:</b> Budget constraints can significantly deter the implementation of mitigation actions. It is important to evaluate whether an action is cost-effective, as determined by a cost benefit review, and possible to fund.	1	2	3	4	5
<b>Environmental:</b> Sustainable mitigation actions that do not have an adverse effect on the environment, comply with federal, state, and local environmental regulations, and are consistent with the community's environmental goals, have mitigation benefits while being environmentally sound.	1	2	3	4	5
<b>Score Total of All 7 Categories:</b>					

Page 2 of 5

2



1

**FIGURE: New Mitigation Action Worksheet (Page 3)**

Handout: New Mitigation Actions (LENOWISCO)

**Place an "X" by the hazard(s) this action will mitigate:**

Mitigated Hazard	
X	Place an "X" by the applicable hazard
	Communicable Disease
	Drought
	Earthquake
	Flooding
	Dam Failure
	Karst/Subsidence
	Landslide
	Non-Rotational Winds
	Solar Storm
	Tornado
	Wildfire
	Winter Storm

**Mitigation Action Timeline Parameters**

While the preference is to provide definitive project completion dates, this is impossible for every mitigation action. Therefore, the parameters for the timeline (**Projected Completion Date**) are as follows:

- **Short Term** = to be completed in 1 to 5 years
- **Long Term** = to be completed in greater than 5 years
- **Ongoing** = currently being funded and implemented under existing programs and is seeking funding and necessary approvals.

**Mitigation Action Estimated Cost**

While the preference is to provide definitive costs (dollar figures) for each mitigation action, this is not possible for every mitigation strategy/action. Therefore, the estimated costs for the mitigation initiatives identified in this Plan were identified as high, medium, or low, using the following ranges:

- **Low** – less than \$10,000
- **Medium** – from \$10,000 to \$100,000
- **High** – greater than \$100,000

**Mitigation Strategy/Action Prioritization Process**

The mitigation strategy must be prioritized according to a benefit/cost analysis of the proposed projects and their associated costs (44 CFR, Section 201.6(c)(3)(iii)). The mitigation strategies can be prioritized and evaluated, as shown on the individual mitigation action worksheets (using the **STAPLEE** method) for each recommended mitigation initiative.

County and municipal stakeholders evaluated each mitigation strategy/action with the following categories and questions.

**Social:**

2

3



1

**FIGURE: New Mitigation Action Worksheet (Page 4)**

Handout: New Mitigation Actions (LENOWISCO)

- Will the proposed action adversely affect one segment of the population?
- Will the action disrupt established neighborhoods, break up voting districts, or cause the relocation of lower-income people?

**Technical:**

- How effective is the action in avoiding or reducing future losses?
- Will it create more problems than it solves?
- Does it solve the problem or only a symptom?
- Does the mitigation strategy address continued compliance with the NFIP?

**Administrative:**

- Does the jurisdiction have the capability (staff, technical experts, and funding) to implement the action, or can it be readily obtained?
- Can the community provide the necessary maintenance?
- Can it be accomplished promptly?

**Political:**

- Is there political support to implement and maintain this action?
- Is there a local champion willing to help see the action to completion?
- Is there enough public support to ensure the success of the action?
- How can the mitigation objectives be accomplished at the lowest cost to the public?

**Legal:**

- Does the community have the authority to implement the proposed action?
- Are the proper laws, ordinances, and resolutions in place to implement the action?
- Are there any potential legal consequences?
- Is there any potential community liability?
- Is the action likely to be challenged by those who may be negatively affected?
- Does the mitigation strategy address continued compliance with the NFIP?

**Economic:**

- Are there currently sources of funds that can be used to implement the action?
- What benefits will the action provide?
- Does the cost seem reasonable for the size of the problem and likely benefits?
- What burden will be placed on the tax base or local economy to implement this action?
- Does the action contribute to other community economic goals such as capital improvements or economic development?
- What proposed actions should be considered but be "tabled" for implementation until outside funding sources are available?

**Environmental:**

- How will this action affect the environment (land, water, endangered species)?
- Will this action comply with local, state, and federal environmental laws and regulations?

2





1 *Meeting Three: Draft Plan Review*

2 [This section will be updated after the committee meeting.]

3

4 *Meeting Four: Final Plan & Adoption*

5 [This section will be updated after the committee meeting.]

6

DRAFT



1 Non-Participating Jurisdictions

2 All jurisdictions in the LENOWISCO Planning District were invited multiple times through phone  
 3 calls and e-mails to participate in the plan update. The jurisdictions that did not participate are  
 4 listed below. All the non-participating jurisdictions fall within counties that did participate in the  
 5 plan update. The counties have a larger staffing capacity to support mitigation projects.

**TABLE: Non-Participating Jurisdictions**

Jurisdiction	Planning Meeting Invitations Sent via E-mail	Phone Call Dates Contacted	Responses & Reasons
Town of Jonesville	9/29/20, 10/7/20, 12/15/20	12/1/20, 12/8/20, 12/15/20, 1/13/21, 1/22/21	Non-responsive; County incorporated hazards impacting the jurisdiction into their plan
Town of St. Charles	9/29/20, 10/7/20, 12/15/20	12/8/20, 1/13/21	No Government; Relies on County; County incorporated hazards impacting the jurisdiction into their plan
Town of Clinchport	9/29/20, 10/7/20, 12/15/20	12/8/20, 1/13/21	No Staff; Relies on County; County incorporated hazards impacting the jurisdiction into their plan
Town of Duffield	9/29/20, 10/7/20, 12/15/20	12/8/20, 1/13/21	No Staff; Relies on County; County incorporated hazards impacting the jurisdiction into their plan
Town of Dungannon	9/29/20, 10/7/20, 12/15/20	12/1/20, 12/8/20, 12/15/20, 1/13/21, 1/22/21, 1/28/21	Non-responsive; County incorporated hazards impacting the jurisdiction into their plan
Town of Nickelsville	9/29/20, 10/7/20, 12/15/20	12/1/20, 12/8/20, 12/15/20, 1/13/21, 1/22/21	No Full-time Staff; Relies on County
Town of Weber City	9/29/20, 10/7/20, 12/15/20	12/1/20, 12/8/20, 12/15/20, 1/13/21, 1/22/21	Non-responsive; County incorporated hazards impacting the jurisdiction into their plan
Town of Appalachia	9/29/20, 10/7/20, 12/15/20	12/1/20, 12/8/20, 12/15/20, 1/13/21, 1/22/21	Non-responsive; County incorporated hazards impacting the jurisdiction into their plan

6



## 1 Community Preparedness Survey

2 The LENOWISCO Planning District distributed an online, public survey to residents from  
3 December 17, 2020 to February 1, 2021. There were 166 complete responses, representing all  
4 of the participating jurisdictions. The survey included 35 questions (detailed in Appendix A:  
5 Survey Questions) and concluded with mitigation and preparation resources available in the  
6 District. A complete report of survey results is available in Appendix A: Survey Results.

7 The survey was shared by members of the planning committee across multiple platforms in the  
8 District, including:

- 9 • Nextdoor
- 10 • LENOWISCO Planning District website
- 11 • LENOWISCO Planning District social media (Twitter)
- 12 • Jurisdiction websites
- 13 • Jurisdiction social media platforms (Facebook, Twitter)
- 14 • Virginia Star newspaper

15 The press release along with samples of survey distribution methods is available in Appendix A.

## 16 *Regional Representation*

17 Residents from each of the participating jurisdictions in the LENOWISCO Planning District  
18 responded to the survey, with 22.8% indicating they lived or worked in Lee County, 24.7% in  
19 Scott County, 53.3% in Wise County, and 7.3% in Norton. The Town of Wise (Wise County),  
20 Town of Gate City (Scott County), and Town of Big Stone Gap (Wise County) had the most  
21 survey respondents outside of unincorporated county areas. Survey responses by participating  
22 jurisdiction are detailed below:

- 23 • Town of Wise (40 responses)
- 24 • Unincorporated Wise County (37 responses)
- 25 • Unincorporated Lee County (29 responses)
- 26 • Town of Gate City (27 responses)
- 27 • Unincorporated Scott County (19 responses)
- 28 • Town of Big Stone Gap (18 responses)
- 29 • City of Norton (15 responses)
- 30 • Town of Pennington Gap (13 responses)
- 31 • Town of Coeburn (11 responses)
- 32 • Town of St. Paul (8 responses)
- 33 • Town of Pound (4 responses)

## 34 *Demographics and Household Characteristics*

35 The breakdown of survey participants mirrored the regional population, as described in the  
36 demographics section (1.5.3).

- 37 • 96.4% of survey respondents identify as Non-Hispanic White and 98.8% speak English  
38 in their household.
- 39 • 85% of respondents own their homes and 12% are renters.





- 1 • 24% of survey respondents live in a mobile or manufactured home, and 70% live in a
- 2 single-detached home.
- 3 • 71% of respondents have lived in the LENOWISCO Planning District for 21 years or
- 4 more, with only 14% having lived in the region for 10 years or less.

## 5 *Natural Hazard Rankings*

6 Survey respondents indicated the risk level for each hazard affecting the LENOWISCO Planning  
7 District. The hazards are organized by the number of respondents who indicated "high risk"  
8 below. Respondents indicated that Winter Storm and Communicable Disease were by far the  
9 highest-ranked hazards. This is understandable given this plan update took place during the  
10 COVID-19 global pandemic. Overall, 44.7% of survey respondents believed that the risks  
11 associated with the LENOWISCO Planning District's most prevalent hazards were increasing.

- 12 • Winter Storm (52.0%)
- 13 • Communicable Disease (41.5%)
- 14 • Flooding (18.1%)
- 15 • Wildfire (15.1%)
- 16 • Landslide (6.4%)
- 17 • Drought (5.3%)
- 18 • Tornado (5.3%)
- 19 • Subsidence (4.8%)
- 20 • Earthquake (4.7%)
- 21 • Karst (3.0%)
- 22 • Dam Failure (2.3%)
- 23 • Solar Storm (1.8%)

24 Survey respondents ranked the priority for mitigation of each hazard, based on their own risk  
25 perception. Ranking of priorities closely mirrored risk rankings, but more survey respondents  
26 believed their jurisdiction should more heavily prioritize flood mitigation than believed it was a  
27 high risk. Similarly, more respondents indicated a high priority to mitigate communicable  
28 disease, taking the top position of the surveyed hazards.

- 29 • Communicable Disease (54.5%)
- 30 • Winter Storm (51.5%)
- 31 • Flooding (35.5%)
- 32 • Wildfire (21.6%)
- 33 • Tornado (14.5%)
- 34 • Landslide (13.3%)
- 35 • Dam Failure (7.8%)
- 36 • Subsidence (7.4%)
- 37 • Non-Rotational Winds (7.2%)
- 38 • Drought (5.4%)
- 39 • Earthquake (5.4%)
- 40 • Solar Storm (3.0%)
- 41 • Karst (2.4%)

42



1 **Preparation, Response, and Recovery**

2 The survey asked respondents to describe their personal preparedness, how they access  
3 information about emergencies, their ability and willingness to evacuate in case of a natural  
4 hazard event, and their ability to successfully recover from a disaster.

5 **Communication and Information**

- 6 • 93% of survey respondents use a cellphone to access the internet, followed by 85% who  
7 use a computer or laptop at home. One respondent noted they do not have access to  
8 the internet, but this is likely an underestimate as the survey was only distributed online.
- 9 • Survey respondents noted their top sources for emergency and disaster preparedness  
10 information were web searches (42.4%), social media (37.6%), and Virginia government  
11 websites (37.1%).
- 12 • When asked how they would expect to receive alerts and information during an  
13 emergency, respondents indicated local television media (59.3%), private weather apps  
14 like the Weather Channel (54.1%), and social media (45.5%) as their top sources.
- 15 • 58% of respondents agreed or strongly agreed that they can easily obtain emergency  
16 information in times of crisis, while 14% disagreed or strongly disagreed.

17 **Preparedness**

- 18 • The top activities individuals have done to prepare for emergencies and disasters are to  
19 sign-up for emergency alerts (38.5%), secure a weather radio (29.1%), and prepare a  
20 72-hour kit or disaster supply kit (27.7%). More than a quarter of respondents noted they  
21 had "done nothing" to prepare for an emergency.
- 22 • In selecting the reasons they have not pursued additional preparedness activities, 26.7%  
23 of survey respondents noted they didn't know what to do, followed by 15% of  
24 respondents who said it cost too much.
- 25 • If a disaster (e.g., snowstorm) impacted their community, knocking out electricity and  
26 running water, 68% of survey respondents thought their household could manage on its  
27 own for at least 3 days.
- 28 • 39.7% of respondents agreed or strongly agreed that their jurisdiction is providing the  
29 services necessary to prepare them for a disaster, while 20.5% disagreed or strongly  
30 disagreed.

31 **Evacuation**

- 32 • 80.2% of survey respondents indicated they were very likely or somewhat likely to  
33 immediately evacuate as instructed. 5% of respondents indicated they were at least  
34 somewhat likely to refuse to evacuate at all.
- 35 • When asked what would prevent them from evacuating, survey respondents indicated  
36 that a pet (35.3%), needing to stay to protect property (26.3%), and not having a place to  
37 go (21.6%) were the top reasons. An additional 27.5% of respondents indicated that no  
38 obstacles would prevent their evacuation.
- 39 • 6% of respondents indicated that someone in their household would require special  
40 assistance in an evacuation, and an additional 11% indicated that someone might need  
41 assistance. Out of the individuals that indicated yes or maybe, 11% didn't know who  
42 would provide the assistance, and 19% of respondents would rely on an outside agency.



1 **Recovery**

2 The top reasons for possibly not being able to recover from a disaster were no alternative power  
3 supply (46.3%), lack of financial savings (39.3%), or disruption in employment (26.9%).

4 *Personal Disaster Experience*

5 When asked if they had experienced any damage(s) from a previous disaster, 48.5% of survey  
6 respondents had experienced minor property damage and loss, while 11.2% had experienced  
7 major or catastrophic property damage. When asked what hazard caused the damages or  
8 losses, the most common answers included windstorms, winter storms, and flooding events, as  
9 illustrated in the word cloud below.

10 **FIGURE: Word Cloud based on Survey Response Answers**



11

12



1 Public Forums and Outreach

2 [A description and findings from the February 18, 2021 meeting will be included here.]

3

DRAFT



1 Public Plan Review and Feedback

2 At the conclusion of the planning process, the public was offered an opportunity to provide  
3 feedback to the draft plan. Efforts to make this opportunity known to residents included the  
4 following:

- 5 • Posting to the LENOWISCO Planning District website, as well as participating  
6 jurisdiction websites
- 7 • Sharing the link to the draft plan via social media platforms, including posting to  
8 Nextdoor and Facebook
- 9 • Announcements in the local newspaper

10 Critical feedback from the public was provided by members of the public throughout the entire  
11 planning process. Members of the public attended public meetings and followed up with  
12 feedback particularly regarding mitigation actions, environmental concerns, and future  
13 development ideas.

14 [More detail on the public plan review process and feedback will be included here after the  
15 public review period (February 12-26, 2021) is completed.]

16

DRAFT



## 1 Section 1.5 Community Profile

2 This profile will describe the LENOWISCO Planning District as a whole. For community profiles  
3 specific to each jurisdiction, please see the community annexes.

### 4 1.5.1 Topography, Geography, and Geology

5 There are 23 Planning District Commissions (PDC) in Virginia. The LENOWISCO Planning  
6 District Commission is the westernmost of all PDCs within the Commonwealth of Virginia. The  
7 District stretches roughly 1,385 square miles, bound on the north and west by the State of  
8 Kentucky, on the south by the State of Tennessee, and on the east by the Virginia counties of  
9 Dickenson, Russell, and Washington.

10 **FIGURE: Virginia Planning District Commissions**  
11 **Source: [Virginia Department of Housing and Community Development](#)**

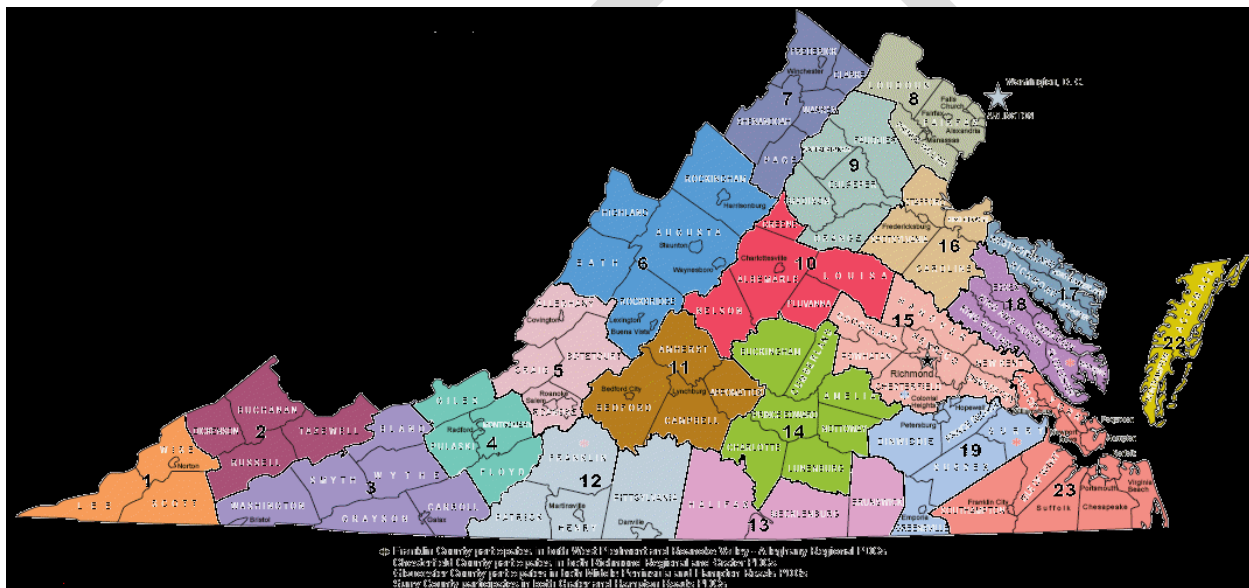

12  
13 The LENOWISCO Planning District includes the four major jurisdictions of Lee County, Scott  
14 County, Wise County, the City of Norton, as well as 15 additional jurisdictions.

- 15 • **Lee County** is the westernmost county in the U.S. Commonwealth of Virginia and had  
16 an estimated population of 34,134 in 2018 according to American Community Survey  
17 (ACS) estimates. The county seat of Lee County is Jonesville. Additional incorporated  
18 communities include Pennington Gap and St. Charles.
- 19 • **Scott County** is directly east of Lee County and according to 2018 ACS estimates has a  
20 population of 22,009. The county seat is Gate City, and additional communities include  
21 Clinchport, Duffield, Dungannon, Nickelsville, and Weber City.
- 22 • **Wise County** is directly northeast of Lee County and according to 2018 ACS estimates  
23 has a population of 39,025. The county seat is Wise, and additional communities include  
24 Appalachia, Big Stone Gap, Coeburn, Pound, St. Paul, and the independent City of  
25 Norton.





- 1 • **Norton** is an independent city in the Commonwealth of Virginia. According to 2018 ACS  
2 estimates, the City's population is 3,990, making it the least populous city in Virginia,  
3 along with the westernmost. Please note that the Bureau of Economic  
4 Analysis combines the City of Norton with surrounding Wise County for statistical  
5 purposes.

6 **FIGURE: LENOWISCO Planning District Jurisdictions**

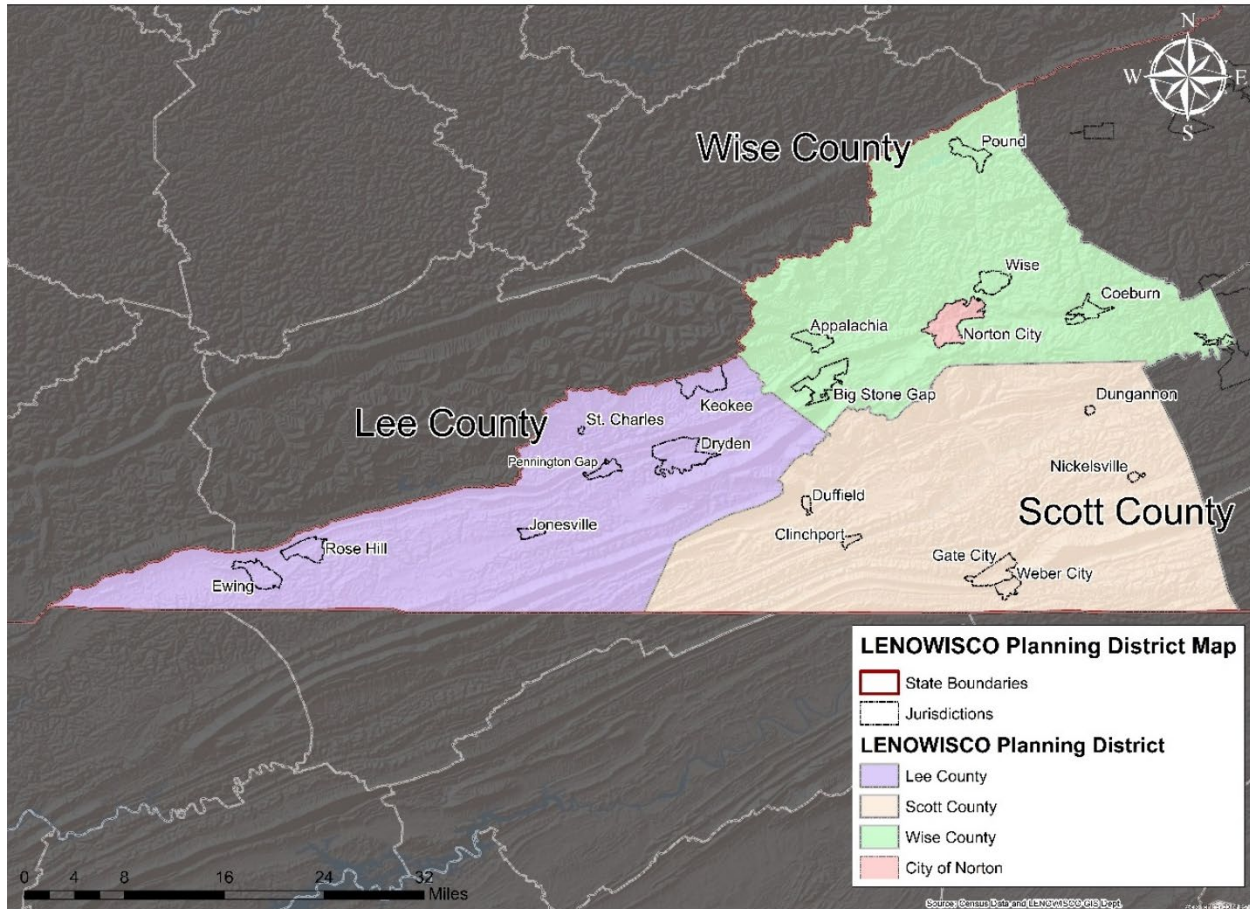

7  
8

9 **District Topography**

10 Terrain and climate have determined the nature of the state's agriculture and industries. To help  
11 understand this setting that has been critical to life in Virginia for thousands of years,  
12 geographers have identified five physical regions in the state: the Coastal Plain (Tidewater),  
13 Piedmont, Blue Ridge Mountains, Valley and Ridge, and Appalachian Plateau. The  
14 LENOWISCO Planning District stretches both the Appalachian Plateau and Valley & Ridge  
15 regions. Lee and Scott Counties are primarily located in Valley & Ridge, while Wise County is  
16 primarily located within the Appalachian Plateau.

17



1  
2

**FIGURE: Physiographic Provinces of Virginia**  
 Source: Adapted from C.M. Bailey and Chad Roberts, 1999

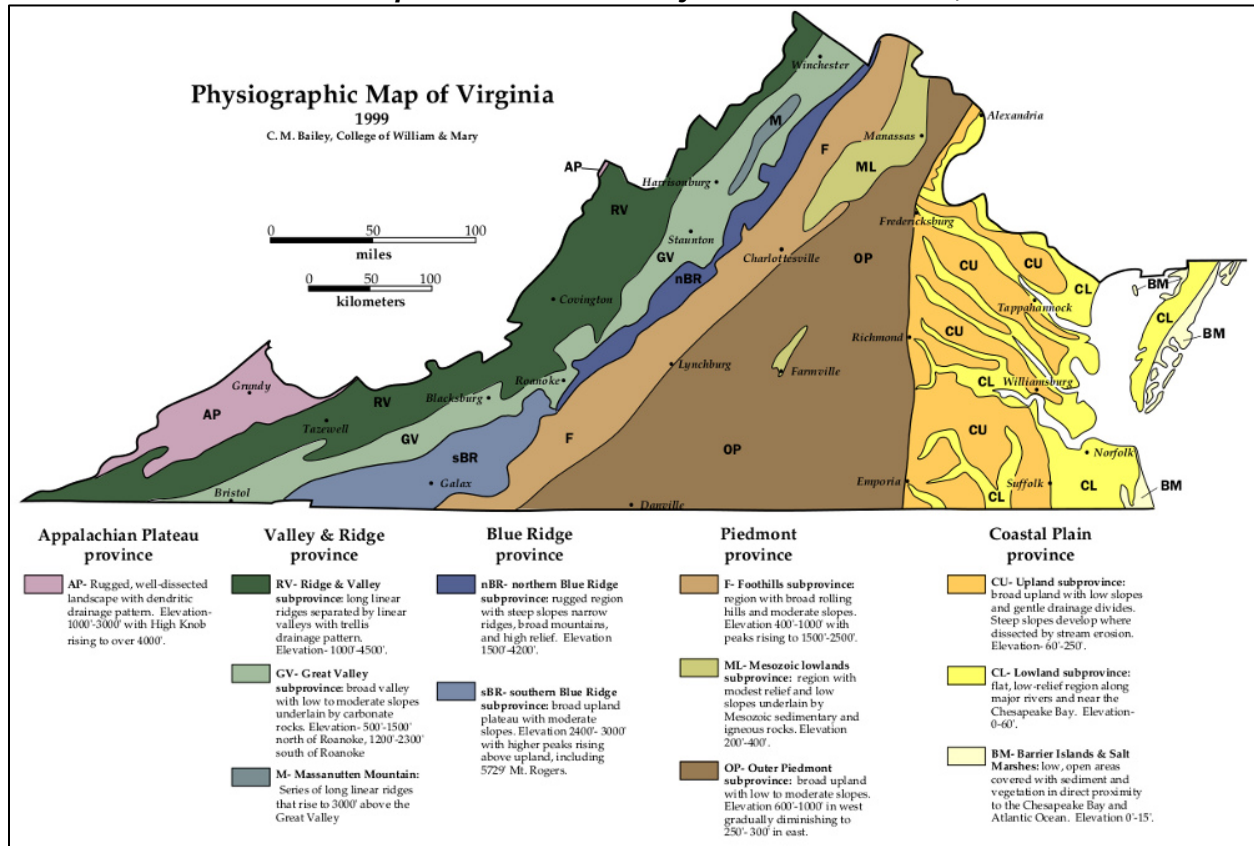

3

- 4 • **Appalachian Valley & Ridge Province:** Extending southwest to northeast along

5 Virginia's western border is the Appalachian Ridge and Valley Region. Sometimes called

6 the Great Valley, the region is a series of valleys divided by mountains. The region

7 ranges from 1,000 ft. valleys to 4,000 ft. peaks. The region is characterized by its lush

8 and gentle valleys and limestone caverns, caves, and hot springs.
- 9 • **Appalachian Plateau:** In the far southwestern portion of Virginia lies the Appalachia

10 Plateau. This plateau extends into Kentucky as the Cumberland Plateau. Covered with

11 rivers, streams, and forests, the Appalachian Plateau averages about 2,000 feet above

12 sea level. Only three counties sit within the plateau, including Wise County. It is not a

13 mountain range, but rather an eroded plain of sedimentary rock. The region is

14 characterized by hilly and rugged terrain, stream erosion, and many valleys. The region

15 is covered in forests and is home to many coal, natural gas, and petroleum resources.

16 **District Geology**

- 17 • **Appalachian Valley & Ridge Province:** Most of Scott County and Lee County fall

18 within the Appalachian Valley & Ridge province, made up of limestone, shale, and

19 sandstone. The presence of limestone bedrock leads to sinkholes across the region due

20 to underground drainage and unstable rock formations. Additionally, the area has

21 shallow soil underlain by these large rock formations, limiting many types of

22 development at the surface.





1       • **Appalachian Plateau:** Much of Wise County, as well as the northern portion of Lee  
2       County (St. Charles area), fall within the Appalachian Plateau region. This area features  
3       sedimentary rocks in alternating beds of including sandstone, shale, coal, dolomite, and  
4       limestone. Much of the region features mineral deposits beneath the surface, often  
5       leading to divergent mineral and surface land ownership and rights. Underground mining  
6       operations can lead to unstable and subsiding surface conditions. This portion of the  
7       region has some of the most severe physical constraints to development.

8       There are no superfund sites in the LENOWISCO Planning District. There are areas in the  
9       District that were heavily utilized for coal mining; however, the Environmental Protection Agency  
10      has not declared any site in the planning distracted to be contaminated to a Superfund level  
11      ([EPA](#)).

12

DRAFT



## 1 1.5.2 Climate

2 The Commonwealth of Virginia is home to five, diverse climate regions: the Tidewater,  
3 Piedmont, Northern Virginia, Western Mountain, and Southwestern Mountain regions. The  
4 climate is the result of global weather patterns and the diverse landscape of the state, including  
5 the warm waters of the Atlantic Ocean Gulf Stream, the Blue Ridge Mountains, and the state's  
6 extensive and complex network of rivers and streams. The rivers drain in all four geographical  
7 directions. In the Southwestern Mountain region, where the LENOWISCO Planning District is  
8 located, the Clinch and Holston rivers drain into North Carolina and Tennessee. Air flows up  
9 these river valleys or down into the valleys from the mountains, impacting rainfall and air  
10 moisture. The concentration of different climate regions within a relatively small area leads to  
11 inconsistency in regional climate from year to year due to the lack of fixed boundaries between  
12 regions.

13 Frontal weather systems in Virginia tend to move from west to east. When cold air from the west  
14 or northwest enters Virginia, it often causes heavy snowfall as a frontal storm. Thunderstorms  
15 can occur at any time of year in Virginia but are more common in the summer with moist, warm  
16 air. Thunderstorms are most frequent in the southern part of the state, especially in the  
17 Southwestern Mountain region. Hurricanes and tropical storms form over warm ocean waters in  
18 lower latitudes. Once they reach the mid-latitudes, they tend to curve northerly and intensify.  
19 These storms mostly affect the Virginia Region between early August and September  
20 ([University of Virginia Climatology Office](#)).

21 Southwestern Mountain region experiences some of the most extreme weather in the  
22 Commonwealth, including frequent thunderstorm days, high snowfall, and high annual rainfall.  
23 While the far inland location of the District protects it from the worst of tropical systems, the  
24 region still experiences a great deal of potentially hazardous weather. The following data are  
25 annual averages for the Southwestern Mountain Climate Region ([Virginia](#)):

- 26 • January Average Temperature: 24-44 (F)
- 27 • July Average Temperature: 60-85 (F)
- 28 • January Average Precipitation 4.04 inches
- 29 • July Average Precipitation 4.73 inches
- 30 • Annual Precipitation 47.33 inches
- 31 • Average Annual Snowfall: 16.7 to 23.2 inches

32 The climate between communities in the LENOWISCO Planning District can vary greatly  
33 depending on geographic location. For example, the Town of Wise in Wise County sees an  
34 average annual snowfall of 52 inches, while nearby Big Stone Gap sees only an average of  
35 eight inches of snow each year. The charts below illustrate the average annual rainfall and  
36 temperature for three locations in the District.

37



1  
2

**TABLE: Average Rainfall and Temperature in Wise, Virginia**  
 Source: *US Climate Data*

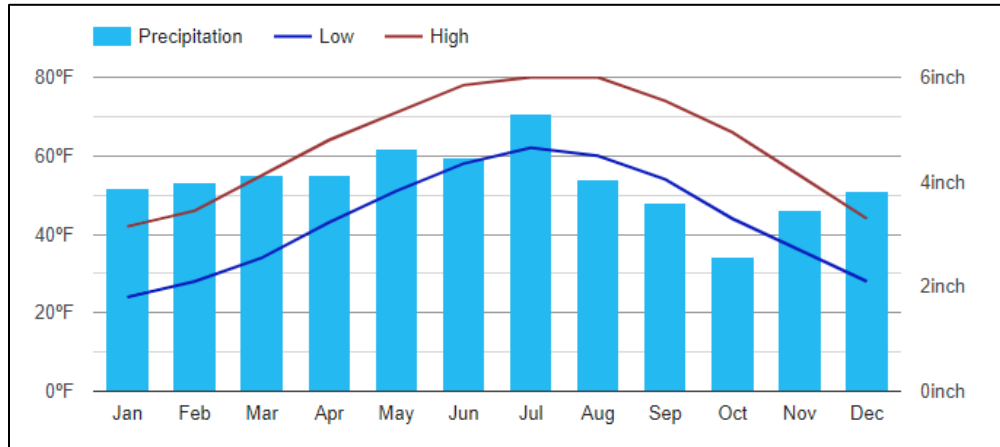

3  
4  
5

**TABLE: Average Rainfall and Temperature in Big Stone Gap, Virginia**  
 Source: *US Climate Data*

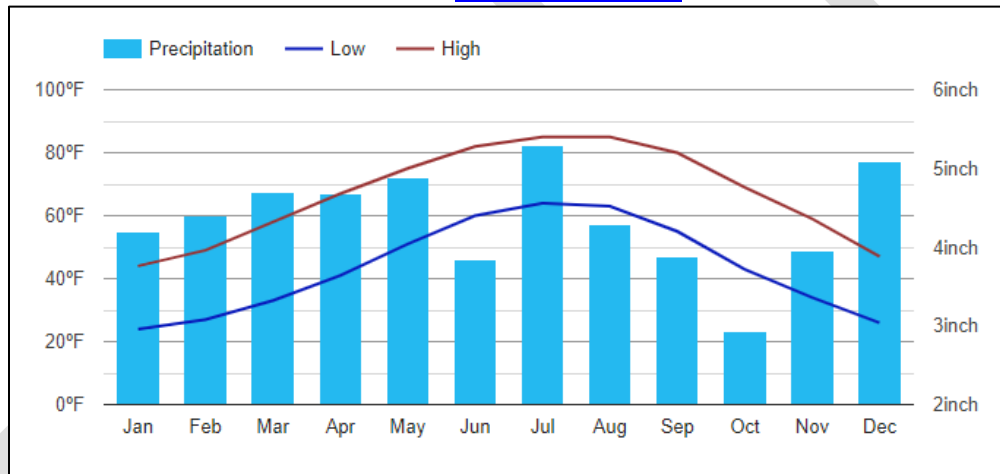

6  
7  
8  
9

**TABLE: Average Rainfall and Temperature in Pennington Gap, Virginia**  
 Source: *US Climate Data*

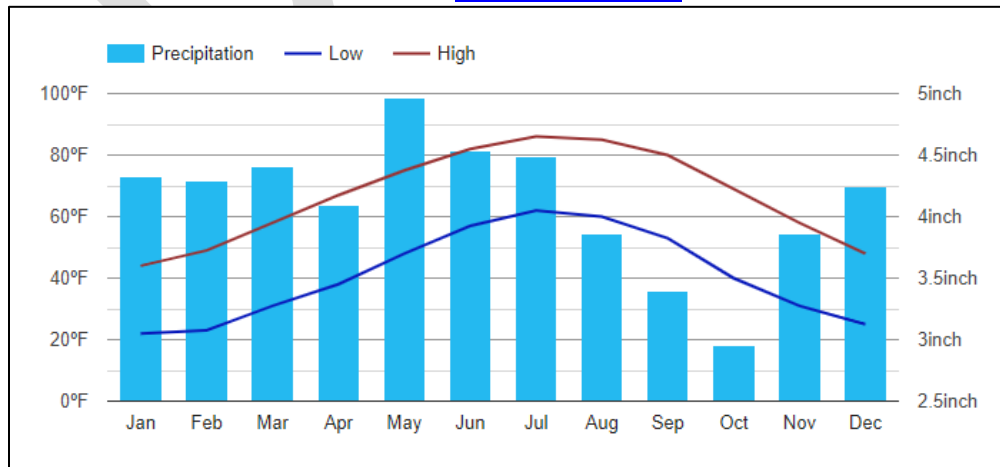

10



### 1 1.5.3 Demographics

2 The following section provides a summary of the demographics of residents in the LENOWISCO  
3 Planning District, including population estimates, age, educational attainment, race and  
4 ethnicity, community patterns, poverty levels, and additional data relevant to community  
5 resilience.

#### 6 Population

7 The following demographic data is based on the 2018 American Community Survey 5-Year  
8 Estimates for the four jurisdictions included in the LENOWISCO Planning District. The total  
9 population of the District was estimated to be 89,158 people as of 2018, with 3,990 people in  
10 the City of Norton, 24,134 people in Lee County, 22,009 people in Scott County, and 39,025  
11 people in Wise County.

12 The Demographics Research Group at the University of Virginia Weldon Cooper Center is  
13 responsible for providing official statewide population projections for each biennial. According to  
14 these projections, included in the table below, the District's population will remain relatively  
15 constant through 2040, with some reduction in population projected.

<b>TABLE: Population Projections</b>			
<i>Source: Demographics Research Group, UVA Weldon Cooper Center</i>			
<b>Jurisdiction</b>	<b>2020 Projection</b>	<b>2030 Projection</b>	<b>2040 Projection</b>
City of Norton	3,906	3,857	3,762
Lee County	23,718	23,632	23,258
Scott County	21,949	20,961	19,740
Wise County	37,844	36,400	34,545

16



- 1 Age
- 2 The following table shows the distribution of ages throughout the LENOWISCO Planning District compared to the U.S. and Virginia
- 3 as a whole. Each county in the district has a slightly higher median age, with Scott County as the oldest jurisdiction with a median
- 4 age of 46.9 years. The age distribution is similar to the makeup of both Virginia and the United States, with a similar proportion of
- 5 both children and older adults.

**TABLE: Community Profile – Age**  
**Source: 2018 American Community Survey 5-Year Estimates**

Age	United States	Virginia	City of Norton		Lee County		Scott County		Wise County	
			Estimate	Percent	Estimate	Percent	Estimate	Percent	Estimate	Percent
Median Age	37.9 years	38.5 years	37.3 years		44.4 years		46.9 years		40.7 years	
Under 5 Years	6.1%	6.1%	316	7.9%	1,123	4.7%	885	4.0%	2,013	5.2%
5 to 9 years	6.3%	6.2%	234	5.9%	1,272	5.3%	1,018	4.6%	2,331	6.0%
10 to 14 years	6.4%	6.2%	238	7.0%	1,340	5.6%	1,386	6.3%	2,042	5.2%
15 to 19 years	6.6%	6.5%	128	3.2%	1,254	5.2%	1,209	5.5%	2,344	6.0%
20 to 24 years	6.9%	6.9%	205	5.1%	1,171	4.9%	1,070	4.9%	2,702	6.9%
25 to 34 years	13.8%	13.9%	608	15.2%	3,112	12.9%	2,362	10.7%	5,348	13.7%
35 to 44 years	12.6%	13.0%	509	12.8%	3,045	12.6%	2,573	11.7%	4,882	12.5%
45 to 54 years	13.1%	13.8%	378	9.5%	3,384	14.0%	3,147	14.3%	5,200	13.3%
55 to 59 years	6.7%	6.7%	351	8.8%	2,047	8.5%	2,498	6.8%	2,670	6.8%
60 to 64 years	6.1%	6.0%	291	7.3%	1,672	6.7%	1,862	8.5%	2,910	7.5%
65 to 74 years	8.9%	8.7%	401	10.1%	2,844	11.8%	2,814	12.8%	3,959	10.1%
75 to 84 years	4.4%	4.2%	241	6.0%	1,576	6.5%	1,699	7.7%	1,776	4.6%
85 years and over	1.9%	1.7%	47	1.2%	339	1.4%	486	2.2%	848	2.2%



1 Educational Attainment

2 The following table shows the educational attainment for individuals 25 and over in the LENOWISCO Planning District when  
 3 compared to the U.S. and Virginia. Overall, educational attainment in the district is lower than in Virginia and the U.S. All jurisdictions  
 4 in the district have a lower percentage of high school graduates or higher, ranging from 74.8% in Wise County to 81.2% in Scott  
 5 County. As of 2018, 10% of people over 25 in Lee County and Wise County had not completed at least 9th grade. Similarly, a smaller  
 6 percentage of people in the district have completed a bachelor's degree or higher, with rates at less than half of the national and  
 7 state totals.

**TABLE: Community Profile - Educational Attainment**  
**Source: 2018 American Community Survey 5-Year Estimates**

Educational Attainment	United States	Virginia	City of Norton		Lee County		Scott County		Wise County	
			Estimate	Percent	Estimate	Percent	Estimate	Percent	Estimate	Percent
Less than 9th grade	4.8%	3.8%	139	4.9%	1,836	10.2%	1,302	7.9%	2,760	10.0%
9th to 12th grade, no diploma	6.6%	6.2%	405	14.3%	2,534	14.1%	1,796	10.9%	4,186	15.2%
High school graduate	26.9%	23.6%	690	24.4%	6,086	33.9%	6,115	37.2%	8,459	30.7%
Some college, no degree	20.0%	18.9%	848	30.0%	4,196	23.3%	3,560	21.7%	5,862	21.2%
Associate's degree	8.6%	8.0%	266	9.4%	1,281	7.1%	1,305	7.9%	2,319	8.4%
Bachelor's degree	20.3%	22.4%	320	11.3%	1,477	8.2%	1,574	9.6%	2,451	8.9%
Graduate or professional degree	12.8%	17.2%	158	5.6%	564	3.1%	789	4.8%	1,556	5.6%
High school graduate or higher	88.6%	90.0%	2,282	80.8%	13,604	75.7%	13,343	81.2%	20,647	74.8%
Bachelor's degree or higher	33.1%	39.6%	478	16.9%	2,041	11.4%	2,363	14.4%	4,007	14.5%

8  
 9



1 Race/Ethnicity

2 The following table shows the distribution of the population that is White alone and Black or African American alone within the  
 3 LENOWISCO Planning District when compared with Virginia and the U.S. Other race/ethnicity data is excluded as the groups are  
 4 well under 1% when included by jurisdiction. As the largest racial minority group in the district, the Black/African American population  
 5 is small, making up between 0-5.7% across the jurisdictions. The proportion of Black/African Americans in the district remains quite  
 6 low compared to both Virginia as a whole (19.4%) and the United States (12.8%).

**TABLE: Community Profile - Race/Ethnicity**  
**Source: 2018 American Community Survey 5-Year Estimates**

Race/Ethnicity	United States		Virginia		City of Norton		Lee County		Scott County		Wise County	
	Estimate	Percent	Estimate	Percent	Estimate	Percent	Estimate	Percent	Estimate	Percent	Estimate	Percent
White alone	236,475,401	72%	5,714,646	67.0%	3,597	90.2%	22,551	93.4%	21,566	98.0%	35,998	92%
Black or African American alone	41,989,671	12.8%	1,659,908	19.4%	185	4.6%	1,033	4.3%	162	<1%	2,227	5.7%

8 Commuting Patterns

9 The following tables show the commuting patterns of residents of the LENOWISCO Planning District by both means of transportation  
 10 and place of work. Due to the District's location at the southwest corner of Virginia, bordering Tennessee and Kentucky, a  
 11 disproportionate number of residents commute out of the state for work, when compared with Virginia and the United States as a  
 12 whole. This is especially true for residents of Scott County, where more than 50% of working residents are estimated to commute out  
 13 of state. Many workers also commute outside of their county, but within Virginia, for work. Additionally, LENOWISCO Planning  
 14 District workers overwhelmingly rely on personal transportation, specifically personal cars, for commuting.

**TABLE: Community Profile - Commuting Pattern**  
**Source: 2018 American Community Survey 5-Year Estimates**

Means of Transportation	United States	Virginia	City of Norton	Lee County	Scott County	Wise County
Drove alone	76.4%	77.2%	96.1%	84.2%	87.1%	83.7%
Carpooled	9.1%	9.2%	3.0%	10.5%	8.6%	11.2%
Other (public transit, walk, bike, work from home, etc.)	14.5%	13.6%	0.9%	5.2%	4.2%	5.1%





TABLE: Community Profile - Commuting Patterns  
 Source: 2018 American Community Survey 5-Year Estimates

Place of Work	United States	Virginia	City of Norton	Lee County	Scott County	Wise County
Worked in <b>county</b> of residence	72.3%	48.4%	21.4%	53.0%	38.7%	78.2%
Worked outside of <b>county</b> of residence	24.0%	42.8%	70.5%	26.4%	10.6%	16.8%
Worked outside of <b>state</b> of residence	3.7%	8.8%	8.1%	20.7%	50.7%	4.9%

Poverty

The following table shows the 2019 data produced by the [Small Area Income and Poverty Estimates Program](#), which produces single-year estimates of income and poverty by county. The data for 2019 demonstrates a slight decrease in individuals residing in poverty in the LENOWISCO Planning District (compared to the ACS 5-Year Estimates from 2018 presented in the next table); however, the 2020 COVID-19 Pandemic prompted an increase in the poverty rate across the US. The [CDC](#) further studies the association between social vulnerability and a county's risk of becoming a hotspot. The data, to the extent available, will be further analyzed in the hazard profiles.

TABLE: Community Profile - Poverty  
 Source: 2019 Small Area Income and Poverty Estimates (SAIPE) Program

Poverty	United States		Virginia		City of Norton		Lee County		Scott County		Wise County	
	Estimate	Percent	Estimate	Percent	Estimate	Percent	Estimate	Percent	Estimate	Percent	Estimate	Percent
Living in poverty	39,490,096	12.3%	822,944	9.9%	756	19.3%	5,939	27.1%	3,069	14.8%	7,039	20.4%





1 Additional Data

2 The following table outlines a number of other important indicators of community resilience. Across several indicators, residents of  
 3 the District may be more vulnerable to natural hazard events. In addition to higher poverty levels than the U.S. and Virginia as a  
 4 whole, the population of the District also tends to be older and more likely to have a disability. Additionally, many LENOWISCO  
 5 Planning District residents live in vulnerable housing - with four times as many households living in mobile homes as the national  
 6 average. It is important to note that the American Community Survey (ACS) estimates have a significant margin of error for smaller  
 7 jurisdictions due to survey sample size limitations. This is especially true for very narrow community groups. ACS data was confirmed  
 8 with local stakeholders to reach the best possible population estimates.

**TABLE: Community Resilience Profile**  
**Source: 2018 American Community Survey 5-Year Estimates**

Community Resilience Indicator	United States		Virginia		City of Norton		Lee County		Scott County		Wise County	
	Estimate	Percent	Estimate	Percent	Estimate	Percent	Estimate	Percent	Estimate	Percent	Estimate	Percent
People with disabilities	40,071,666	12.6%	954,220	11.6%	929	23.6%	5,859	25.9%	5,286	24.8%	9,886	26.9%
People who are unemployed	9,508,312	3.7%	217,670	3.2%	247	7.9%	861	4.3%	491	2.7%	1,327	4.1%
People living below the poverty level	44,257,979	14.1%	893,580	10.9%	1,155	29.4%	5,414	24.0%	3,923	18.6%	7,890	22.0%
Households that receive SNAP Benefits	14,635,287	12.2%	371,719	8.7%	629	34.6%	2,248	24.6%	1,467	16.7%	3,394	22.4%
People without health insurance	29,752,767	9.4%	755,739	9.2%	397	35.6%	2,981	13.2%	2,320	10.9%	4,082	11.1%
People 65 years and older	50,783,796	15.6%	1,271,946	15%	689	14.2%	4,759	19.7%	4,999	22.7%	6,583	16.9%
People under 18 years old	73,429,392	22.6%	1,865,699	22.1%	923	25.6%	4,580	19%	4,062	18.5%	7,755	19.9%
Number of mobile homes in the community	8,512,218	6.2%	180,297	5.2%	309	15.1%	2,583	21.9%	2,991	25.9%	4,976	27.7%
Number of homes built in 1939 or earlier	17,407,947	12.8%	261,767	7.5%	233	11.4%	1,339	11.4%	1,606	13.5%	2,096	11.7%
Number of housing units without access to a vehicle	10,424,934	8.7%	194,930	6.2%	224	12.3%	989	10.8%	680	7.8%	1,521	10.1%



## 1 1.5.4 Economy

2 The following section provides data relevant to the economic conditions of the LENOWISCO  
3 Planning District, including unemployment rates, local industry, and income and wage trends.

### 4 Unemployment Rates

5 The LENOWISCO Planning District, as with much of the United States, had a low  
6 unemployment rate for several years prior to the onset of the 2020 COVID-19 Pandemic. As  
7 shown in the table below, unemployment rates steadily decreased in the District after 2013,  
8 reaching a low of 3.6% in November 2019. In 2020, unemployment rates across the country  
9 rose, with a peak in April. As of September 2020, the LENOWISCO economy seems to be  
10 returning to a more stable unemployment rate, but as the pandemic is ongoing, it is unclear if  
11 this trend will continue into 2021.

12 **FIGURE: Unemployment Rates for LENOWISCO Planning District**  
13 **Source: Virginia Employment Commission, 2nd Quarter, 2020**

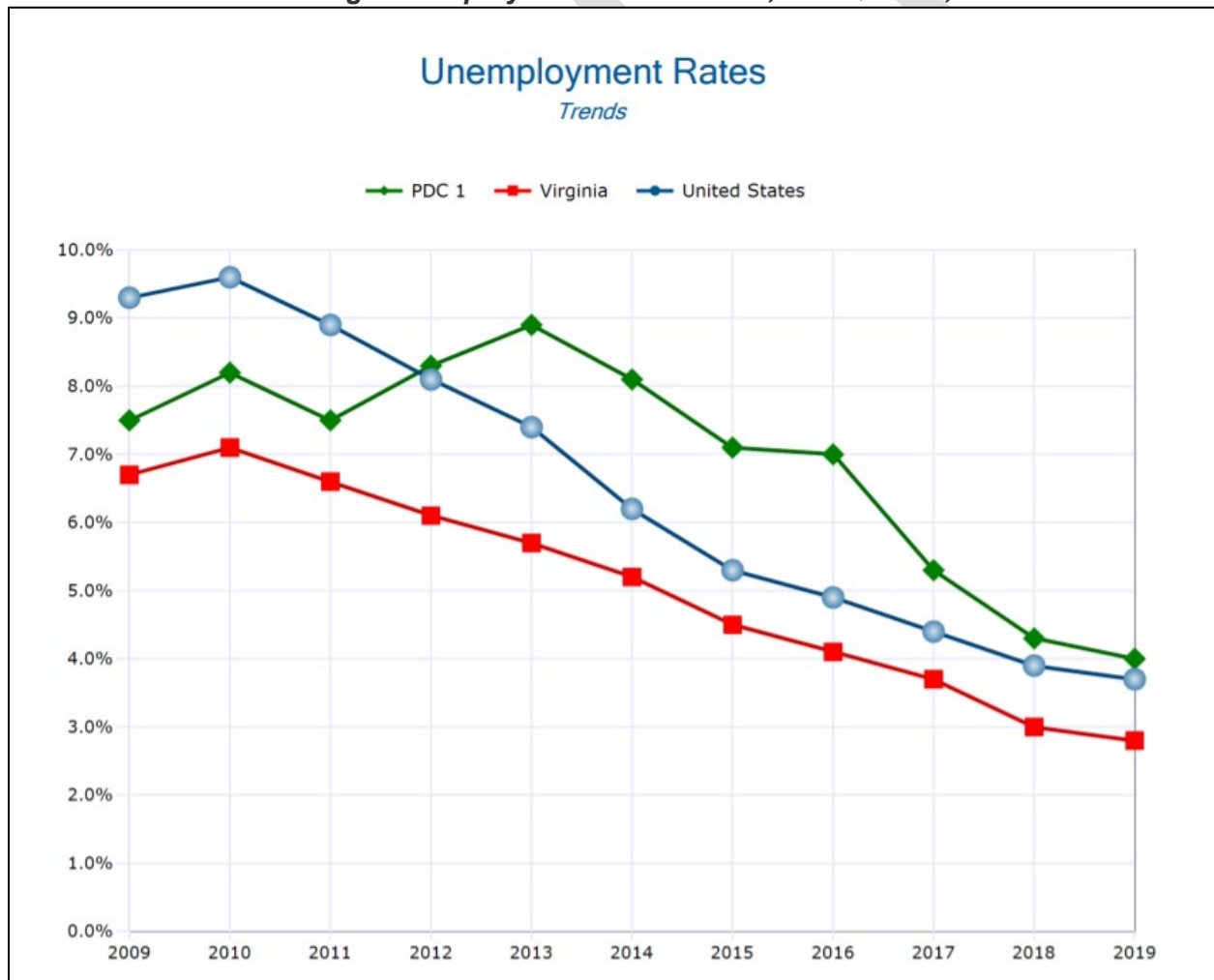

14

15



1

<b>TABLE: Unemployment Rates (2009-2019)</b>			
<b>Source: Virginia Employment Commission, 2nd Quarter, 2020</b>			
<b>Year</b>	<b>LENOWISCO</b>	<b>Virginia</b>	<b>United States</b>
2009	7.5%	6.7%	9.3%
2010	8.2%	7.1%	9.6%
2011	7.5%	6.6%	8.9%
2012	8.3%	6.1%	8.1%
2013	8.9%	5.7%	7.4%
2014	8.1%	5.2%	6.2%
2015	7.1%	4.5%	5.3%
2016	7.0%	4.1%	4.9%
2017	5.3%	3.7%	4.4%
2018	4.3%	3.0%	3.9%
2019	4.0%	2.8%	3.7%

2

<b>TABLE: Unemployment Rates (Past 12 Months)</b>			
<b>Source: Source: Virginia Employment Commission, 2nd Quarter, 2020</b>			
<b>Month</b>	<b>LENOWISCO</b>	<b>Virginia</b>	<b>United States</b>
October 2019	3.7%	2.5%	3.3%
November 2019	3.6%	2.5%	3.3%
December 2019	3.7%	2.4%	3.4%
January 2020	4.7%	3.0%	4.0%
February 2020	4.4%	2.8%	3.8%
April 2020	11.3%	10.8%	14.4%
May 2020	8.3%	8.9%	13.0%
June 2020	7.9%	8.2%	11.2%
July 2020	8.0%	8.0%	105.%
August 2020	6.0%	6.3%	8.5%
September 2020	5.9%	6.1%	7.7%

3

4



1 Local Employers and Industry

2 Government agencies, at the local, state, and federal levels, serve as the largest industry by  
 3 employment for the LENOWISCO Planning District. The top three industries by employment  
 4 include healthcare and social assistance, local government, and retail trade. The largest  
 5 employers and top industries by employment are listed in the tables below.

<b>TABLE: Largest Employers in the LENOWISCO Planning District</b> <b>Source: Virginia Employment Commission, 2nd Quarter, 2020</b>	
1	Wise County School Board
2	Food City
3	Sykes Enterprises
4	Lee County School Board
5	Scott County School Board
6	Walmart
7	Red Onion Correctional Center
8	Wallens Ridge Correction Center
9	University of Virginia, Blue Ridge Hospital
10	Norton Community Hospital
11	U.S. Department of Justice
12	Heritage Hall
13	Bristol Regional Health System
14	Mount Empire Community College
15	Mount Empire Older Citizens
16	Tempur Production
17	County of Wise
18	Frontier Health
19	Itec Healthcare Solutions
20	Telemed

6

7



1 Income and Wages

2 There is a wide range of weekly wages from the top industry types in the LENOWISCO  
 3 Planning District. Retail trade and accommodation and food services are both lower-wage  
 4 sectors, as shown in the table below, and rank in the top five industries in the District.  
 5 Government and healthcare industries tend to have higher wages.

**TABLE: Weekly Wages and Employment by Industry**  
**Source: Virginia Employment Commission, 2nd Quarter, 2020**

Rank	Industry	Number Employed	Average Weekly Wage
	Government Total	6,701	\$962
1	Healthcare and Social Assistance	3,775	\$737
2	Local Government	3,731	\$702
3	Retail Trade	3,598	\$477
4	State Government	2,210	\$832
5	Accommodation and Food Services	1,570	\$279
6	Administrative and Support and Waste Management	1,481	\$453
7	Manufacturing	1,299	\$834
8	Federal Government	760	\$1,352
9	Construction	551	\$676
10	Professional, Scientific, and Technical Services	542	\$826

6  
 7 According to 2018 American Community Survey estimates, the median household income in the  
 8 LENOWISCO Planning District is significantly lower than the national and state averages.  
 9 Jurisdictions in the District have median annual incomes ranging between approximately  
 10 \$28,000 and \$39,000, as shown in the table below. As discussed in the previous section on  
 11 poverty rates, residents with lower incomes may be less resilient to natural hazard events and  
 12 more vulnerable to significant impacts.

**TABLE: Median Household Income**  
**Source: 2018 American Community Survey 5-Year Estimates**

	United States	Virginia	City of Norton	Lee County	Scott County	Wise County
Median Household Income	\$60,293	\$71,564	\$28,071	\$32,718	\$39,144	\$38,345

13

14





### 1 1.5.5 Critical Facilities

2 The following section outlines the critical facilities located in the LENOWISCO Planning District  
 3 and each participating county. Critical facilities include major roadways, fire and rescue stations,  
 4 and schools. These facilities are categorized by the Planning District as critical facilities for the  
 5 purposes of this analysis, and do not include other important structures such as community  
 6 centers or critical infrastructure systems. These facilities will be critical in the immediate  
 7 response to a disaster or emergency event. For mitigation activities, it is important to consider  
 8 the continued operations of these facilities which serve as the hub of emergency operations,  
 9 rescue, and shelter activities. The map below shows all the critical facilities in the District.

10 **FIGURE: Critical Facilities in the LENOWISCO Planning District**

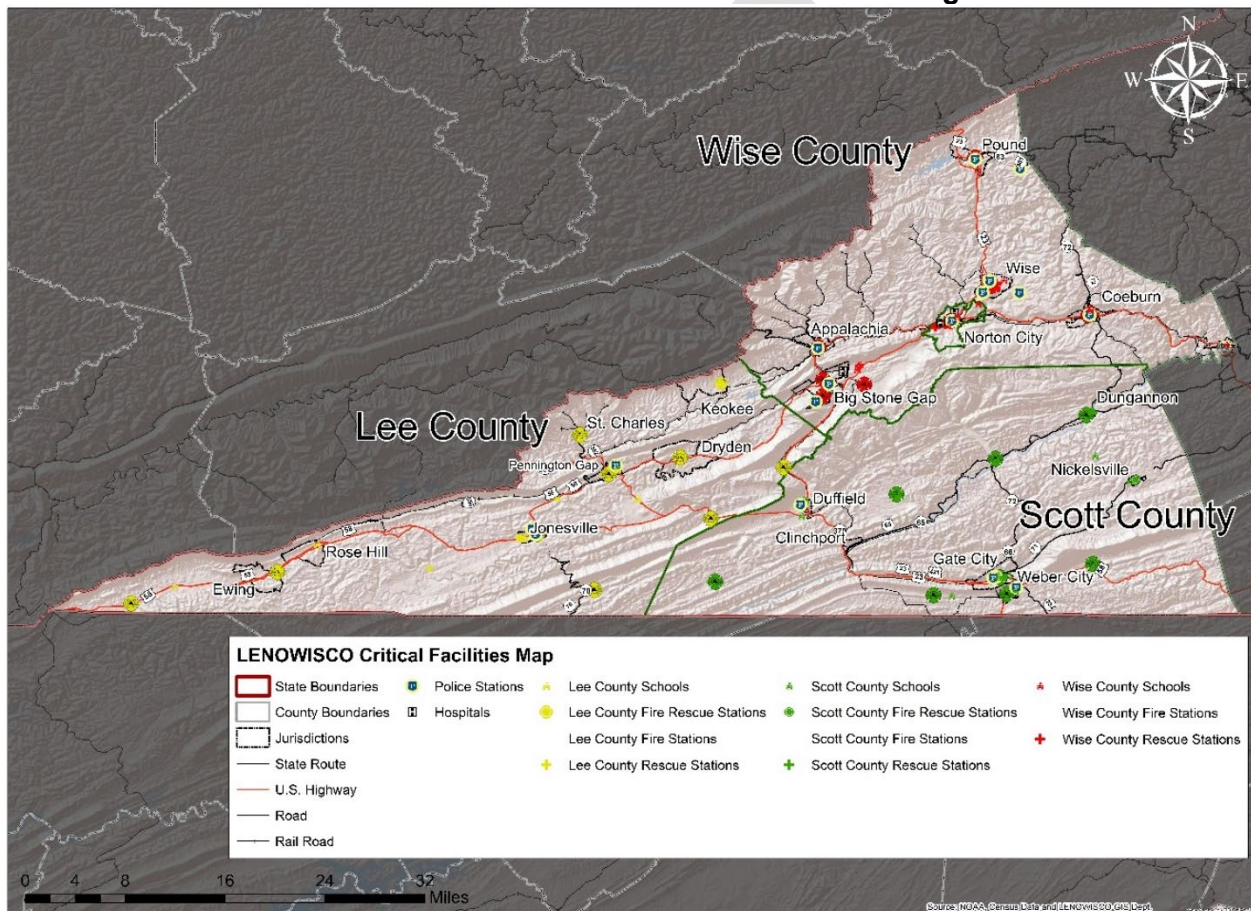

11

12



1 Lee County

2 The map below shows the critical facilities in Lee County and its local jurisdictions. The following  
 3 table provides a list of these facilities by type and location.

4 **FIGURE: Critical Facilities in Lee County**

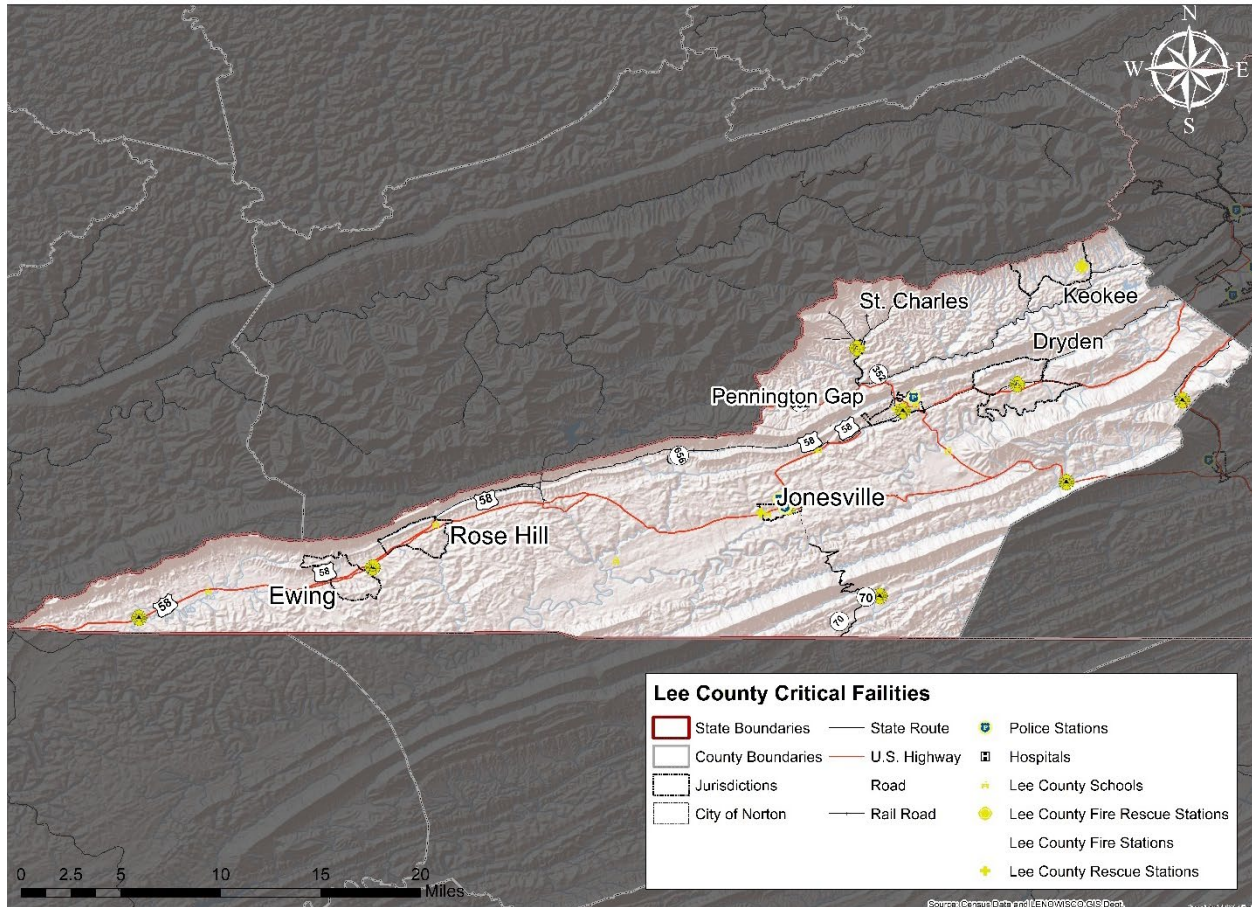

5

6





**TABLE: Critical Facilities in Lee County**

Type	Name	Address
School	St. Charles Elementary	2434 Saint Charles Rd, St. Charles, VA 24282
School	Rose Hill Elementary	150 Rose Hill Dr, Rose Hill, VA 24281
School	Jonesville Middle	160 Bulldog Cir, Jonesville, VA 24263
School	Pennington Middle	121 Bobcat Circle, Pennington Gap, VA 24277
School	Elk Knob Elementary	148 Hornet Loop Pennington Gap, VA 24277
School	Dryden Elementary	176 School House Ridge Rd, Dryden, VA 24243
School	Elydale Middle	128 Elydale Rd, Ewing, VA 24248
School	Thomas Walker High	126 Bluegrass Dr, Ewing, VA 24248
School	Lee High	200 General Ln, Jonesville, VA 24263
School	Flatwoods Elementary	205 Flatwoods School Rd, Jonesville, VA 24263
School	Lee County Career - Technical Center	181 Vo-Tech Dr, Ben Hur, VA 24218
Fire Rescue	Keokee VFD and Rescue Squad	153 Fire Hall Rd, Keokee, VA
Fire Station	Blackwater VFD	1001 A J Osborne HWY, Blackwater, VA
Fire Station	Thomas Walker VFD St #2	598 Neighborhood Ln, Ewing, VA 24248
Fire Station	Jonesville VFD	33831 Wilderness Rd., Jonesville, VA
Fire Station	Pennington Gap VFD	343 Doris Ave. Pennington Gap, VA
Fire Station	Dryden VFD	961 Dryden Loop, Dryden, VA
Fire Station	St. Charles VFD	2441 St. Charles Rd., St. Charles, VA
Fire Station	Thomas Walker VFD	170 Pioneer Rd, Ewing, VA 24248
Rescue Squad	Thomas Walker Rescue Squad	St. Rt. 879 Ewing, VA 24248
Rescue Squad	Pennington Gap Rescue Squad	316 KY Ave, Pennington Gap, VA 242777
Rescue Squad	Jonesville Rescue Squad	32254 Wilderness Rd. Jonesville, VA
Rescue Squad	St. Charles Rescue Squad	VA Rt. 352 St. Charles, VA 24282
Police Department	Pennington Gap Police Dept.	528 Industrial Dr. Pennington Gap, VA 24277
Police Department	Jonesville Police Department	842 Park St. Jonesville, VA 24263
Sheriff's Department	Lee County Sheriff's Department	33640 Main St. U 101 Jonesville, VA 24263

1  
2



1 Scott County

2 The map below shows the critical facilities in Scott County and its local jurisdictions. The  
 3 following table provides a list of these facilities by type and location.

4 **FIGURE: Critical Facilities in Scott County**

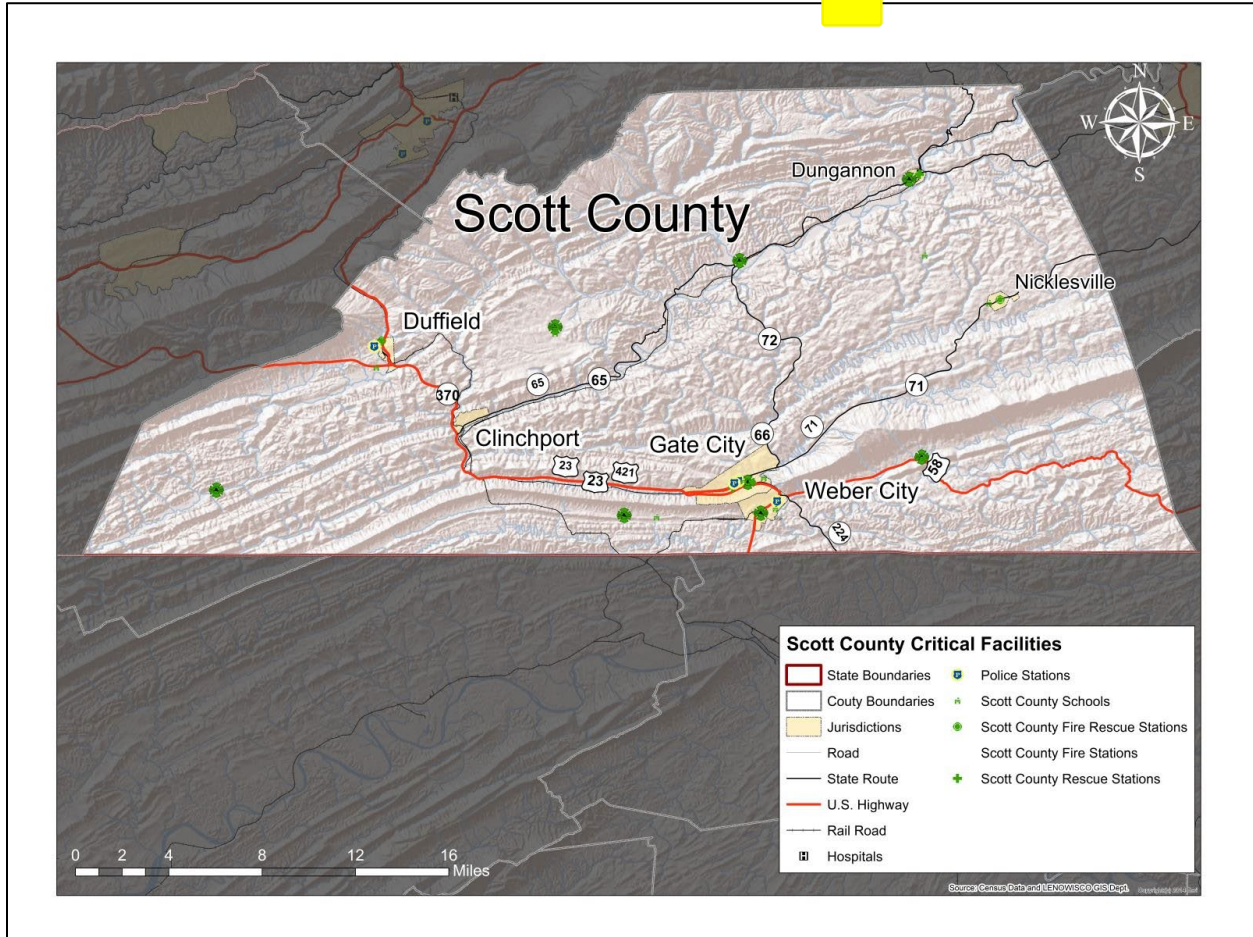

5

6



<b>TABLE: Critical Facilities in Scott County</b>		
<b>Type</b>	<b>Name</b>	<b>Address</b>
School	Scott County Career-Technical Center	387 Broadwater Ave, Gate City, VA 24251
School	Weber City Elementary	322 Jennings St, Weber City, VA 24290
School	Fort Blackmore Elementary	214 Big Stoney Creek Rd, Fort Blackmore, VA 24250
School	Dungannon Intermediate	113 Fifth Ave, Dungannon, VA 24245
School	Duffield-Pattonsville Primary School	663 Duffield-Pattonsville High, Duffield, VA 24244
School	Rye Cove Intermediate	158 Memorial School Ln, Duffield, VA 24244
School	Rye Cove High	164 Eagles Nest Ln, Duffield, VA 24244
School	Yuma Elementary	130 Grover Cleveland Ln, Gate City, VA 24251
School	Shoemaker Elementary	218 Shoemaker Dr, Gate City, VA 24251
School	Gate City Middle	170 Harry Fry Dr, Gate City, VA 24251
School	Gate City High	178 Harry Fry Dr, Gate City, VA 24251
School	Hilton Elementary	303 Academy Rd, Hiltons, VA 24258
School	Nickelsville Elementary	11415 Nickelsville Hwy, Nickelsville, VA 24271
School	Twin Springs High	273 Titan Ln, Nickelsville, VA 24271
Fire Rescue	Duffield VFD & Rescue St #1	1326 Industrial Park Rd. Duffield, VA 24244
Fire Rescue	Nickelsville VFD & Rescue Squad	11826 Nickelsville Hwy
Fire Station	Weber City VFD St #1	149 Roland St. Weber City, VA 24290
Fire Station	Duffield VFD Subst #3	110 Eagles Nest Rd Duffield, VA 24244
Fire Station	Ft. Blackmore VFD	11181 Veterans Memorial Hwy Blackmore, VA 2
Fire Station	Weber City VFD Subst. #2	5032 Yuma Rd. Weber City, VA 24290
Fire Station	Duffield VFD Subst #2	9473 Fairview Rd. Duffield, VA 24244
Fire Station	Hilton VFD	St. RT. 709 Hilton, VA 24258
Fire Station	Gate City VFD	140 Bishop St. Gate City, VA 24251
Fire Station	Dungannon VFD	18759 Veterans Memorial Hwy
Rescue Squad	Gate City Rescue Squad	100 Park St. Gate City, VA 24251
Rescue Squad	Dungannon Rescue Squad	522 4th Ave. Dungannon, VA 24245
Police Department	Gate City Police Dept.	176 E. Jackson St. Gate City, VA
Police Department	Weber City Police Dept.	2758 US 23 N. Weber City, VA
Sheriff's Department	Scott Co. Sheriff's Dept.	267 Willow St. Gate City, VA
Jail	Southwest VA Reg'l. Jail	1037 Boone Trail Rd. Duffield, VA

1

2





1 Wise County

2 The map below shows the critical facilities in Wise County and its local jurisdictions. The  
 3 following table provides a list of these facilities by type and location.

4 **FIGURE: Critical Facilities in Wise County**

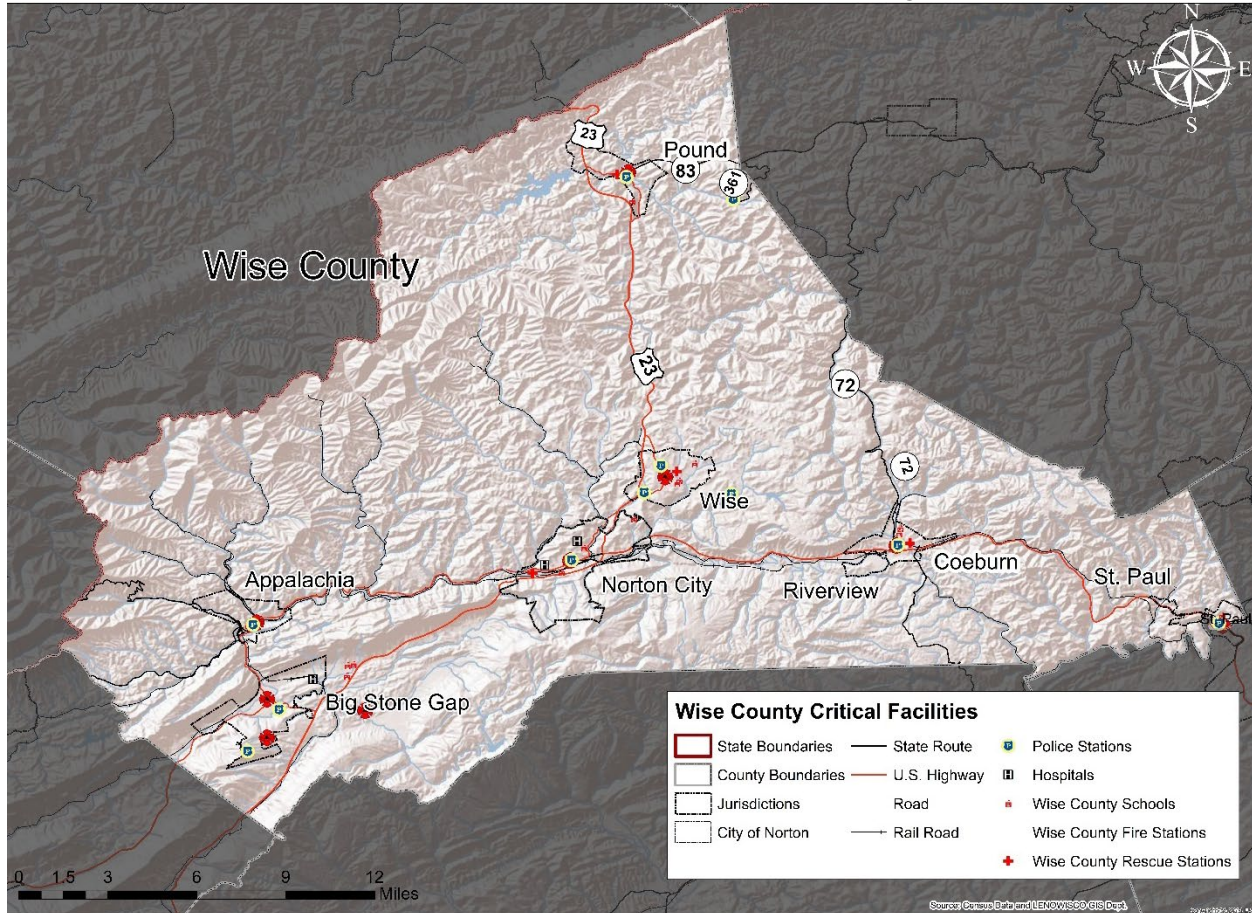

5  
 6



<b>TABLE: Critical Facilities in Wise County</b>		
<b>Type</b>	<b>Name</b>	<b>Address</b>
School	Union High	2 Champions Ave, Big Stone Gap, VA 24219
School	Coeburn Primary	332 Schoolhouse Hill Dr NE, Coeburn, VA 24230
School	St. Paul Elem.	3200 Deacon Dr, Saint Paul, VA 24283
School	Wise Co. Career-Technical Center	621 Lake St NE, Wise, VA 24293
School	L.F. Addington Middle	324 School St, Wise, VA 24293
School	Wise Primary	323 Railroad Ave SE, Wise, VA 24293
School	James Woodrow Adams Combined	10824 Orby Cantrell Hwy, Pound, VA 24279
School	Union Primary	2945 2nd Ave E, Big Stone Gap, VA 24219
School	Union Middle	30 Champions Ave, Big Stone Gap, VA 24219
School	Coeburn Middle	518 Centre Ave NE, Coeburn, VA 24230
School	J.I. Burton High	109 11Th St, Norton, VA 24273
School	Norton Elementary	205 Park Avenue Northeast, Norton, Virginia, 24273
School	Central High	5000 Warrior Dr, Norton, VA 24273
Fire Station	Pound VFD	8422 N River Rd. Pound, VA 24279
Fire Station	Big Stone Gap VFD	363 Shawnee Ave. E. Big Stone Gap, VA 24219
Fire Station	Wise VFD	307 Norton Rd. Wise, VA 24293
Fire Station	Norton VFD	100 6th St NW Norton, VA 24273
Fire Station	Appalachia VFD	102 Powell St. Appalachia, VA 24216
Fire Station	St. Paul VFD	16636 Russell St., St. Paul, VA 24283
Fire Station	Powell Valley VFD	1946 Tate Spgs. Rd. Big Stone Gap, VA 24219
Fire Station	Coeburn VFD	114 Front St. E. Coeburn, VA 24230
Fire Station	Big Stone Gap VFD Station 2	1364 Dogwood Dr. Big Stone Gap, VA 24219
Rescue Squad	Appalachia Rescue Squad	540 W. Main St. Appalachia, VA 24216
Rescue Squad	Big Stone Gap Rescue Squad	361 Shawnee Ave. E. Big Stone Gap, VA 24219
Rescue Squad	Norton Rescue Squad	1710 Main Ave. SW Norton, VA 24273
Rescue Squad	Pound Rescue Squad	8316 Main St. Pound, VA 24279
Rescue Squad	Wise Rescue Squad	302 Railroad Ave. Wise, VA 24293
Rescue Squad	Coeburn Rescue Squad	522 Second St. N. Coeburn, VA 24230
Police Department	Appalachia Police Dept.	508 Main St. Appalachia, VA 24216
Police Department	St. Paul Police Dept.	16531 Russell St., St. Paul, VA 24283
Police Department	Wise Police Dept.	501 W. Main St. Wise, VA 24293
Police Department	Norton City Police Dept.	618 Virginia Ave. NW Norton, VA 24273





Police Department	Coeburn Police Dept.	114 Front St. E. Coeburn, VA 24230
Police Department	Big Stone Gap Police Dept.	505 E. 5th St. Big Stone Gap, VA 24219
Police Department	Pound Police Dept.	8422 N. River Rd Pound, VA 24279
Police Department	VA State Police Headquarters	1207 Norton, Rd. Wise, VA 24293
Sheriff's Department	Wise Co. Sheriff's Dept	5605 Patriot Dr. Wise, VA 24293
Police Department	Wallens Ridge State Prison	1052 Dogwood Dr. Big Stone Gap, VA 24219
Prison	Red Onion State Prison	1080 Jack Rose Hwy Pound, VA 24279
Hospital	Lonesome Pine Hospital	1990 Holton Ave. Big Stone Gap, VA 24219
Hospital	Norton Community Hospital,	100 15th St. NW Norton, VA 24273
Hospital	Mountain View Regional Hospital	310 3rd St. NE Norton, VA 24273

1  
2

DRAFT



1 **1.5.6 Capability Assessment**

- 2 This section provides a capability assessment for the LENOWISCO Planning District. This is a summary of capability across the  
 3 District. An assessment is available by jurisdiction in the plan annexes for Lee County (2.4), Scott County (3.4), and Wise County  
 4 (4.4), City of Norton (5.4), as well as for each participating locality. This assessment includes the following capabilities:
- 5 • Legal and Regulatory Capability
  - 6 • Fiscal Capability
  - 7 • Administrative and Technical Capability (of the LENOWISCO Planning District staff only)
- 8 The LENOWISCO Planning District provides its member jurisdictions with:
- 9 • A forum for state and local governments on various issues including local infrastructure planning and development. Emphasis  
 10 has been placed on Community Development, Economic Development, Transportation, and Public Utility Infrastructure.
  - 11 • Grant writing and grant management services utilizing several community development programs. Emphasis is also being  
 12 placed on both traditional economic development and new sector economic development.
  - 13 • Geographic Information Services (GIS) to assist the member localities and the local community.

**TABLE: Legal and Regulatory Capability**

	Local Authority	County Run	Other Jurisdictional Authority	Comments
<b>Codes, Ordinances &amp; Requirements</b>				
Building Code	Yes	Yes	No	Both jurisdictions and counties in the District enforce building ordinances.
Zonings	Yes	Yes	No	Both jurisdictions and counties in the District enforce zoning ordinances.
Subdivisions	Yes	Yes	No	Most jurisdictions in the District have a subdivision ordinance.
Stormwater Management	Yes	Yes	No	Most jurisdictions in the District have stormwater management included in their zoning ordinance.
Post Disaster Recovery	No	Some	No	Wise County is the only jurisdiction to recently complete a post-disaster recovery process.



Growth Management	Some	Yes	Yes	LENOWISCO Planning District develops regional planning documents that influence growth management and economic development. LENOWISCO is a designated Economic Development District. Some counties and jurisdictions support Economic Development Committees.
Public Health and Safety	No	Yes	Yes	The LENOWISCO Health District is the regional health authority. It is supported by the local Lee County, Scott County, and Wise County Health Departments.
<b>Planning Documents</b>				
General or Comprehensive Plan	Some	Yes	No	LENOWISCO Planning District can assist jurisdictions in creating comprehensive plans. Each county has an updated comprehensive plan, as well as some jurisdictions.
Environmental Protection	No	No	No	LENOWISCO PDC has a transportation planner on staff. In 2011, the District developed the LENOWISCO Long-Range Transportation Plan for rural transportation routes. Jurisdictions rely on VDOT for most major transportation planning efforts.
Transportation Plan	No	No	Yes	
<b>Response/Recovery Planning</b>				
Comprehensive Emergency Management Plan	No	Yes	No	Counties reported having either a Comprehensive Emergency Management Plan or Emergency Operations Plan that is used by the local jurisdictions.
Community Wildfire Protection Plan	No	No	No	
Post-Disaster Recovery Plan	No	Some	No	Wise County is the only jurisdiction to recently complete a post-disaster recovery process.
Continuity of Operations Plan	Some	Some	No	Some communities noted they had a Continuity of Operations Plan, or at least a limited version specific to a single hazard.



1

**TABLE: Administrative and Technical Capability**

<b>Staff/Personnel Resources</b>	<b>Available?</b>	<b>Department/Agency/Position</b>
Planners or engineers with knowledge of land development and land management practices	No	
Engineers or professionals trained in building or infrastructure construction practices	No	
Planners or engineers with an understanding of natural hazards	No	
Surveyors	No	
Personnel skilled or trained in GIS applications	Yes	Director of GIS; available for contract to jurisdictions
Emergency manager	No	
Grant writers	Yes	Various Planning Department staff

2

3



## 1 1.5.7 Land Use and Future Development

2 Each jurisdiction within the LENOWISCO Planning District is responsible for land use planning  
3 and zoning. Additionally, LENOWISCO Planning District contracts with municipalities to provide  
4 capacity for plan and ordinance updates, as well as regional planning efforts. Relevant policies  
5 and regulatory documents for land use and development include:

- 6 • [City of Norton Comprehensive Plan, 2003](#)
- 7 • [City of Norton City Code, Zoning Ordinance Chapter](#)
- 8 • [Lee County Comprehensive Plan, 2020](#)
- 9 • [Lee County Zoning Ordinance](#)
- 10 • [Scott County Comprehensive Plan, 2017](#)
- 11 • [Scott County Zoning Ordinance](#)
- 12 • [Wise County Comprehensive Plan, 2020](#)
- 13 • [Wise County Zoning Ordinance](#)

14 The jurisdictions within the LENOWISCO Planning District have collectively experienced a  
15 declining population over several decades, which is projected to continue through 2040. With a  
16 shrinking and aging population base, the communities are preparing for future land use and  
17 development patterns to meet changing needs. A historic reliance on the coal mining industry  
18 has also contributed to a declining tax revenue base, restricting the resources available for  
19 adequate public services and facilities. These conditions point to the need for increased public  
20 services, economic development, and affordable and attainable housing solutions, which are all  
21 rooted in development and land-use patterns.

22 Each of the jurisdictions emphasizes the importance of efficient infrastructure provision and the  
23 maintenance and resilience of sewer and water infrastructure. Developable land in the District is  
24 concentrated along transportation corridors and in areas with existing access to critical  
25 infrastructure. Several of the communities' future land use maps explicitly note that primary  
26 development areas are those served by existing infrastructure to streamline service provision.  
27 Future development in the region is limited due to the significant amount of land on steep slopes  
28 (those over 20% grade), poor soil conditions, existing forest lands (both public and private),  
29 mining and mineral operations and land ownership, and an excess of flood-prone land. The  
30 jurisdictions each treat development in the flood plain differently, with some explicitly prohibiting  
31 development in the 100-year floodplain, with others only limiting development types.

32 Other key land use and development trends are detailed by jurisdiction in the following sections.

33





## 1 Lee County Land Use and Future Development

2 The population of Lee County has remained somewhat stable over the past several decades,  
3 with population increases at the 1980 and 2010 Census standing out from an otherwise steady  
4 period of decline. Population projections indicate a minimal but continued decline through 2040.  
5 Lee County updated its Comprehensive Plan in October 2020, serving as a policy guide to  
6 development and land use decision-making within the county given trends in the local  
7 population, economy, and public service provision.

8 As discussed in the topography, geography, and geology section of this plan (1.5.1), Lee  
9 County and its neighbors face many development constraints, including steep slopes, poor soil  
10 conditions, flood-prone areas, mineral land under development, land subject to subsidence from  
11 underground mining, and the presence of National Forest and other public lands. Of 278,910  
12 acres in Lee County, about 82% have slopes in excess of 20% and another 6.4% between 10-  
13 20%. When combined with flood-prone land, poor access, or limited public facilities, Lee County  
14 faces a "critical lack of land suitable for future urban-type development" ([Lee County](#)  
15 [Comprehensive Plan, p. 8](#)).

16 Due to these restrictive factors, much of the historical development in Lee County is  
17 concentrated along main transportation corridors (Highways 23 and 58) and within the  
18 floodplain, as the roadways tend to follow the paths of rivers and creeks. Land along plateaus or  
19 ridge tops may be more suitable for development but does not have adequate transportation or  
20 utility access. These patterns, combined with economic decline, have led to the "physical  
21 deterioration of many of the County's urban and built-up areas, the continuation of only  
22 marginally functional land uses, and the unavailability of certain public services" ([Lee County](#)  
23 [Comprehensive Plan, p. 33](#)).

24 The 2020 Comprehensive Plan outlines several considerations for future land use and  
25 development, including recommending policies to improve the quality of timber in the county's  
26 forest lands, continuing mine reclamation activities, maintaining fertile lands for agricultural  
27 uses, restricting development in flood-prone areas, leveraging existing public sewage and water  
28 service facilities, and discouraging incompatible uses, among others. The plan includes two  
29 objectives regarding land use policies:

- 30 1. Maximize the current land use patterns that have been established while looking at  
31 possible land use changes that could better the development of the County
- 32 ○ Encourage development along transportation corridors
- 33 2. Minimize disturbance to existing land use when new land use takes place
- 34 ○ Practice responsible regrowth and planting
- 35 ○ Follow a sediment control plan
- 36 ○ Follow floodplain management practices

37



1 Scott County Land Use and Future Development

2 Similar to its neighboring counties, the population of Scott County has decreased since 1950,  
3 and is projected to continue its decline over the next twenty years. There have been some small  
4 population booms associated with the coal industry. The population that remains is steadily  
5 aging, driving the need for public services and facilities, as well as different housing types.  
6 Roughly 18% of residents live in the 8.5% of the county lands that make up six incorporated  
7 towns.

8 Scott County stretches 538 square miles (344,320 acres) and is blanketed with a network of  
9 rivers and streams. These water resources have determined historical development patterns  
10 and economic drivers, including agriculture. Most of the residential water supply relies on  
11 groundwater, including underground springs and wells, as well as some creeks. Forest land  
12 currently makes up about 62% of Scott County, but that amount ranged between 54% and 74%  
13 in just the second half of the 20th century. Poor management practices have degraded the  
14 quality of forest lands in many parts of the county.

15 According to the [2017 Scott County Comprehensive Plan](#), most developable land in the county  
16 has been developed with no major changes expected. Future development will be concentrated  
17 on transportation corridors and through the expansion of existing developable areas. Past and  
18 future development in the county has been restricted due to flood-prone areas, steep slopes  
19 (88% of acres have a slope of 20% or greater), poor soil conditions, lack of utilities in certain  
20 areas, and incompatible land use mixes. The Scott County floodplain development regulations  
21 do not currently prohibit development in the floodplain but attempt to strongly discourage certain  
22 types.

23 The 2017 Comprehensive Plan provides policy guidance for future land use and transportation  
24 through the map below. The map designates areas for future development using the following  
25 criteria:

- 26 • Areas subject to flooding should not be developed
- 27 • Development should be directed toward areas that have access to public sewer or are  
28 suitable for septic system drain fields
- 29 • Areas with public water supply service should be developed prior to areas without such  
30 service
- 31 • Areas with adequate road access should be developed prior to areas without such  
32 access

33

34



1  
2

**FIGURE: Scott County Future Land Use and Transportation Map**  
**Source: [2017 Scott County Comprehensive Plan](#) (Appendix B, PDF Page 57)**

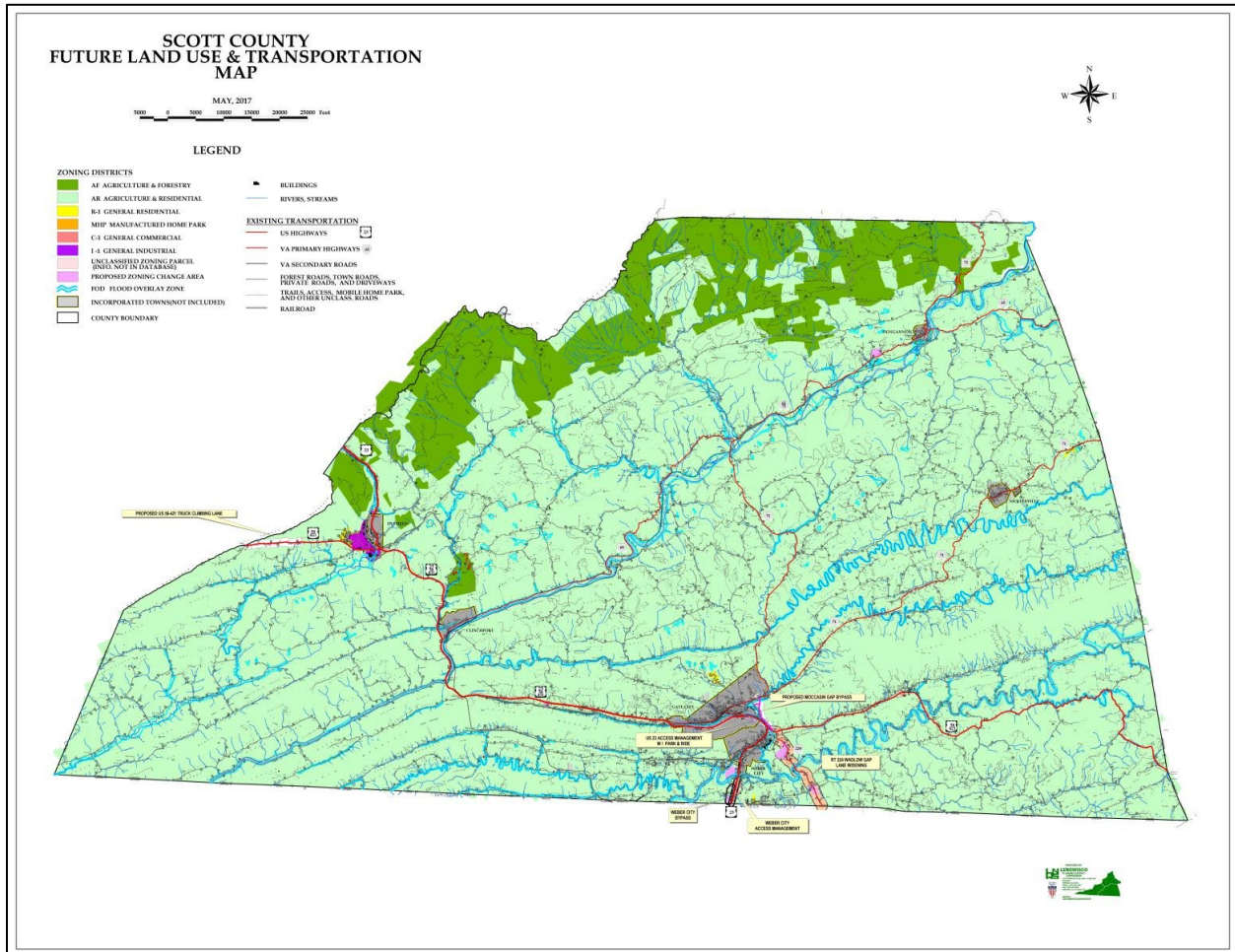

3  
4



## 1 Wise County Land Use and Future Development

2 As discussed in the demographics section (1.5.3), projections show Wise County will lose  
3 population over the next twenty years. The population will also get older, shifting the demand for  
4 public services and facilities, such as different housing types, medical services, and  
5 transportation options. Wise County also faces declining wages and a growing unemployment  
6 rate, economic factors often associated with the rapidly declining coal industry. These  
7 conditions point to the need for increased public services, economic development, and  
8 affordable and attainable housing solutions, which are all rooted in development and land use  
9 patterns ([2020 Wise County Comprehensive Plan](#)).

10 Wise County makes up 249,312 acres, of which 67% (or 167,444 acres) is forestland. The vast  
11 majority (86.5%) of forest lands in the county are privately owned, while about 11% are part of  
12 the National Forest System and 2.6% are state forest. Wise County also has an extensive  
13 reservoir system, providing municipal drinking water to its residents through six reservoirs. This  
14 watershed is vulnerable to land use and development patterns, as well as the ongoing health of  
15 the forest land across the county. Land use and development are also constrained by steep  
16 slopes - over 92% of the county's land area has slopes greater than 20%, poor soil conditions,  
17 and flood-prone areas.

18 Development is also restricted by the vast network of active and abandoned underground mines  
19 across Wise County, as illustrated in the map below. Over 50% of the county's surface property  
20 is not available for development because of the sub-surface mining and mineral rights owned by  
21 private coal and resource companies, as well as the U.S. Forest Service. This patchwork of land  
22 ownership limits development and creates a risk of land subsidence.

23 **FIGURE: Active and Underground Mines in Wise County**  
24 **Source: [2020 Wise County Comprehensive Plan \(Page 140\)](#)**

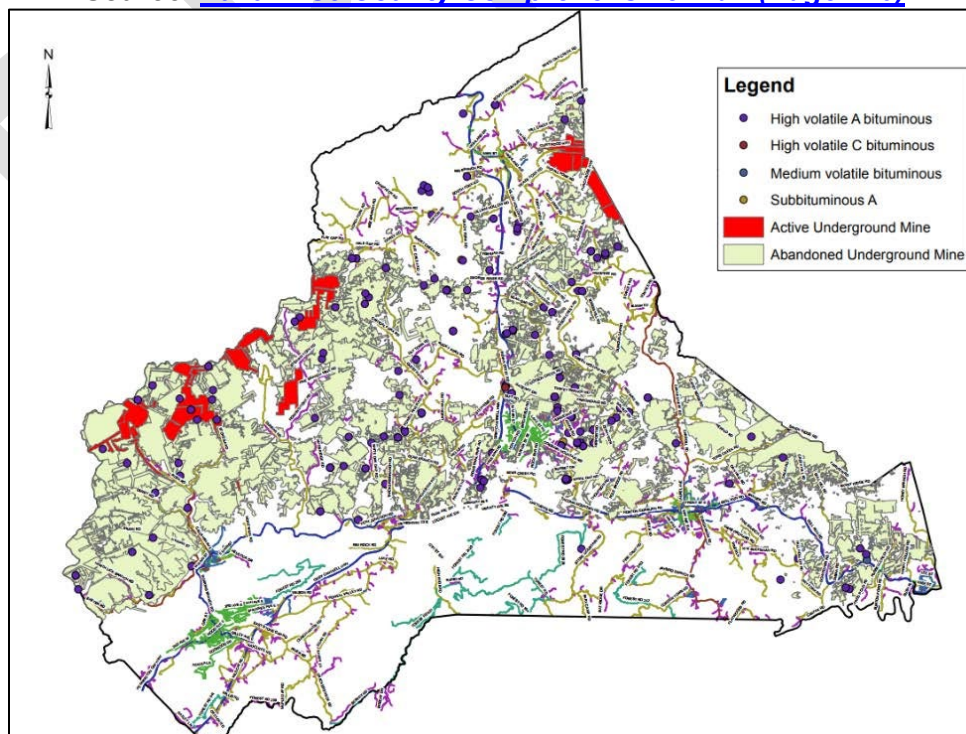





1 Wise County has been historically reliant on tax revenues from a thriving mining industry. As  
2 noted in the [2020 Wise County Comprehensive Plan](#), "the County didn't plan on a time when  
3 coal would not be part of our economy, because times were good, and money was flowing." The  
4 rapid drop in coal revenues was significant - from \$13 million in 2011 to just \$3 million in 2015.  
5 This reduction in tax revenue significantly limited the resources available for essential  
6 community services and critical infrastructure. The new comprehensive plan outlines  
7 "development tiers" to create a more functional land use plan and more reliable development  
8 patterns. This system provides a framework for growth management across the county,  
9 recognizing the need to provide efficient public services and protect rural and agricultural lands,  
10 as well as environmental resources and open spaces. The resulting Strong Community  
11 Development Plan seeks to "provide the County with an effective strategy to establish planning  
12 policies and manage spending to optimize investments in services and infrastructure, protects  
13 the natural environment, reduces potential loss of life and property from natural hazards,  
14 provides a clear direction to achieve an efficient development pattern and support and  
15 coordinate with its communities."

16 The Development Plan includes three tiers: primary development areas, secondary  
17 development areas, and rural/natural resources areas. These areas are illustrated in the map  
18 below.

19  
20

**FIGURE: Development Areas in Wise County**  
**Source: [2020 Wise County Comprehensive Plan \(Page 179\)](#)**

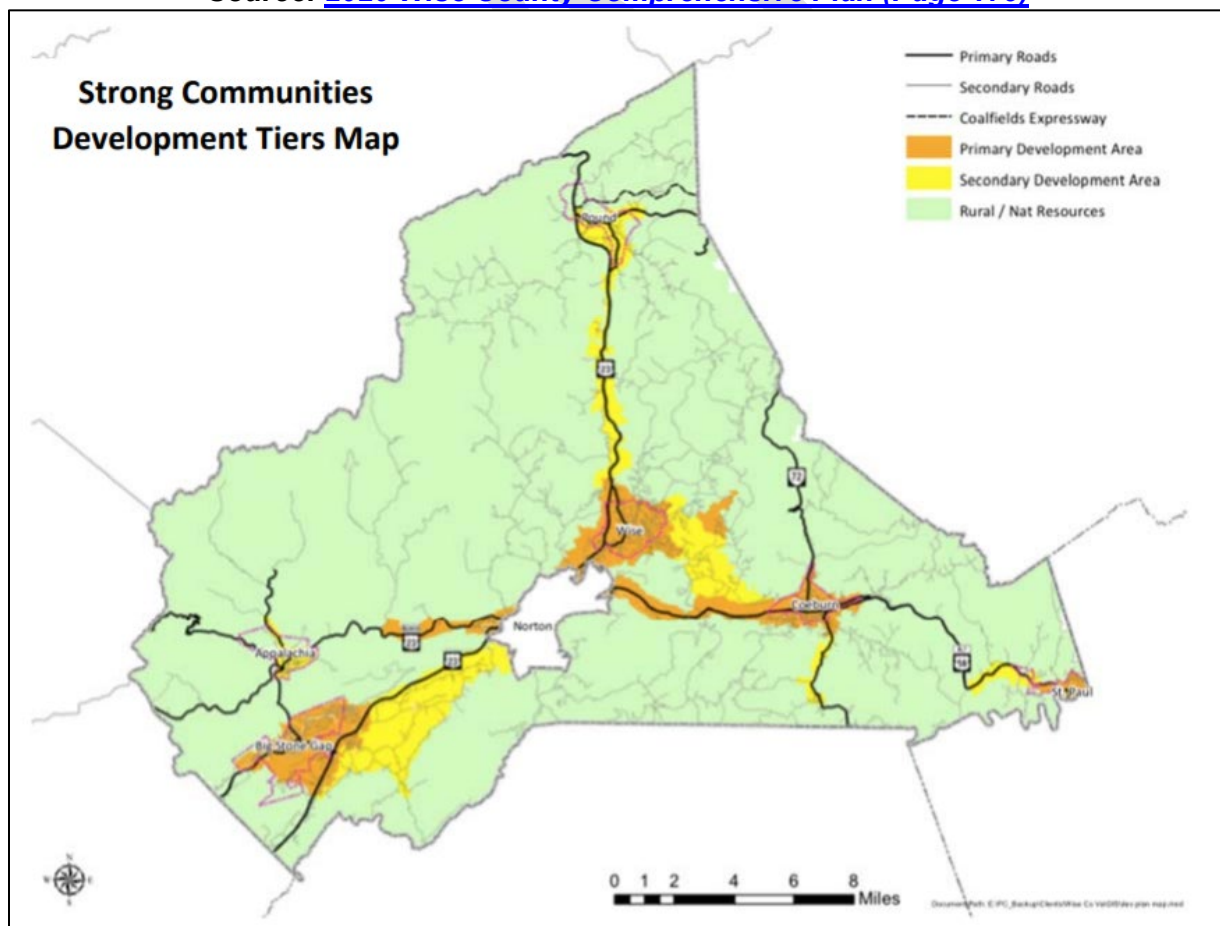

21





1 Even with a tradition of rural land use and development patterns, Wise County prioritizes future  
2 development that is more compact, served by adequate facilities, introduces fewer costs, and  
3 reduces impacts to agricultural and natural resource lands. This is a departure from large lot,  
4 rural development. This policy directive, as outlined in the comprehensive plan, will guide future  
5 land use patterns and infrastructure planning, as illustrated in the map below.

6 **FIGURE: Wise County Future Land Use Map**  
7 **Source: 2020 Wise County Comprehensive Plan (Page 181)**

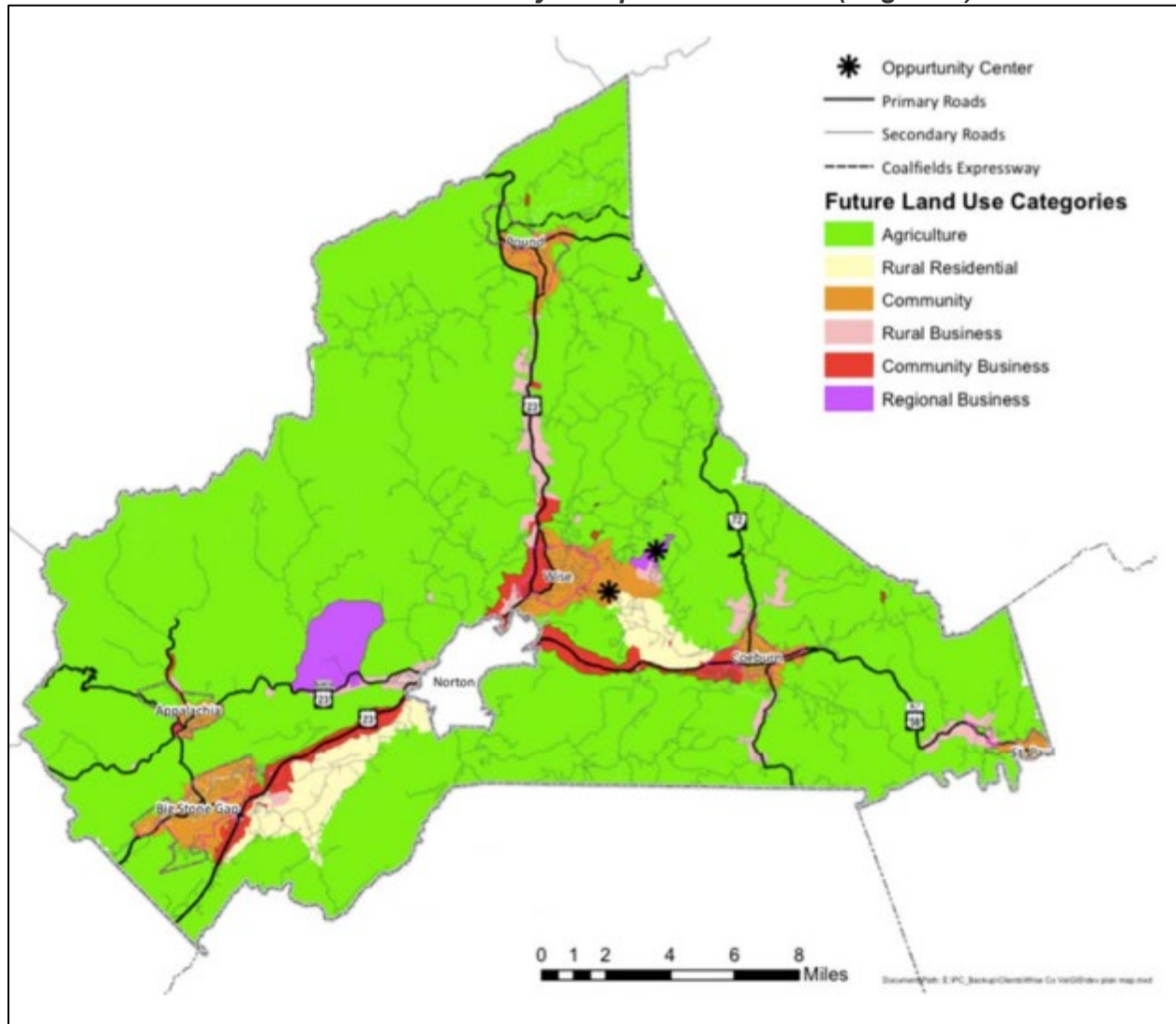

8  
9



1 City of Norton Land Use and Future Development

2 The City of Norton last updated its [Comprehensive Plan](#) in 2003, covering a planning period  
3 through 2020. An update to the Norton Comprehensive Plan was underway during the  
4 development of the Hazard Mitigation Plan. The plan serves as a policy guide for long-term  
5 land-use decision-making and future development strategies within the City. As outlined in the  
6 Demographics section (1.5.3), the City of Norton is projected to lose population over the next  
7 twenty years. Norton's population has steadily declined since 1980, similar to its neighboring  
8 communities and Wise County as a whole. As with Wise County, Norton has historically been  
9 reliant on coal industry employment and tax revenues to support the local economy. Even in  
10 2003 when the comprehensive plan was developed, the decline of the coal mining industry was  
11 apparent.

12 The comprehensive plan outlines several strategies related to future development in adopting  
13 the future land use map below. These strategies include designating sufficient land for future  
14 housing to accommodate growth, promoting infill housing, redeveloping key downtown  
15 commercial areas, and evaluating effective strategies for public service provision. The future  
16 land use map also indicates areas reserved for conservation and land in the 100-year flood  
17 plain.

18 **FIGURE: City of Norton Future Land Use Map, 2003**  
19 **Source: [Norton 2020 Comprehensive Plan](#) (PDF Page 42)**

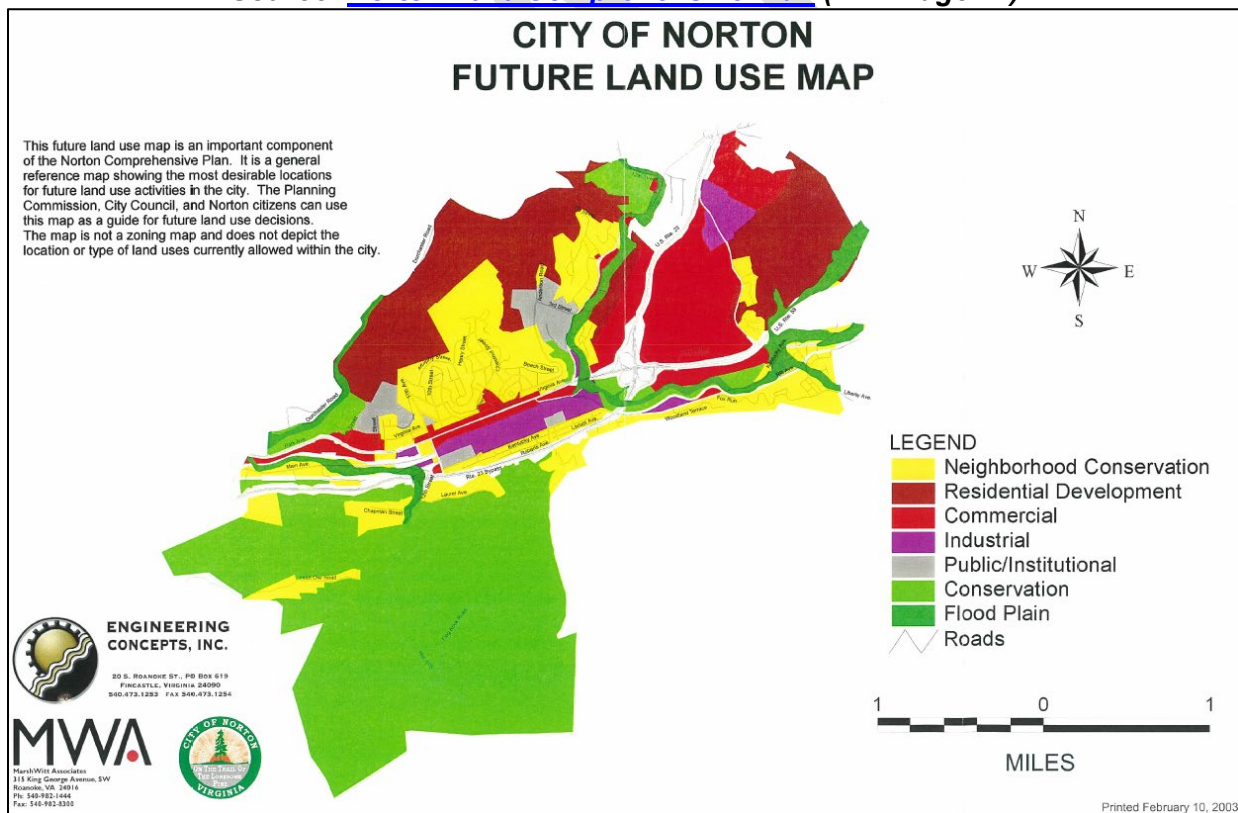

20  
21 The City of Norton enforces the Virginia Uniform Statewide Building Code and the Norton City  
22 Code. The City Code includes a chapter on Zoning Ordinances, [available here](#). The most recent  
23 zoning map for the City of Norton is [available here](#).



## 1 Section 1.6 Risk Assessment Overview

2 The following section provides a detailed risk assessment for the LENOWISCO Planning  
3 District. The assessment includes profiles of eleven natural hazards facing the District, the  
4 methodology used to rank each hazard by risk and vulnerability, and the results of the  
5 assessment.

### 6 1.6.1 Communicable Disease

7 A communicable disease spreads between people through contact with blood and bodily fluids,  
8 an airborne virus, or insect bites. A widespread communicable disease can cause a public  
9 health emergency as either a more localized epidemic or a global pandemic. A pandemic is a  
10 communicable disease that has spread around the world, causing illness on nearly every  
11 continent. Pandemics typically contribute to widespread economic and social impacts through  
12 long response and recovery periods. Historically, there is a pandemic every 30 years, although  
13 there have been two pandemics as declared by the World Health Organization in the 21st  
14 century, including H1N1 in June 2009 and COVID-19 in March 2020. Pandemic influenza  
15 represents one of the greatest threats within this hazard category and historically has had  
16 significant impacts globally ([CDC](#)).

17 Pandemics typically occur in waves lasting anywhere from six to eight weeks. As immunity is  
18 developed within a population, the virus will recede for a period of 8-12 weeks. The virus will  
19 then reemerge slightly mutated for another wave lasting six to eight weeks. The process then  
20 repeats during a pandemic two to three times.

21 Symptoms of pandemic influenza vary depending on the virulence of the strain but mirror typical  
22 seasonal symptoms including, fever, coughing, sore throat, congestion headaches, soreness in  
23 the muscles and joints, chills, and fatigue. During a pandemic, these symptoms can be severe  
24 resulting in hospitalizations and death. The infection rate and mortality rate, two indicators of  
25 severity, can vary between influenza strains. The mortality rate of the 1918 influenza was about  
26 3%, with an infection rate of 30-40%. The mortality rate and the emergence of severe  
27 complications are higher for certain populations, including infants, the elderly, and people with  
28 pre-existing health conditions or compromised immune systems. That said, healthy young  
29 adults can also be affected by certain strains, including COVID-19.

30 The most effective strategy for combating pandemic influenza is vaccination. However, since a  
31 pandemic is caused by a novel strain, it is likely vaccine will not be available for the first wave  
32 and sometimes not until the middle of the second wave. Alternate strategies for mitigation  
33 include the use of antiviral medication, antibiotics for bacterial pneumonia often associated with  
34 influenza, social distancing, and public health hygienic practices.

#### 35 [COVID-19](#)

36 Coronavirus disease 2019, commonly called COVID-19, is an infectious disease caused  
37 by severe acute respiratory syndrome coronavirus 2 (SARS-CoV-2). The disease was first  
38 identified in December 2019 in Wuhan, Hubei, China, and has since been traced back to an  
39 open animal market ([CDC](#)). COVID-19 is an ongoing pandemic at the time of this plan update.  
40 In 2020, there were nearly 80 million cases reported, with more than 1.5 million deaths globally.  
41 In the United States alone, there were nearly 20 million cases and 344,000 deaths. The United



1 States has the most cases of any country in the world, followed by India and Brazil ([World](#)  
 2 [Health Organization](#)).

3 Common symptoms include fever, cough, fatigue, shortness of breath, and loss of  
 4 smell and taste. While the majority of cases result in mild symptoms, some progress to acute  
 5 respiratory distress syndrome (ARDS) possibly precipitated by cytokine storm, multi-organ  
 6 failure, septic shock, and blood clots. The time from exposure to onset of symptoms is typically  
 7 around five days but may range from two to fourteen days.

8 COVID-19 is spread through close contact, typically through respiratory droplets produced  
 9 through coughing, sneezing, talking, or breathing. Transmission occurs through droplets that  
 10 remain in the air for some amount of time. People infected with COVID-19 are most contagious  
 11 during the early stages of the disease, including before symptom onset through the first three  
 12 days after symptoms appear. Many people appear to be asymptomatic carriers of the disease,  
 13 complicating efforts to reduce transmission and track cases ([CDC](#)).

14 Public health professionals have recommended safe behaviors to reduce spread, including  
 15 wearing a mask when in close contact with people outside your household, frequent  
 16 handwashing, and quarantine after potential or confirmed exposure to someone carrying the  
 17 virus.

18 The United States has experienced an ongoing increase in COVID-19 cases, with several  
 19 waves that vary between regions of the country. In early November 2020, the United States  
 20 topped 100,000 new cases daily. By the end of 2020, Virginia had a seven-day average of 42  
 21 new daily cases per 100,000 people, resulting in nearly 4,000 new cases daily. The CDC  
 22 threshold for low incidence is less than 1.5 cases per 100,000 people. Virginia alone reported  
 23 about 350,000 cases of COVID-19 in 2020 ([CDC](#)).

24 *COVID-19 in the LENOWISCO Planning District*

25 Two federal disaster declarations (#3448 of March 13, 2020, and #4512 on June 11, 2020) were  
 26 declared for the COVID-19 pandemic, inclusive of the LENOWISCO Planning District.

27 The following table shows cases of COVID-19 in LENOWISCO as of the end of 2020. As with  
 28 many more rural communities, the jurisdictions in the LENOWISCO Planning District saw a later  
 29 onset of COVID-19 community spread, with a small wave in the summer of 2020, with a  
 30 significant increase beginning in October of 2020.

<b>TABLE: COVID-19 Case Counts in the LENOWISCO Planning District</b>		
<i>Source: Virginia Department of Health</i>		
<b>Jurisdiction</b>	<b>Confirmed Cases</b>	<b>Deaths</b>
City of Norton	179	1
Lee County	1,492	29
Scott County	1,214	34
Wise County	2023	59

31

32 The impacts of the COVID-19 crisis will continue to unfold as this HMP is being written. In  
 33 the Economy section (1.5.4), recent shifts in unemployment and other local impacts are  
 34 discussed in more detail.





1 Hazard Extent

2 Pandemic Influenza generally occurs in multiple waves (2 to 3) that last a period of six to eight  
 3 weeks each. Generally, each wave will occur approximately 12 weeks apart. Once a novel  
 4 strain of influenza can achieve human to human transmission, the pandemic is expected to  
 5 spread rapidly and across geographic barriers.

6 Although the likelihood of pandemic is a certainty, their frequency is difficult to predict. In the  
 7 20th century, there were three influenza pandemics. In the 21st century, there have already  
 8 been two - the ongoing COVID-19 pandemic, and the 2009 H1N1 pandemic. Pandemic  
 9 influenza is characterized based on its ability to spread, not its virulence. Pandemics in the past  
 10 have ranged from severe to mild.

11 History/Previous Occurrences

12 The Commonwealth of Virginia has a long and documented history of illness and disease,  
 13 dating to the pre-colonial era. Later settlers experienced a variety of infectious and  
 14 communicable diseases, often caused by famine, vitamin deficiencies, and exposure to new  
 15 pathogens. In addition to the global COVID-19 pandemic in 2020 described in detail above,  
 16 Virginia experienced three significant communicable disease outbreaks during the HMP  
 17 planning period (2015-2020), described in the table below.

<b>TABLE: Recent Disease Occurrences in Virginia, 2015-2020</b> <b>Source: 2018 Commonwealth of Virginia Hazard Mitigation Plan</b>	
2015	In 2015, three EEE-infected horses were reported in the eastern region and one West Nile Virus (WNV) infected horse was reported in the northern region. Testing of sentinel chickens revealed 21 WNV-positive chickens in the Chesapeake, Norfolk, Suffolk, and Virginia Beach area, and 19 EEE-positive chickens in the Chesapeake, Norfolk, Suffolk, and Virginia Beach area.
2016	In 2016, the Virginia Department of Health investigated a statewide outbreak of hepatitis A caused by the widespread distribution of a commercial food product that was contaminated with the hepatitis A virus (HAV). A total of 110 Virginia residents infected with HAV were linked to the outbreak, with illness onsets occurring from May to October 2016. Approximately 35% of patients were hospitalized and no deaths were reported. Adults were more commonly affected, with patients ranging in age from 14-70 years (median 36); only 20% of persons affected were 19 years or younger. The most commonly reported symptoms were nausea (90%), fatigue (89%), dark urine (84%), and anorexia (83%). The product that was contaminated was imported frozen strawberries, which were used in smoothies. Of patients who could recall the type of smoothie consumed (n=96), 100% reported drinking a smoothie containing frozen strawberries. FDA testing identified a virus in the strawberries, which had been imported from Egypt.
2016	Prior to December 2015, there were no documented cases of Zika virus disease in Virginia. As of February 2017, there were 114 confirmed cases of Zika virus disease in Virginia. Half of these cases were in the Northern Health Planning Region; 17% were in the Northwest Region, 15% were in the Central Region, 10% were in the Southwest Region, and the remaining 9% were in the Eastern Region.

18

19





1 The Virginia Department of Health (VDOH) tracks reportable diseases throughout the  
 2 Commonwealth, including the most common communicable disease by county. As illustrated  
 3 below, all three counties in the LENOWISCO Planning District see the highest incidence of  
 4 Campylobacteriosis. [According to the CDC](#), there are about 1.5 million cases of  
 5 Campylobacteriosis annually in the United States. It is often caused by eating raw or undercook  
 6 poultry or other meats, contact with animals, or drinking untreated or contaminated water.

7 **FIGURE: Top Communicable Disease by County, 2018**

8 **Source:** [Virginia Department of Health](#)

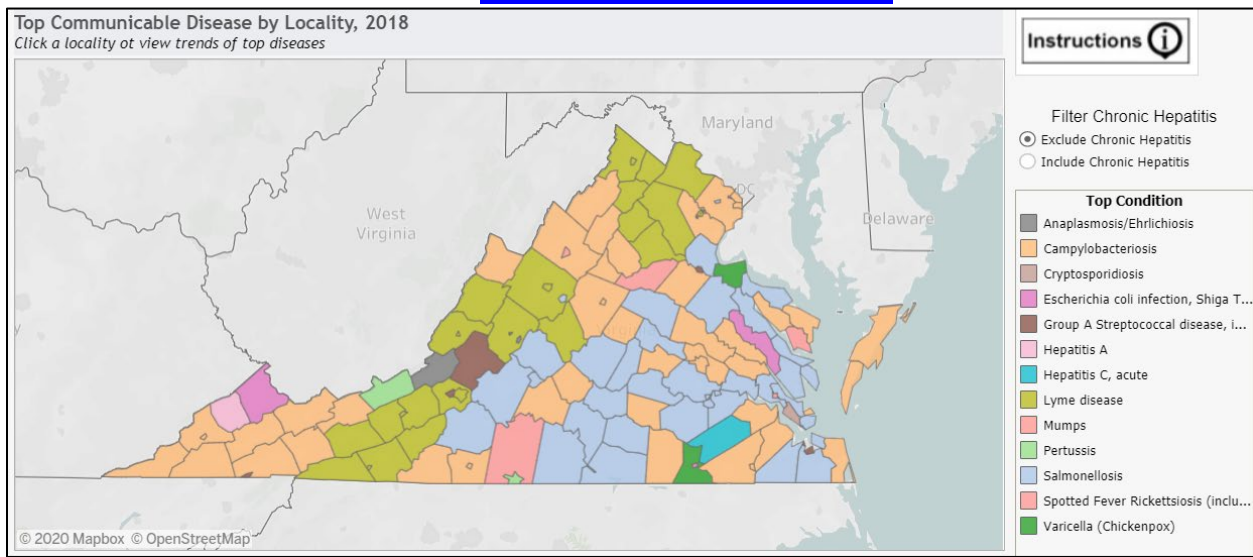

10 Additionally, the Virginia Department of Health tracks the ten most common communicable  
 11 diseases in each county each year, as illustrated in the figures below.

12 **FIGURE: Top 10 Communicable Diseases in Lee County, 2009-2017**

13 **Source:** [Virginia Department of Health](#)

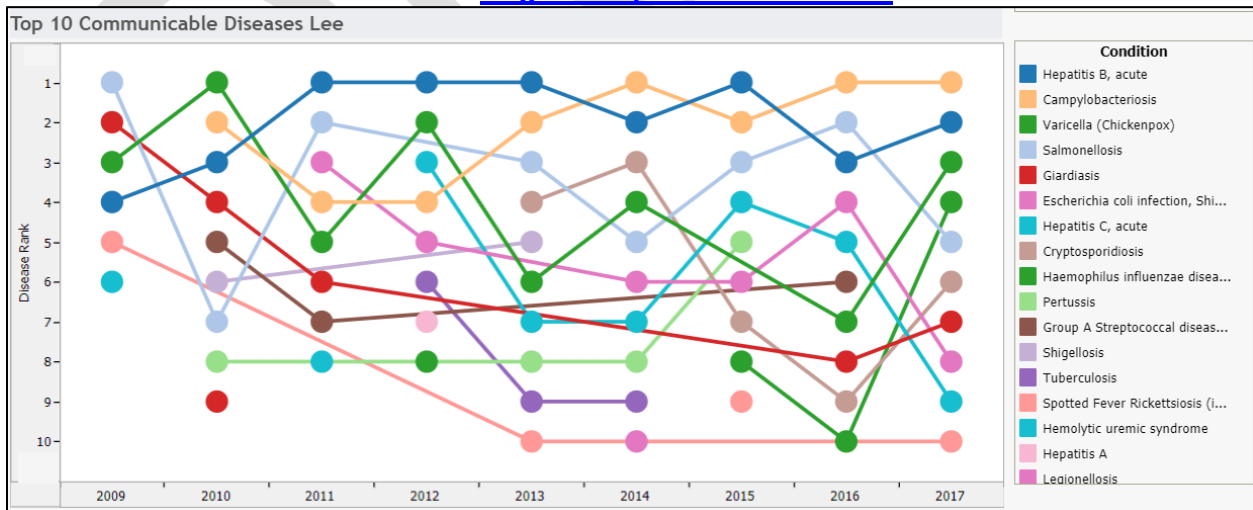



**FIGURE: Top 10 Communicable Diseases in Scott County, 2009-2017**

Source: [Virginia Department of Health](#)

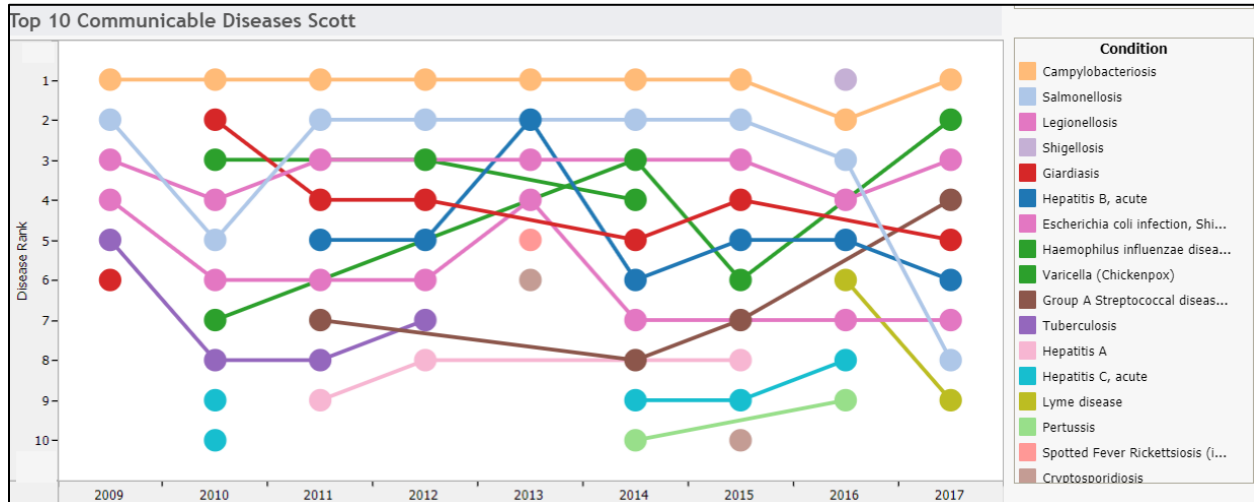

**FIGURE: Top 10 Communicable Diseases in Wise County, 2009-2017**

Source: [Virginia Department of Health](#)

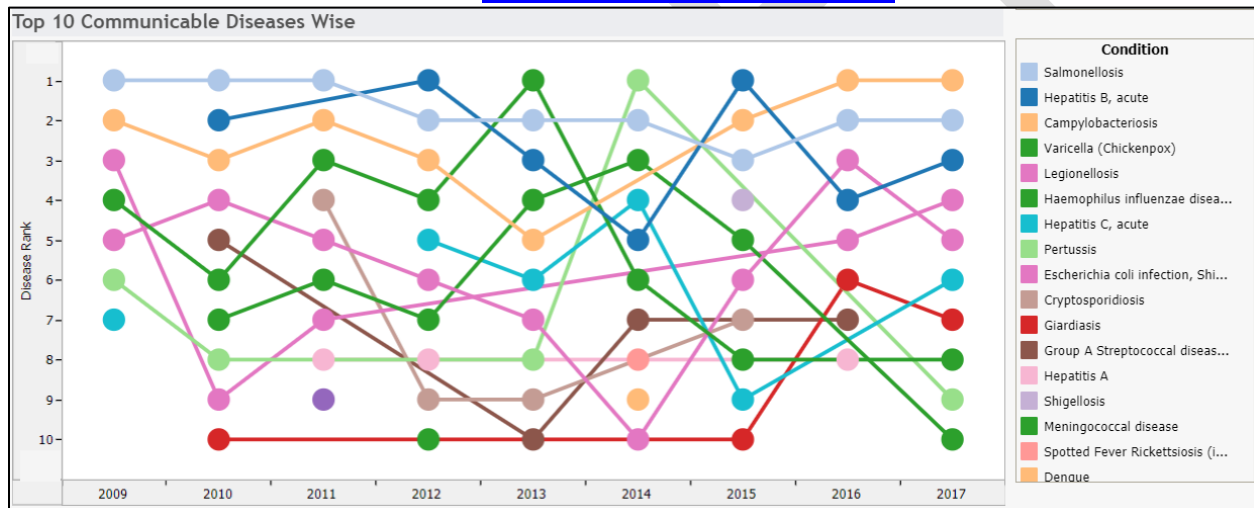

In addition to local communicable diseases, there have been five pandemics during the 20th and 21st centuries: 1918, 1957, 1968, 2009, and 2020.

- 1918 (Spanish Flu):** The 1918-1919 influenza pandemic was the most severe and deadliest in history. An estimated 500 million people, or 30% of the world's population, were infected with the virus. Approximately 675,000 Americans and at least 50 million people worldwide died from the virus. The virus was first identified in military personnel returning from World War I in the spring of 1918. There is no agreed-upon origin point for the virus, as mass troop movements likely contributed to its rapid spread. The pandemic was characterized by three distinct waves, peaking in the U.S. during the second wave in the fall of 1918 ([CDC](#)).
- 1957 (Asian Pandemic Flu-H2N2):** This new influenza virus first emerged in Singapore in February 1957, followed by Hong Kong, and U.S. coastal cities by the summer of that



- 1 year. An estimated 116,000 Americans and 1.1 million people worldwide died from the  
2 virus ([CDC](#)).
- 3 • **1968 (Hong Kong Flu-H3N2):** The strain of influenza leading to the 1968 pandemic led  
4 to more significant deaths in people 65 and older. First reaching the U.S. in September  
5 1968 from returning soldiers in Vietnam, the virus led to 1 million deaths worldwide and  
6 about 100,000 in the U.S. ([CDC](#)).
  - 7 • **2009 (Swine Flu-H1N1):** H1N1 was first detected in the United States in April  
8 2009. Nearly one-third of older people in the U.S. were found to have antibodies to this  
9 strain of H1N1, likely due to exposure to similar strains. The CDC estimates there were  
10 over 60 million cases and nearly a quarter-million hospitalizations in the U.S.  
11 Approximately 12,000 people died from the virus in the U.S., and between 151,000-  
12 575,000 worldwide, of which an estimated 80% were under the age of 65 ([CDC](#)).
  - 13 • **2020 (COVID-19):** As an ongoing pandemic at the time of this plan update, COVID-19 is  
14 described in-depth at the beginning of this profile.

DRAFT



1 Future Probability

2 Based on the Community Vulnerability Risk and Resiliency (CVR2) assessment, detailed in Section 1.6.13 (methodology) and  
 3 Section 1.6.14 (results), this hazard is **Somewhat Probable/Somewhat Frequent** because significant occurrences of this hazard  
 4 have happened on occasion (even though isolated or low impact events may occur with more regularity). The overall risk ranking for  
 5 this hazard is **Medium**.

6 The 2018 Commonwealth of Virginia Hazard Mitigation Plan (HMP) outlines a ranking of each jurisdiction in the LENOWISCO  
 7 Planning District based on various risk factors. Due to the unpredictability and localized impact of a public health emergency, the  
 8 HMP ranking parameters rely mostly on population size and density to determine risk. All jurisdictions in the District have a "Medium-  
 9 Low" ranking.

**TABLE: Communicable Disease Hazard Ranking Parameters**  
*Source: 2018 Commonwealth of Virginia Hazard Mitigation Plan*

Jurisdiction	Population Vulnerability	Population Density	Injuries & Fatalities	Property Damage	Crop Damage	Events	Geographic Extent	Total Risk Ranking
City of Norton	Low	Medium-High	Medium	Low	Low	Medium	Low	Medium-Low
Lee County	Medium	Low	Medium	Low	Low	Medium	Low	Medium-Low
Scott County	Medium	Low	Medium	Low	Low	Medium	Low	Medium-Low
Wise County	Medium	Medium	Medium	Low	Low	Medium	Low	Medium-Low



## 1 Geographic Location

2 There is no geographic location for this hazard, beyond that outbreaks typically begin in areas  
3 with high populations. In contrast to seasonal influenza when it occurs during the late fall and  
4 early winter months, pandemic influenza can occur during any month or season. In the case of  
5 COVID-19, higher density coastal cities experienced the earliest waves of the pandemic, but the  
6 following months included rising case counts in rural areas and smaller cities.

## 7 Loss Estimates

8 Global pandemic events can contribute to significant economic losses across all sectors and  
9 communities. Other communicable diseases can have an extensive impact on livestock  
10 operations which may be subject to disease outbreaks. Livestock and animal products account  
11 for more than 66% of agricultural sales in Virginia ([USDA](#)). The state regularly sees small  
12 outbreaks of vector-borne diseases, including Eastern Equine Encephalitis (EEE) and West Nile  
13 Virus (WNV). As recently as 2002, Virginia had an outbreak of avian influenza that caused  
14 significant impacts on poultry producers.

15 According to the 2017 Census of Agriculture, livestock, poultry, and products make up 74% of  
16 agricultural sales in [Lee County](#), 75% in [Scott County](#), and 66% in [Wise County](#). Given the  
17 importance of livestock to the local economy, a vector-borne illness leading to widespread  
18 animal losses could have significant economic impacts.

## 19 Vulnerability and Community Development Analysis

20 As the world experienced in 2020, public health emergencies (like a pandemic of influenza) will  
21 have a major impact on society. Public health emergencies, especially those of longer duration,  
22 introduce stress to the healthcare system and can have rippling impacts on the local and  
23 national economy. Influenza and other communicable diseases can also lead to increases in  
24 health complications and pose a greater risk to older individuals and those with underlying  
25 health conditions. The actual impacts of an event will be highly dependent on the duration,  
26 scale, and location of the incident.

27 COVID-19 also exposed challenges in the United States with successfully introducing  
28 interventions to slow the spread of the virus. Inconsistent messaging at the local, state, and  
29 federal levels can leave residents confused or distrustful of public health recommendations. As  
30 of November 2020, various vaccines are under development for COVID-19. It is unclear how  
31 receptive people will be to a mass-vaccination effort, and there is growing concern among public  
32 health professionals given the growing movement of anti-vaccination, coupled with the rapid  
33 pace of development for COVID-19 in particular. According to EIPH, "The two public health  
34 interventions that have had the greatest impact on the world's health are clean water and  
35 vaccines. Vaccines have prevented serious illnesses and death for millions of children and  
36 adults every year. But there is still a long way to go. Immunizations, the most cost-effective  
37 public health intervention, continue to be under-used" ([EIPH](#)).

38 It is anticipated that this hazard will become more likely to occur in the future as the population  
39 increases. Additionally, any decline in immunization rates in the District and Commonwealth will  
40 increase the probability of an epidemic/pandemic. Currently, schools in the LENOWISCO  
41 Planning District [report](#) high immunization rates.





1 *Impact on LENOWISCO Residents*

2 Public health emergencies tend to have widespread impacts on many populations, but some  
3 residents are more at risk of complications than others. At-risk populations may include:

- 4 • Adults 65 years and older
- 5 • Pregnant women and women up to 2 weeks from the end of pregnancy
- 6 • People with chronic medical conditions (i.e. asthma, heart failure, chronic lung disease,  
7 obesity, etc.)
- 8 • People with compromised immune systems (i.e. diabetes, HIV, cancer, etc.)

9 Some communicable diseases may also pose a greater risk to children under 2 years old or  
10 people receiving certain medications or therapies. It is important to note that there are  
11 significant racial and ethnic disparities in the potential impact of a public health emergency.  
12 Inequities in the [social determinants of health](#) put some groups at increased risk of getting sick  
13 or dying, as was the case during the global COVID-19 pandemic ([CDC](#)). Some factors  
14 influencing this risk include:

- 15 • **Healthcare access and utilization:** those without access to adequate insurance, or  
16 those with limited access due to a lack of transportation, child care, the ability to take  
17 time off work, or language and cultural barriers.
- 18 • **Occupation:** people in "essential work settings" such as healthcare facilities, emergency  
19 operations, farms, factories, grocery stores, and public transportation will be in close  
20 contact with the public during a public health emergency. Additionally, individuals with  
21 limited paid sick days may feel pressured to come to work even if they are symptomatic  
22 or live with someone showing symptoms.
- 23 • **Education, income, and wealth gaps:** people with limited job options, due to lower  
24 school completion rates or barriers to college, have less flexibility to leave jobs that put  
25 them at greater risk of exposure. Individuals with lower incomes cannot afford to miss  
26 work and/or don't have adequate savings.
- 27 • **Housing:** people living in more crowded housing may find it more difficult to avoid close  
28 contact or exposure. Additionally, people with lower incomes are at risk of eviction,  
29 shared housing, or homelessness.

30 Even if a public health emergency originates outside of the LENOWISCO Planning District, the  
31 community may still experience impacts. Short-term or contained outbreaks will have limited  
32 impacts on the larger population or economy, although they can be devastating for those who  
33 become sick. A prolonged outbreak like COVID-19 can have significant impacts on both the  
34 local and national economy. As of [September 2020](#), the unemployment rate was 6.2% in  
35 Virginia and 7.9% nationwide. People are unable to work for extended periods of time, either  
36 because they are sick, caring for someone who was exposed, or quarantining due to potential  
37 exposure. Businesses may need to lay off or furlough parts of their workforce due to decreased  
38 visitation, tourism, or other economic factors.

39 An additional factor during a prolonged public health emergency is the impact on schools and  
40 school-age children. Families and the workforce depend on regular school schedules, but most  
41 schools across the country closed during the initial outbreak of COVID-19 in the spring of 2020,  
42 and some returned in the fall with hybrid or online learning, limited hours, or other scheduling  
43 changes. Children can serve as ready carriers of a virus or pathogen and may infect family



1 members, teachers, or other school staff. As of October 2020, the Virginia Department of Health  
 2 had recorded [five school outbreaks](#) in the LENOWISCO Planning District. Outbreaks may lead  
 3 to short-term closures, widespread quarantines, or other measures that impact the ability of  
 4 parents and staff to go to work or access other reliable childcare options.

5 Vaccination compliance is relatively high at school districts in the LENOWISCO Planning  
 6 District. In the fall of 2019, reporting school districts had vaccination coverage of 100% of  
 7 kindergartners in Norton, 86.7% in Lee County, 96.9% in Scott County, and 95.2% in Wise  
 8 County ([Virginia Department of Health](#)).

9 Based on these factors, there are several at-risk groups in the LENOWISCO Planning District,  
 10 including the elderly, people with disabilities, socio-economically disadvantaged individuals, and  
 11 people without health insurance.

**TABLE: Data Profile**  
*Source: American Community Survey, 2014-2018*

Area	Total Population	Disabled	Individuals in Poverty	Individuals Over 65 years old	Uninsured
City of Norton	3,990	23.6% (929)	29.4%	14.2% (689)	10.1%
Lee County	24,134	25.9% (5,859)	24%	19.7 % (4,759)	13.2% (2,981)
Scott County	22,009	24.8% (5,286)	18.6%	22.7% (4,999)	10.9% (2,320)
Wise County	39,025	26.9% (9886)	22%	16.9% (6,583)	11.1% (4,082)

12

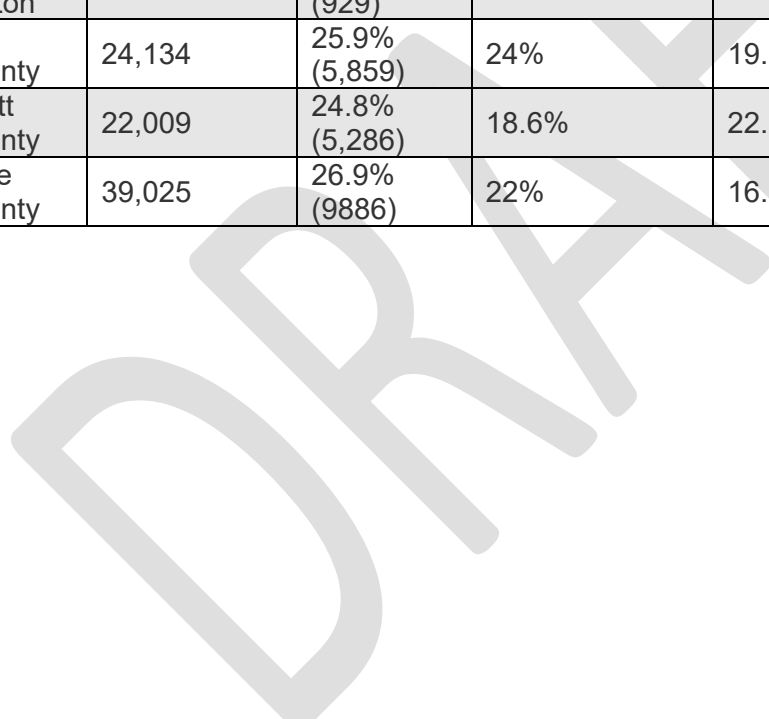



- 1 Additionally, certain industries are more at risk from the impacts of a prolonged public health emergency, including retail trade;
- 2 educational services, and health care and social assistance; and arts, entertainment, and recreation, and accommodation and food
- 3 services. Collectively, these three sectors make up 49.3% of the workforce in Lee County, 42% in Scott County, 46.2% in Wise
- 4 County, and 52.8% in the City of Norton.

**TABLE: Data Profile**  
**Source: American Community Survey, 2014-2018**

Industry	Lee County		Scott County		Wise County		City of Norton	
	Estimate	Percent	Estimate	Percent	Estimate	Percent	Estimate	Percent
Civilian employed population 16 years and over	7474		8340		13075		1539	
Agriculture, forestry, fishing and hunting, and mining	362	4.8%	235	2.8%	916	7%	93	6%
Construction	576	7.7%	832	10%	591	4.5%	33	2.1%
Manufacturing	905	12.1%	1467	17.6%	715	5.5%	141	9.2%
Wholesale trade	108	1.4%	65	0.8%	259	2%	0	0%
Retail trade	1209	16.2%	1032	12.4%	1840	14.1%	319	20.7%
Transportation and warehousing, and utilities	326	4.4%	236	2.8%	653	5%	20	1.3%
Information	27	0.4%	183	2.2%	122	0.9%	19	1.2%
Finance and insurance, and real estate and rental and leasing	257	3.4%	194	2.3%	512	3.9%	0	0%
Professional, scientific, and management, and administrative and waste management services	388	5.2%	975	11.7%	1368	10.5%	212	13.8%
Educational services, and health care and social assistance	2039	27.3%	2044	24.5%	3092	23.6%	383	24.9%
Arts, entertainment, and recreation, and accommodation and food services	434	5.8%	429	5.1%	1105	8.5%	111	7.2%
Other services, except public administration	363	4.9%	281	3.4%	683	5.2%	104	6.8%
Public administration	480	6.4%	367	4.4%	1219	9.3%	104	6.8%



1 ***Impact on Essential Facilities, Critical Infrastructure, and Future Assets***

2 Essential facilities will not be physically impacted by this hazard. They may be impacted by the  
3 loss of workers who are ill or need to care for others who are ill. The LENOWISCO Health  
4 District includes three health departments, Lee County Health Department, Wise County and  
5 City of Norton Health Department, and the Scott County Health Department. There are four  
6 hospitals in the district, including Lonesome Pine Hospital (Big Stone Gap), Norton Community  
7 Hospital (Norton), Mountain View Regional Hospital (Norton), and Lee County Hospital  
8 (Pennington Gap).

9 The greatest risk to critical infrastructure is the availability of personnel to properly maintain and  
10 operate infrastructure. The staff themselves may become ill, or need to attend to family  
11 members or others who are ill. Additionally, jurisdictions and companies responsible for  
12 managing critical infrastructure will need to have adequate protocols in place to protect workers  
13 from exposure while at work.

14 No future assets/infrastructure are exposed to damage due to a public health emergency;  
15 however, absenteeism and resource shortages can impact the maintenance of assets.

16 ***Impact on the Environment***

17 The Virginia Department of Wildlife Resources manages a list of wildlife diseases. It is important  
18 to note is that many diseases impacting wildlife do not impact humans or impact in the same  
19 way. See the full list on the [Virginia Department of Wildlife Resources website](#).

20 While a public health emergency does not have immediate effects on the environment, a  
21 prolonged event like that of COVID-19 can lead to more limited resources and staffing for  
22 important environmental management activities. Public agencies responsible for water quality  
23 testing, parks and open space management, and other essential services may face resource  
24 limitations or budget cuts that restrict these activities.

25 ***Impact on Operations***

26 A public health emergency can have significant impacts on the availability of first responders,  
27 healthcare personnel, and other emergency operations staff. These professionals can be easily  
28 exposed to pathogens or individuals carrying a virus, especially if there is not sufficient personal  
29 protective equipment (PPE) available or there are not adequate PPE protocols in place. Local  
30 hospitals and care facilities may experience a rapid increase in patients seeking care, potentially  
31 overwhelming capabilities, and requiring state or federal aid.

32



1 Hazard Evaluation and Impact/Consequence Assessment

Frequency & Probability <sup>1</sup>	Somewhat Vulnerable
Potential Magnitude and Scale <sup>1</sup>	Somewhat Vulnerable
Physical Vulnerability Hazard Impact <sup>1</sup>	Somewhat Vulnerable
Social Vulnerability Hazard Impact <sup>1</sup>	Vulnerable
Community Conditions Hazard Impact <sup>1</sup>	Vulnerable
Overall Capability and Capacity <sup>2</sup>	Somewhat Capable
Mitigation <sup>2</sup>	Somewhat Capable
Hazard Consequence & Impact Score <sup>1</sup>	Vulnerable
Overall Risk Rating <sup>3</sup>	Medium

Legend			
Score	1: Vulnerability Rating	2: Capability and Capacity Rating	3: Overall Risk Rating
0 – 24	Minimally Vulnerable	Minimally Capable	Low
25 – 49	Somewhat Vulnerable	Somewhat Capable	Medium
50 – 74	Vulnerable	Capable	High
75 - 100	Very Vulnerable	Very Capable	Extreme
N/A	Not Applicable/Unknown	Not Applicable/Unknown	Not Applicable/Unknown

2

3

DRAFT





## 1 1.6.2 Dam Failure

2 A dam failure is defined as an uncontrolled release of a reservoir. The causes of dam failures  
3 can be divided into three groups: dam overtopping, excessive seepage, and structural failure of  
4 a component. Despite efforts to provide sufficient structural integrity and to perform inspection  
5 and maintenance, problems can develop that can lead to failure. While most dams have storage  
6 volumes small enough that failures have little or no repercussions, dams with large storage  
7 amounts can cause significant flooding downstream. Dam failures can result from any one or a  
8 combination of the following causes:

- 9 • Prolonged periods of rainfall and flooding, which cause most failures.
- 10 • Inadequate spillway capacity, resulting in excess overtopping flows.
- 11 • Internal erosion caused by embankment or foundation leakage or piping.
- 12 • Improper maintenance, including failure to remove trees, repair internal seepage  
13 problems, replace lost material from the cross-section of the dam and abutments, or  
14 maintain gates, valves, and other operational components.
- 15 • Improper design, including the use of improper construction materials and construction  
16 practices.
- 17 • Negligent operations, including the failure to remove or open gates or valves during high  
18 flow periods.
- 19 • Failure of upstream dams in the same waterway.
- 20 • Landslides into reservoirs, which cause surges that result in overtopping
- 21 • High winds, which can cause significant wave action and result in substantial erosion;  
22 and
- 23 • Earthquakes, which typically cause longitudinal cracks at the tops of the embankments,  
24 can weaken entire structures.

25 Dams are complicated structures, and it can be difficult to predict how a structure will respond to  
26 distress. As stated in the Safety of Existing Dams, "... the modes and causes of failure are  
27 varied, multiple, and often complex and interrelated, i.e., often the triggering cause may not truly  
28 have resulted in failure had the dam not had a secondary weakness. These causes illustrate the  
29 need for careful, critical review of all facets of a dam" (Safety of Existing Dams, 1983).

30 More than a third of the nation's dams are already 50 years old. About 14,000 of those dams  
31 pose a "high" or "significant" hazard to life and property if a failure occurs. There are also about  
32 2,000 "unsafe" dams in the United States and in almost every state.

- 33 • Communities downstream of a dam
- 34 • Communities reliant on levee systems for protection

35 Dams can fail with little warning. Intense storms may produce flooding in a few hours or even  
36 minutes for upstream locations. Flash floods can occur within six hours of the beginning of  
37 heavy rainfall, and dam failure may occur within hours of the first signs of breaching. Other  
38 failures and breaches can take much longer to occur, from days to weeks, as a result of debris  
39 jams, the accumulation of melting snow, the build-up of water pressure on a dam with  
40 (unknown) deficiencies after days of heavy rain, etc. Flooding can also occur when a dam  
41 operator releases excess water downstream to relieve pressure from the dam.



1 There is no official number of how many dam failures have occurred in the United States.  
2 Between 2005 and 2013, state-run dam safety programs reported 173 dam failures and 587  
3 incidents at dams which, without intervention, may have led to a dam failure.  
4 Overtopping a dam is often a precursor to dam failure. National statistics show that overtopping  
5 due to inadequate spillway design, debris blockage of spillways or settlement of the dam crest  
6 account for approximately 34% of all U.S. dam failures.  
7 Another 20% of U.S. dam failures have been caused by piping (internal erosion caused by  
8 seepage). Seepage often occurs around hydraulic structures, such as pipes and spillways;  
9 through animal burrows; around roots of woody vegetation; and through cracks in dams, dam  
10 appurtenances, and dam foundations ([Association of State Dam Safety Officials](#)).

11 **FIGURE: Dam Failures in the United States**  
12 **Source: James S. Halgren, Office of Hydrologic Development, National Weather Service,**  
13 **National Oceanic and Atmospheric Administration**

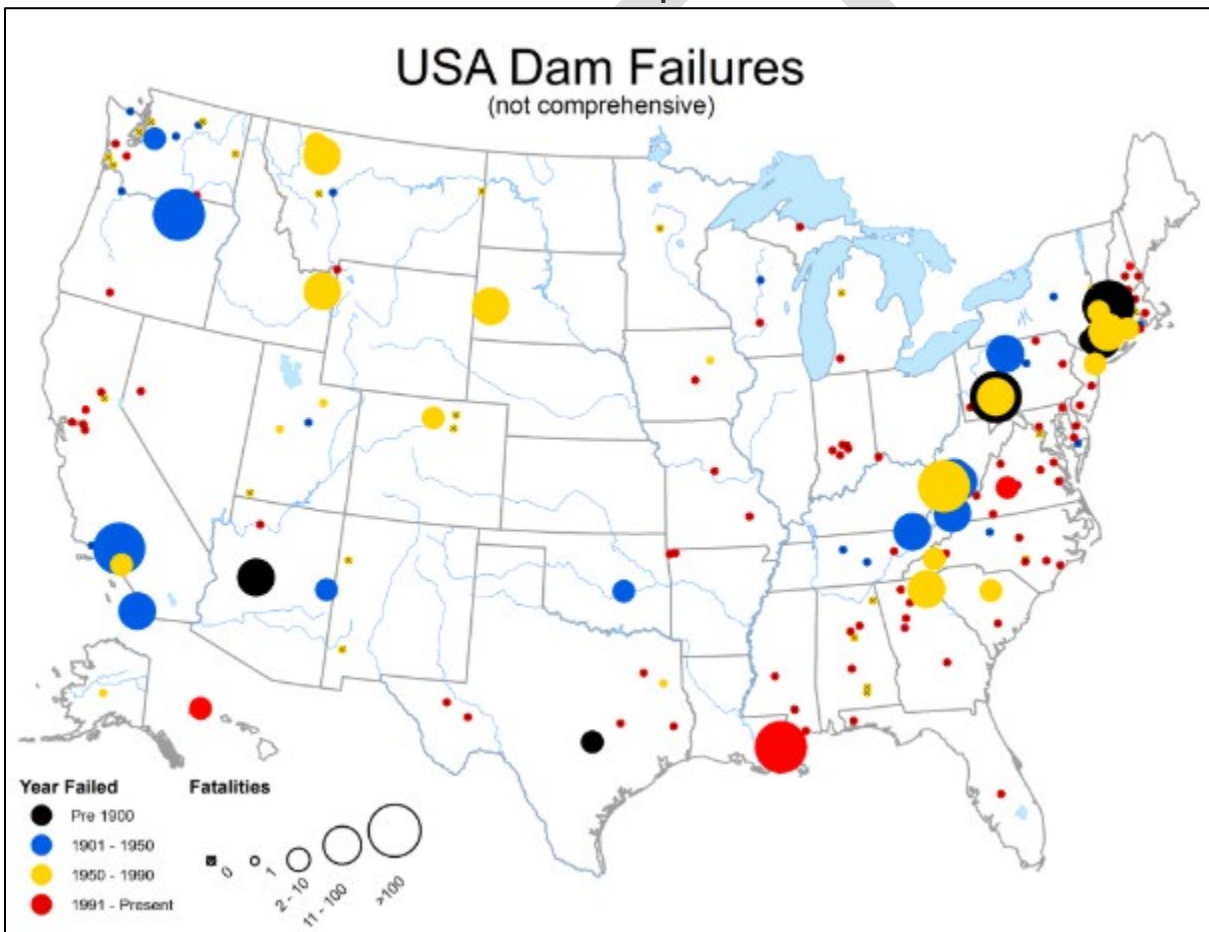

14  
15  
16



1 Hazard Extent

2 The Virginia Department of Conservation and Recreation (DCR) Division of Dam Safety and  
 3 Floodplain Management administers the Virginia Dam Safety Program. The Division regulates  
 4 impounding structures and conducts ongoing dam inspections to prevent dam failures. Dam  
 5 classification is based on potential downstream losses in the event of a failure and dictates  
 6 regulatory requirements such as frequency of inspection and design standards. Hazard potential  
 7 is not related to structural integrity.

**TABLE: Virginia Dam Classification Systems**  
*Source: Virginia Department of Conservation and Recreation*

Hazard Potential	Description	Inspection
High (Class I)	Failure will cause probable loss of life or serious economic damage (to buildings, facilities, major roadways, etc.)	Annual, with inspection by a professional engineer every 2 years.
Significant (Class II)	Failure may cause loss of human life or appreciable economic damage (to buildings, secondary roadways, etc.)	Annual, with inspection by a professional engineer every 3 years.
Low (Class III)	Failure would result in no expected loss of human life, and cause no more than minimal economic damage	Annual, with inspection by a professional engineer every 6 years.

8  
 9 The Commonwealth of Virginia HMP identifies 53 High Hazard (Class I) dams across the state,  
 10 including three in the LENOWISCO Planning District, as detailed in the table below.

**TABLE: Virginia High Hazard Dam Inventory**  
*Source: 2018 Commonwealth of Virginia Hazard Mitigation Plan*

Jurisdiction	Dam Name	Dam Operator	Water Reservoir Name	Water Reservoir Location
City of Norton	Lower Norton Reservoir Dam	City of Norton	Lower Norton Reservoir	City of Norton
City of Norton	Upper Norton Reservoir Dam	City of Norton	Upper Norton Reservoir	City of Norton
Wise County	Bear Creek Dam	Town of Wise	Wise Reservoir	Wise County

11  
 12 History/Previous Occurrences

13 There are no recorded dam failures in the LENOWISCO Planning District. The Commonwealth  
 14 of Virginia does not manage a database of historic dam failures or flooding due to a dam failure.  
 15 Most failures in the state occur due to a lack of maintenance combined with significant  
 16 precipitation events.



1 Future Probability

2 Based on the Community Vulnerability Risk and Resiliency (CVR2) assessment, detailed in  
3 Section 1.6.13 (methodology) and Section 1.6.14 (results), this hazard is **Minimally**  
4 **Probably/Minimally Frequent**, because this hazard was determined to be extremely rare with  
5 little to no documented history of significant occurrences or events. While it is possible that low  
6 impact events may occur on occasion, the hazard’s overall impact on the District and  
7 participating jurisdictions would be very minor. The overall risk ranking for this hazard is **Low**.

8 Digital mapping of flood inundation areas due to impoundment/dam failure is not currently  
9 available in digital form. Risk assessment and future probability are based on dam location and  
10 classification. As noted in the 2018 Commonwealth of Virginia HMP, assessing the probability of  
11 flooding due to dam failure is a site-specific endeavor and relates to detailed regulatory  
12 requirements based on design performance standards.

13 While no flooding events due to impoundment failure have been recorded in the LENOWISCO  
14 Planning District, understanding the location and risk for the county associated with dams and  
15 levees is vital. In the broader U.S., the average age of a dam is 57 years and 74% of these  
16 dams are considered "High Hazard Potential Dams" as defined by the National Inventory of  
17 Dams and require an Emergency Action Plan (EAP).

18 Geographic Location

19 According to the National Inventory of Dams, there are 23 dams in the LENOWISCO Planning  
20 District, as illustrated in the figure below.

21 **FIGURE: Dams in the LENOWISCO Planning District**  
22 **Source: [National Inventory of Dams](#)**

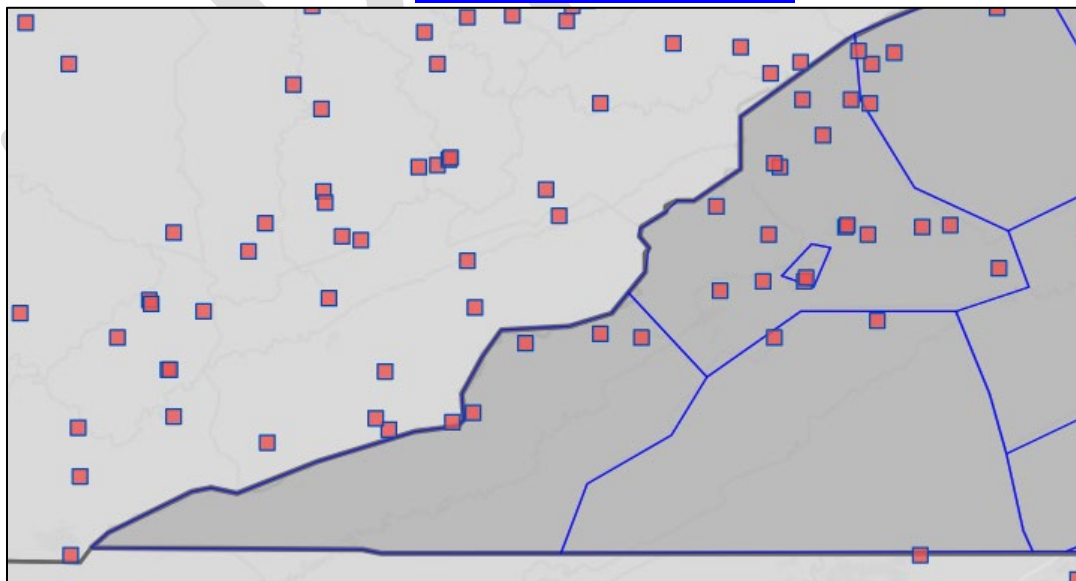

23  
24



1 Hazard ratings are set for all large dams. The "hazard" rating is not based on the physical  
2 attributes, quality, or strength of the dam itself, but rather the potential for loss of life or property  
3 damage should the dam fail. A dam is assigned a rating of High Hazard when its failure would  
4 probably put lives at risk. Dams with a "High" Hazard Potential Rating are required to have  
5 an EAP. Of the 11 dams with a "High" Hazard Potential Rating, eight have an EAP, and three  
6 do not have an EAP, as depicted in the maps below.

7 **FIGURE: Dams in the LENOWISCO Planning District with an EAP**

8 **Source: [National Inventory of Dams](#)**

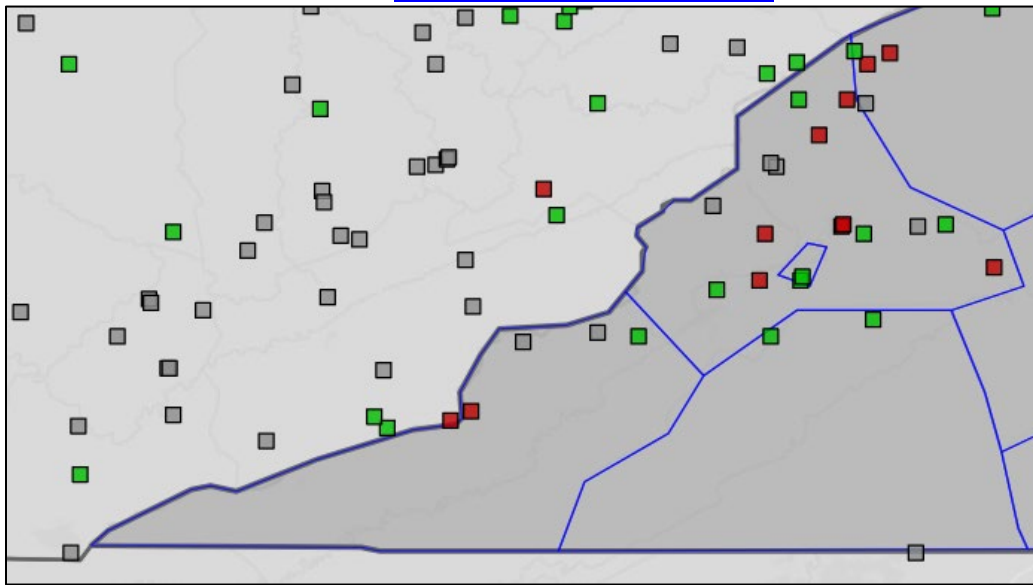

9  
10 (Green = completed EAP, Red = no completed EAP, Grey = EAP not required)

11 **FIGURE: Dams in the LENOWISCO Planning District by Hazard Potential**

12 **Source: [National Inventory of Dams](#)**

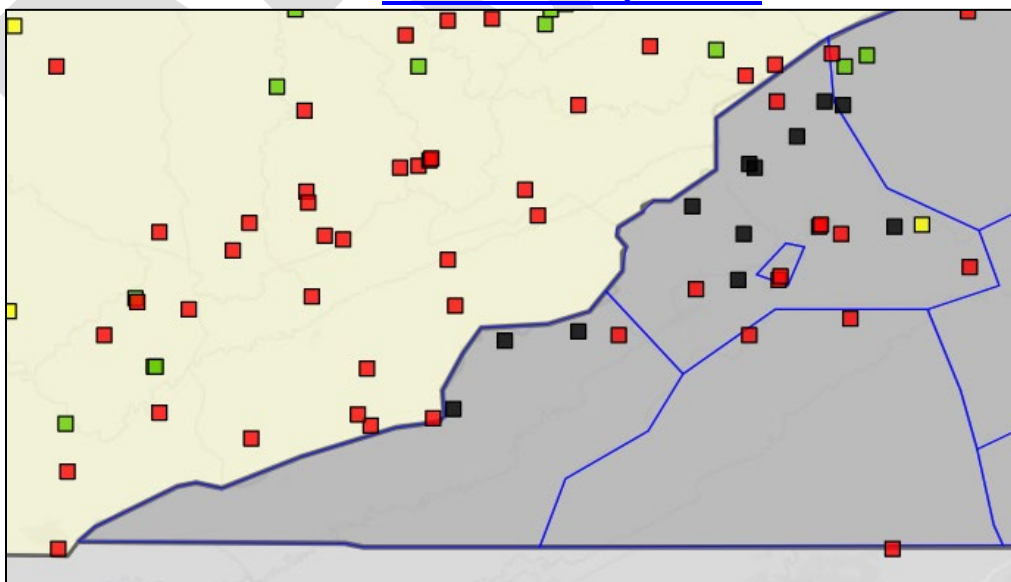

13  
14  
15 (Red = High Hazard Potential, Yellow = Significant Hazard Potential, Black = Undetermined)





- 1
- 2 In addition to hazard potential and EAP, the National Inventory of Dams captures dam ownership and regulatory bodies, dam type, structural details, and reported inspection dates. A summary of dams in the LENOWISCO Planning District is included in the table below, followed by a more detailed table including all characteristics for the 23 dams.
- 3
- 4

**TABLE: Summary of Dams in the LENOWISCO Planning District**  
*Source: National Inventory of Dams*

Jurisdiction	Total Dams	Average Age of Dam	% of High Hazard Potential Dams with an Emergency Action Plan	Percent of Dams Regulated by State Agency	Percent of Dams Regulated by a Federal Agency	Percent of Dams with Hydropower
City of Norton	2	N/A	100%	100%	0%	0%
Lee County	4	N/A	100%	50%	0%	50%
Scott County	1	N/A	100%	100%	0%	0%
Wise County	16	41	57%	69%	19%	6%

5





**TABLE: Dams in the LENOWISCO Planning District**  
 Source: National Inventory of Dams

Name	National ID#	Water Course	County/City	Owner	Year Completed	Hazard Potential	EAP	State Regulated	Last Inspection	Purpose
MIDDLETON DAM (10500DD045)	VA105001	STONE CREEK	LEE	STEVE MIDDLETON (Private)	Not Reported	Undetermined	No	Yes	Not Reported	Recreation
MILLER COVE SLURRY IMPOUNDMENT DAM	VA105004	Not Reported	LEE	Not Reported	Not Reported	Undetermined	Not Required	No	Not Reported	Not Reported
CALVIN PROJECT SLURRY DAM	VA105005	Not Reported	LEE	Not Reported	Not Reported	Undetermined	Not Required	No	Not Reported	Not Reported
KEOKEE DAM	VA105002	NORTH FORK POWELL RIVER	LEE	VIRGINIA DEPARTMENT OF GAME AND INLAND FISHERIES (State)	Not Reported	High	Yes	Yes	Not Reported	Recreation
UPPER NORTON RESERVOIR DAM	VA720002	BENGES BRANCH POWELL RIVER	NORTON CITY	CITY OF NORTON (Local Government)	Not Reported	High	Yes	Yes	Not Reported	Recreation
LOWER NORTON RESERVOIR DAM	VA720001	BENGES BRANCH POWELL RIVER	NORTON CITY	CITY OF NORTON (Local Government)	Not Reported	High	Yes	Yes	Not Reported	Water Supply
BARK CAMP DAM (CORDER BOTTOM LAKE)	VA169001	LITTLE STONY CREEK	SCOTT	VIRGINIA DEPARTMENT OF GAME AND INLAND FISHERIES (State)	Not Reported	High	Yes	Yes	Not Reported	Recreation
BENS BRANCH DAM	VA195009	BENS BRANCH	WISE	TOWN OF APPALACHIA (Local Government)	Not Reported	High	Yes	Yes	Not Reported	Water Supply
RIMROCK LAKE DAM	VA195012	POWELL RIVER	WISE	G. W. BARNETTE (Private)	1962	Undetermined	No	Yes	Not Reported	Recreation
BAND MILL HOLLOW FACILITY DAM	VA195007	-	WISE	Not Reported	Not Reported	Undetermined	Not Required	No	Not Reported	Not Reported
BLACK CREEK DAM (19500DD083)	VA195013	-	WISE	GREATER WISE, INC. (Private)	Not Reported	Undetermined	No	Yes	Not Reported	Recreation



DIXIANA MINE DAM	VA195005	GUEST RIVER	WISE	Not Reported	Not Reported	Undetermined	Not Required	No	Not Reported	Water Supply
STEER BRANCH DAM	VA195003	-	WISE	RED RIVER COAL COMPANY, INC. (Private)	Not Reported	Undetermined	Not Required	No	Not Reported	Other
N. FORK OF POUND DAM	VA195001	NORTH FORK OF POUND RIVER	WISE	CELRH (Federal)	1966	High	Yes	No	8/24/2016	Flood Control
INDIAN RIDGE POND DAM	VA195019	TR- POUND RIVER	WISE	Not Reported	Not Reported	Undetermined	No	Yes	Not Reported	Recreation
MCFALL FORK DAM	VA195020	TR- POUND RIVER	WISE	Not Reported	Not Reported	Undetermined	No	Yes	Not Reported	Recreation
UVA WISE #1 DAM	VA195017	YELLOW CREEK	WISE	UVA - COLLEGE AT WISE (State)	Not Reported	High	No	Yes	Not Reported	Recreation
UVA WISE #2 DAM	VA195018	YELLOW CREEK	WISE	UVA - COLLEGE AT WISE (State)	Not Reported	High	No	Yes	Not Reported	Recreation
BEAR CREEK DAM (WISE RESERVOIR)	VA195011	TR- BEAR CREEK	WISE	TOWN OF WISE (Local Government)	Not Reported	High	Yes	Yes	Not Reported	Recreation
SALIES BRANCH SLURRY IMPOUNDMENT DAM	VA195027	-	WISE	PARAMONT CONTURA, LLC (Private)	Not Reported	Undetermined	No	No	Not Reported	Tailings
TOMS CREEK DAM	VA195010	TOMS CREEK	WISE	TOWN OF COEBURN (Local Government)	Not Reported	Significant	Yes	Yes	Not Reported	Water Supply
DOMINION GENERATION VA CITY DAM #2	VA195025	MEADE CREEK	WISE	VIRGINIA ELECTRIC AND POWER COMPANY (Public Utility)	Not Reported	High	No	Yes	Not Reported	Flood Control
BIG CHERRY RCC DAM	VA195016	SOUTH FORK POWELL RIVER	WISE	TOWN OF BIG STONE GAP (Local Government)	2002	High	Yes	Yes	Not Reported	Water Supply



1 Loss Estimates

2 There is not currently a reliable method to calculate annualized losses due to dam failure in  
3 Virginia. Vulnerability, and thus potential losses, is based on the nature of downstream  
4 development and the operations and design of the dam itself. Losses due to dam failure could  
5 include loss of life, property damage, infrastructure disruption, and environmental impacts.

6 Vulnerability and Community Development Analysis

7 Most of the previously described causes for dam failure can be controlled through good design,  
8 proper construction, regular inspection by qualified personnel, and a commitment to strong  
9 enforcement to correct identified deficiencies. Dam failure vulnerability is dependent on the  
10 nature of downstream development and operations planning.

11 To reduce hazard potential, land downstream of new dams, or in the vicinity of existing canals,  
12 can be zoned or otherwise regulated to limit new construction and exposure. Public awareness  
13 measures, such as public education on dam safety, are proactive mitigation measures that  
14 should be implemented by local communities. Emergency Action Plans (EAPs) must be  
15 completed for the three dams located in Wise County that have a "High" Hazard Potential  
16 Ranking and no EAP. These dams include UVA-Wise #1 Dam, UVA-Wise #2 Dam, and  
17 Dominion Generation VA City Dam #2. Requests should be made to have Hazard Potential  
18 Rankings given to all the dams that currently do not have one. The EAP establishes potential  
19 dam failure inundation limits, notification procedures, and thresholds.

20 The risk to downstream assets and infrastructure can be reduced substantially with efforts to  
21 limit some types of development adjacent to streams and rivers. Additionally, none of the dams  
22 have an inspection date listed and only two have a completion year provided on the National  
23 Dam Inventory website. As with all infrastructure, deterioration with no maintenance will occur  
24 and makes failure more likely. An inspection will track maintenance.

25 *Impact on LENOWISCO Residents*

26 Public health risks are associated with dam failures. Particular for the LENOWISCO Planning  
27 District is the concern of pesticides utilized in crop control and the potential impact of drinking  
28 water supply. Additionally, the risks associated with flooding would apply if a dam failure  
29 occurred.

30 *Impact on Essential Facilities, Critical Infrastructure, and Future Assets*

31 The National Dam Safety Program was started in response to the catastrophic dam failures in  
32 the 1970s. Any structures located in the inundation area for a particular dam are at risk of  
33 catastrophic damages. Data is not currently available to identify essential facilities or critical  
34 infrastructure located in a dam inundation area in Virginia.

35 *Impact on the Environment*

36 Hundreds of dam failures have occurred throughout U.S. history. These failures have caused  
37 immense property and environmental damages and have taken thousands of lives. As the



1 nation's dams age and population increases, the potential for deadly dam failures can grow  
 2 without proper and routine maintenance.

3 **Impact on Operations**

4 Dam failures have the potential to highly impact operations and to prevent failures, more  
 5 coordination and communication are needed across agencies that regulate waterways, dams,  
 6 and land use.

7 **Hazard Evaluation and Impact/Consequence Assessment**

Frequency & Probability <sup>1</sup>	Minimally Vulnerable		
Potential Magnitude and Scale <sup>1</sup>	Somewhat Vulnerable		
Physical Vulnerability Hazard Impact <sup>1</sup>	Vulnerable		
Social Vulnerability Hazard Impact <sup>1</sup>	Vulnerable		
Community Conditions Hazard Impact <sup>1</sup>	Vulnerable		
Overall Capability and Capacity <sup>2</sup>	Somewhat Capable		
Mitigation <sup>2</sup>	Somewhat Capable		
Hazard Consequence & Impact Score <sup>1</sup>	Vulnerable		
Overall Risk Rating <sup>3</sup>	Low		
Legend			
Score	1: Vulnerability Rating	2: Capability and Capacity Rating	3: Overall Risk Rating
0 – 24	Minimally Vulnerable	Minimally Capable	Low
25 – 49	Somewhat Vulnerable	Somewhat Capable	Medium
50 – 74	Vulnerable	Capable	High
75 - 100	Very Vulnerable	Very Capable	Extreme
N/A	Not Applicable/Unknown	Not Applicable/Unknown	Not Applicable/Unknown

8





### 1 1.6.3 Drought

2 Droughts are characterized by either a short-term (seasonal) or long-term (several years)  
3 deficiency of precipitation. The resulting water shortages can impact important activities and  
4 environments, depending on the duration of the event. The water shortage is influenced not only  
5 by precipitation (amount, frequency, and intensity), but also by other factors including  
6 evaporation (which is increased by higher than normal heat and winds), transpiration, and  
7 human use. Human activities such as over farming, excessive irrigation, deforestation, and poor  
8 erosion controls can exacerbate a drought's effects. It can take weeks or months before the  
9 effects of below-average precipitation on bodies of water are observed. Depending on the  
10 region droughts can happen quicker, noticed sooner, or have their effects naturally mitigated.  
11 The more humid and wet an area is, the quicker the effects will be realized.

12 Drought is a part of an expected cycle between more wet and more dry periods in any given  
13 region. There are several common types of droughts, including:

- 14 • **Meteorological:** Defined by the degree of dryness (as compared to an average) and the  
15 duration of the dry period. These are region-specific and only appropriate for regions  
16 characterized by year-round precipitation.
- 17 • **Hydrological:** Associated with the effects of periods of precipitation shortfalls (including  
18 snow) on the surface or subsurface water supply, e.g. streamflow, reservoir, and lake  
19 levels, and groundwater. Impacts of hydrological droughts do not emerge as quickly as  
20 meteorological and agricultural droughts. For example, a deficiency of reservoir levels  
21 may not affect hydroelectric power production or recreational uses for many months.
- 22 • **Agricultural:** Links characteristics of meteorological or hydrological drought to  
23 agricultural impacts. An agricultural drought accounts for the variable susceptibility of  
24 crops during different stages of crop development from emergence to maturity.
- 25 • **Socioeconomic:** Links the supply and demand of some economic good, e.g. water,  
26 forage, food grains, and fish, with elements of meteorological, hydrological, or  
27 agricultural droughts. This type of drought occurs when demand for an economic good  
28 exceeds supply as a result of a weather-related shortfall in the water supply.

29 Droughts can occur in any part of Virginia, with the most common type being agricultural  
30 droughts. The following figure illustrates the sequence of three drought types (meteorological,  
31 agricultural, and hydrological) and their impacts.

32



**FIGURE: Sequence and Impact of Common Drought Types**

Source: [National Drought Mitigation Center](#)

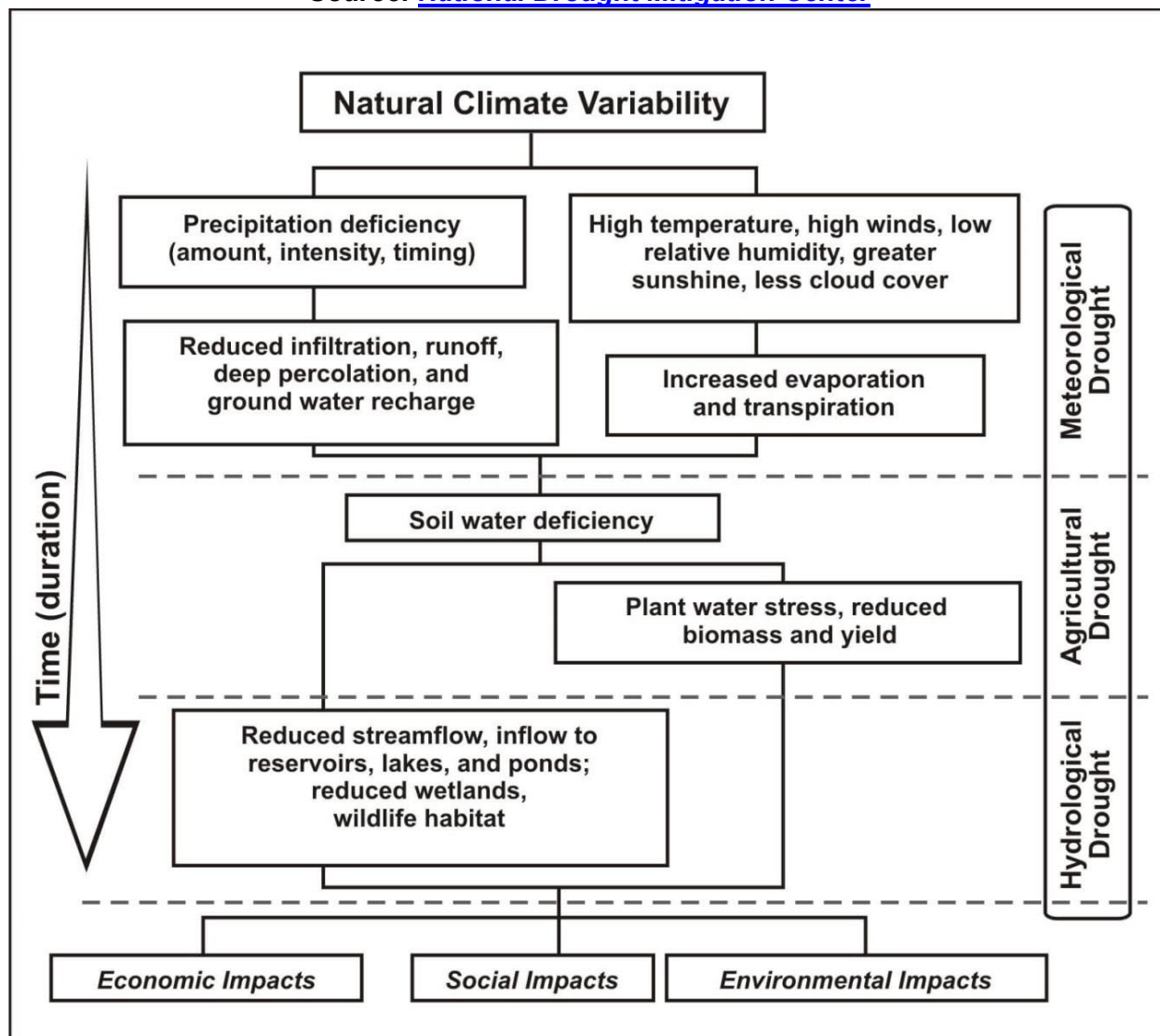

Hazard Extent

Droughts can last weeks, months, or years and they occur frequently in the United States, however, they are a “slow-onset” event and require long periods of below-average rainfall. The severity of the drought depends upon the degree of moisture deficiency, the duration, and the size of the affected area.

Droughts in the U.S. are classified based on the Palmer Drought Index, which uses several possible factors to determine the true severity of a drought. The range of the index is D1 to D4, where D4 represents the most damaging and severe drought. The index value of D0 is occasionally used to denote when a region is at risk from a drought in the near future. The table below from the United States Drought Monitor (USDM) shows the details behind these ratings:



**TABLE: Drought Classification**  
 Source: *U.S. Drought Monitor*

Category	Description	Possible Impacts	Palmer Drought Index	CPC Soil Moisture Model (Percentiles)	USGS Weekly Streamflow (Percentiles)	Standardized Precipitation Index (SPI)	Objective Short and Long-term Drought Indicator Blends (Percentiles)
D0	Abnormally Dry	Going into drought: short-term dryness slowing planting, growth of crops or pastures. Coming out of drought: some lingering water deficits; pastures or crops not fully recovered	-1.0 to -1.9	21-30%	21-30%	-0.5 to -0.7	21-30%
D1	Moderate Drought	Some damage to crops, pastures; streams, reservoirs, or wells low, some water shortages developing or imminent; voluntary water-use restrictions requested	-2.0 to -2.9	11-20%	11-20%	-0.8 to -1.2	11-20%
D2	Severe Drought	Crop or pasture losses likely; water shortages common; water restrictions imposed	-3.0 to -3.9	6-10%	6-10%	-1.3 to -1.5	6-10%
D3	Extreme Drought	Major crop/pasture losses; widespread water shortages or restrictions	-4.0 to -4.9	3-5%	3-5%	-1.6 to -1.9	3-5%
D4	Exceptional Drought	Exceptional and widespread crop/pasture losses; shortages of water in reservoirs, streams, and wells creating water emergencies	-5.0 or less	0-2%	0-2%	-2.0 or less	0-2%



1 History/Previous Occurrences

2 According to the [National Centers for Environmental Information \(NCEI\) Storm Events](#)  
3 [Database](#), there were no drought events in the LENOWISCO Planning District between 1950-  
4 2020.

5 The U.S. Drought Monitor has monitored national drought conditions since 2000. Since 2000,  
6 the longest drought in Virginia took place between 2007-2009. Additionally, an intense period of  
7 drought occurred in the summer and fall of 2002, as illustrated in the figure below.

8 **FIGURE: Drought Area for Virginia, 2000-2020**  
9 **Source: [U.S. Drought Portal - Virginia](#)**

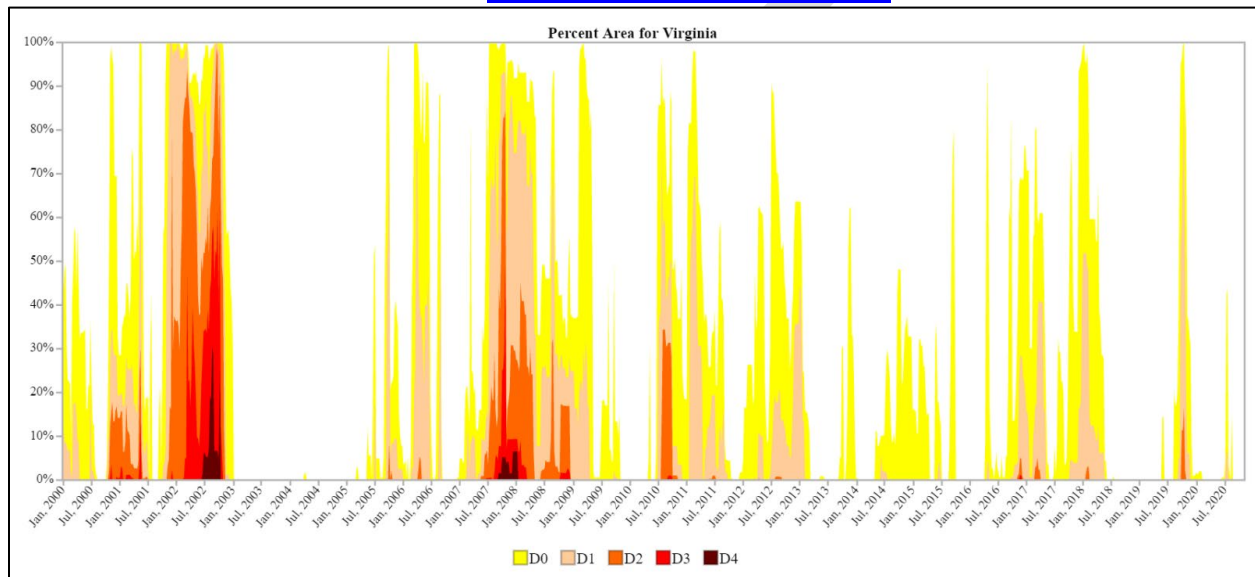

10  
11 In the LENOWISCO Planning District, drought periods have been similar to the state with less  
12 severity and duration. In recent years, the most significant drought event in the district was in  
13 late 2007 and early 2008. Short periods of "abnormally dry" conditions have occurred on an  
14 annual basis through the HMP planning period, with one short period of moderate-severe  
15 drought at the end of 2016.

16 **FIGURE: Historical Drought Conditions in the LENOWISCO Planning District, 2000-2020**  
17 **Source: [U.S. Drought Portal](#)**

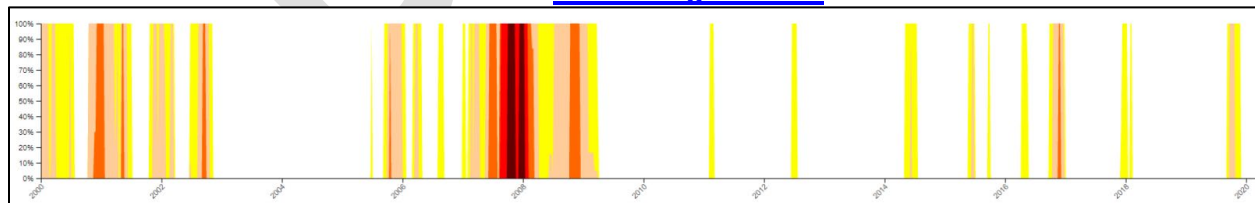

18  
19



**FIGURE: Drought Conditions in Virginia, December 2016**

Source: [U.S. Drought Portal](#)

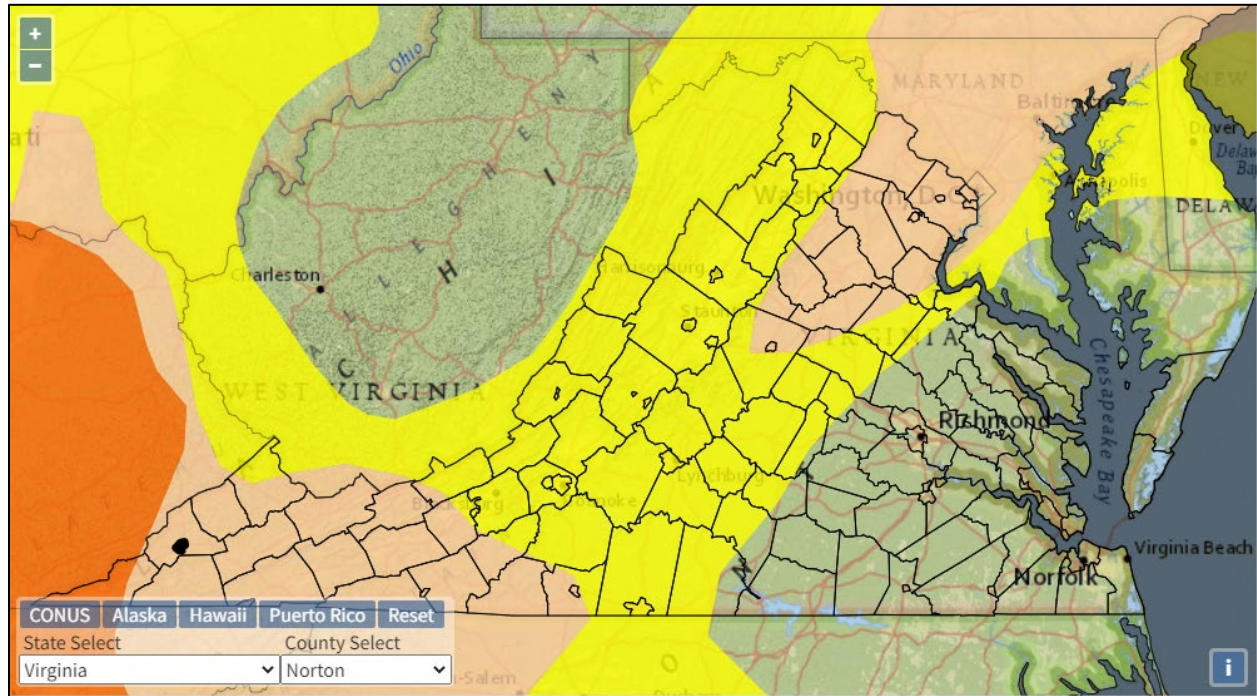

Other historic drought events impacting the LENOWISCO Planning District include:

- **1985-1988:** Severe drought in the entire southeastern US.
- **Early 2000s:** Throughout most of the early and mid-2000s the entire southeastern U.S. has been in varying levels of drought, including Virginia. In November 2002, 45 counties were approved for primary disaster designation by the US Secretary of Agriculture, while 36 requests were still pending. This dry period led to water conservation restrictions throughout the state and exacerbated water supply infrastructure problems, especially in rural communities.
- **October 2005:** A state of emergency was declared for the Town of Big Stone Gap when a combination of drought conditions and the construction of the Big Cherry Reservoir Dam resulted in a water shortage. The Commonwealth distributed \$1.3 million in funding to offset local emergency water supply operations.
- **2012-2013:** La Nina conditions produced extreme and exceptional drought conditions throughout much of the US, Canada, and Mexico. Peak drought conditions in July resulted in more than 80% of the country with at least abnormally dry conditions. For this event, much of Virginia was classified as either abnormally dry or as experiencing moderate to severe drought conditions.





1 Future Probability

2 Based on the Community Vulnerability Risk and Resiliency (CVR2) assessment, detailed in  
3 Section 1.6.13 (methodology) and Section 1.6.14 (results), this hazard is **Minimally**  
4 **Probably/Minimally Frequent**, because this hazard was determined to be extremely rare with  
5 little to no documented history of significant occurrences or events. While it is possible that low  
6 impact events may occur on occasion, the hazard’s overall impact on the District and  
7 participating jurisdictions would be very minor. The overall risk ranking for this hazard  
8 is **Medium**.

9 Drought events are not predictable, making it difficult to assess probability. Due to the historic  
10 presence of drought in the LENOWISCO Planning District, it is likely that some type of drought  
11 will occur in the future, but the duration, severity, and extent are more difficult to predict. USGS  
12 provides Drought Streamflow Probabilities for select rivers and streams in Virginia, including the  
13 Holston River near Gate City, the Powell River near Jonesville, and the Powell River at Big  
14 Stone Gap. Drought streamflow probabilities are projected for the summer months (July-  
15 September) based on the measured streamflow during the previous winter months (October-  
16 February). The drought probability for July-September 2020, as shown in the figure below, was  
17 below 20% at all three monitoring locations within the LENOWISCO Planning District.

18 **FIGURE: Drought Streamflow Probabilities (July-September 2020)**

19 **Source:** <https://va.water.usgs.gov/webmap/drought/>

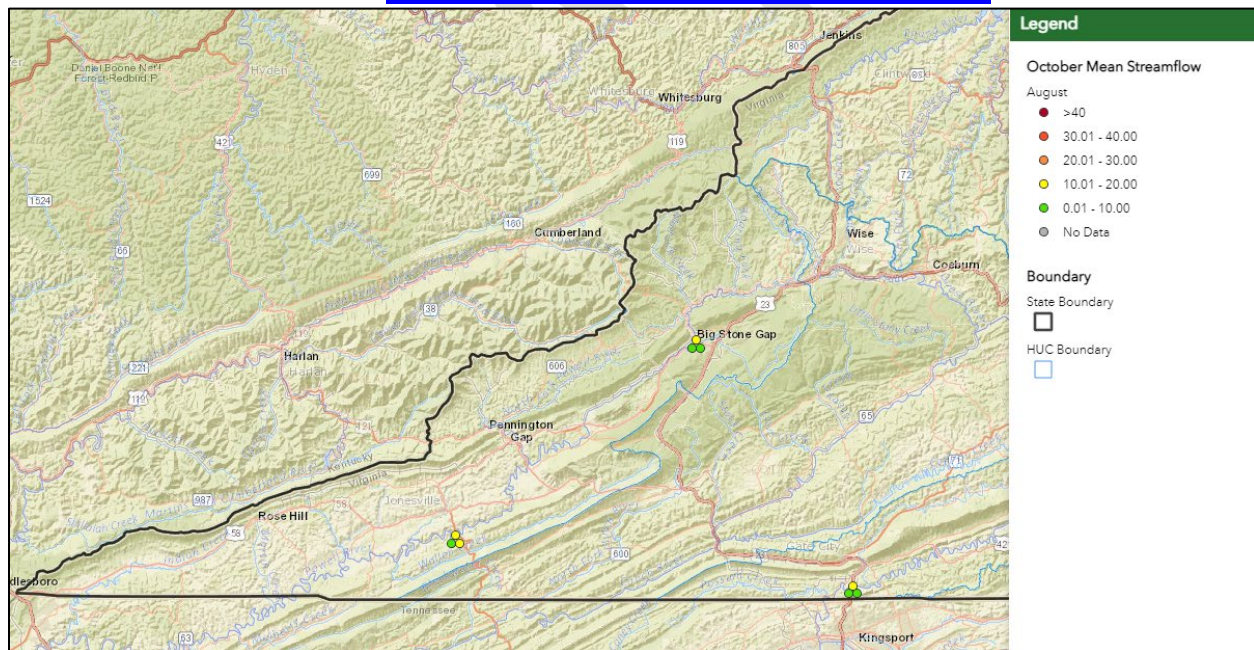

20  
21



1 Geographic Location

2 Communities rely on storms in the winter, and in some cases tropical systems in the summer,  
 3 for adequate rainfall. If rainfall levels are lacking, a drought can be called in any season.  
 4 Droughts are typically regional events and would impact all areas in the LENOWISCO Planning  
 5 District. Two observable signs of the water situation are streamflow and groundwater  
 6 status. The USGS monitors both through a network of river gauging stations and monitoring  
 7 wells.

8 The USGS WaterWatch database offers monthly streamflow maps to compare streamflow over  
 9 time. During the HMP analysis period (2015-2020), streamflows have increased from "normal"  
 10 in 2015 to "above normal" in 2020 in both winter and summer seasons. Below are comparative  
 11 maps from January and August. WaterWatch also manages two well monitoring stations in the  
 12 LENOWISCO Planning District that offer information on current groundwater status.

13 **FIGURE: Comparison Streamflow Map (January 2015 to January 2020)**  
 14 *Source: USGS WaterWatch*

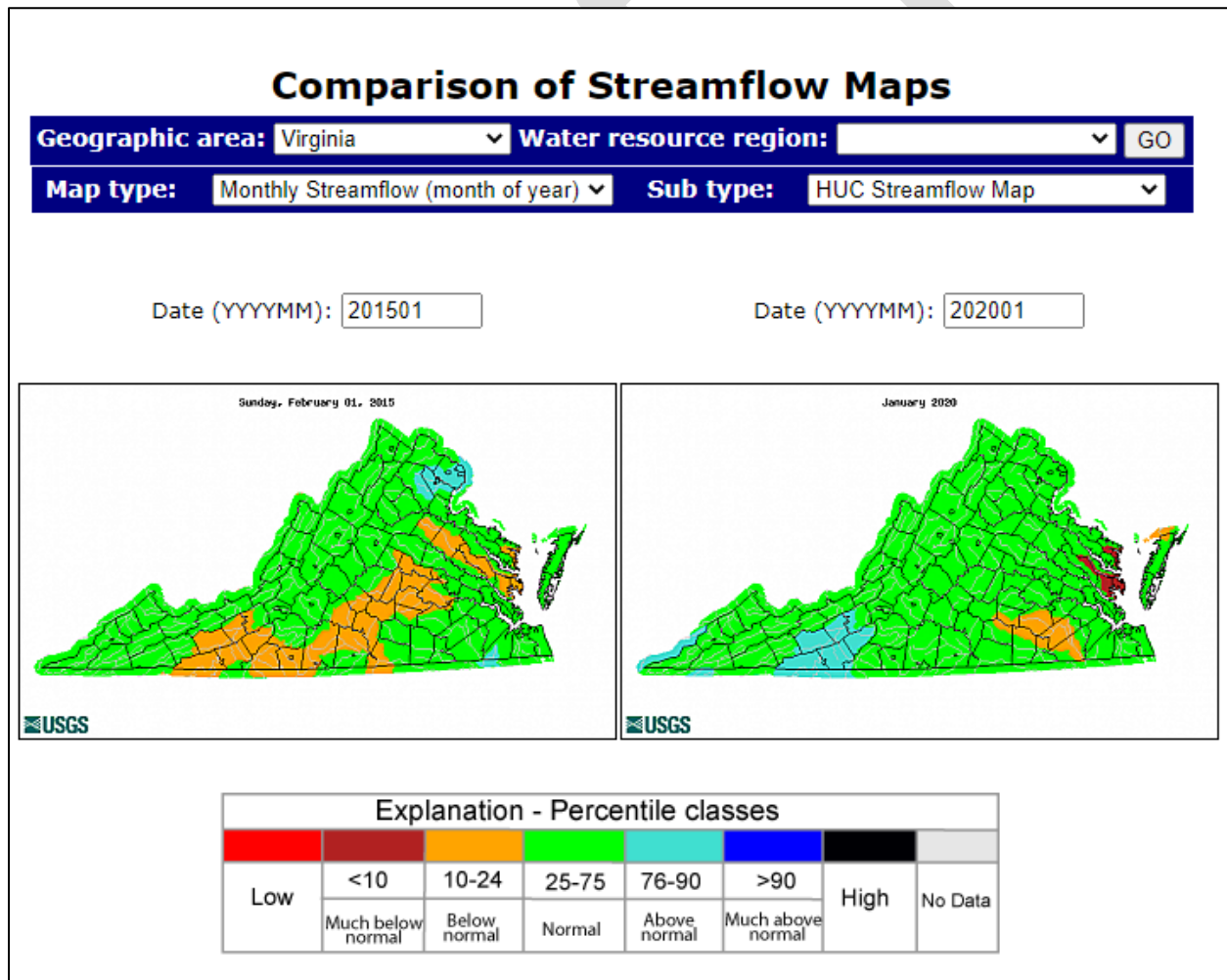

15  
 16



1  
2

**FIGURE: Comparison Streamflow Map (August 2015 to August 2020)**  
 Source: [USGS WaterWatch](#)

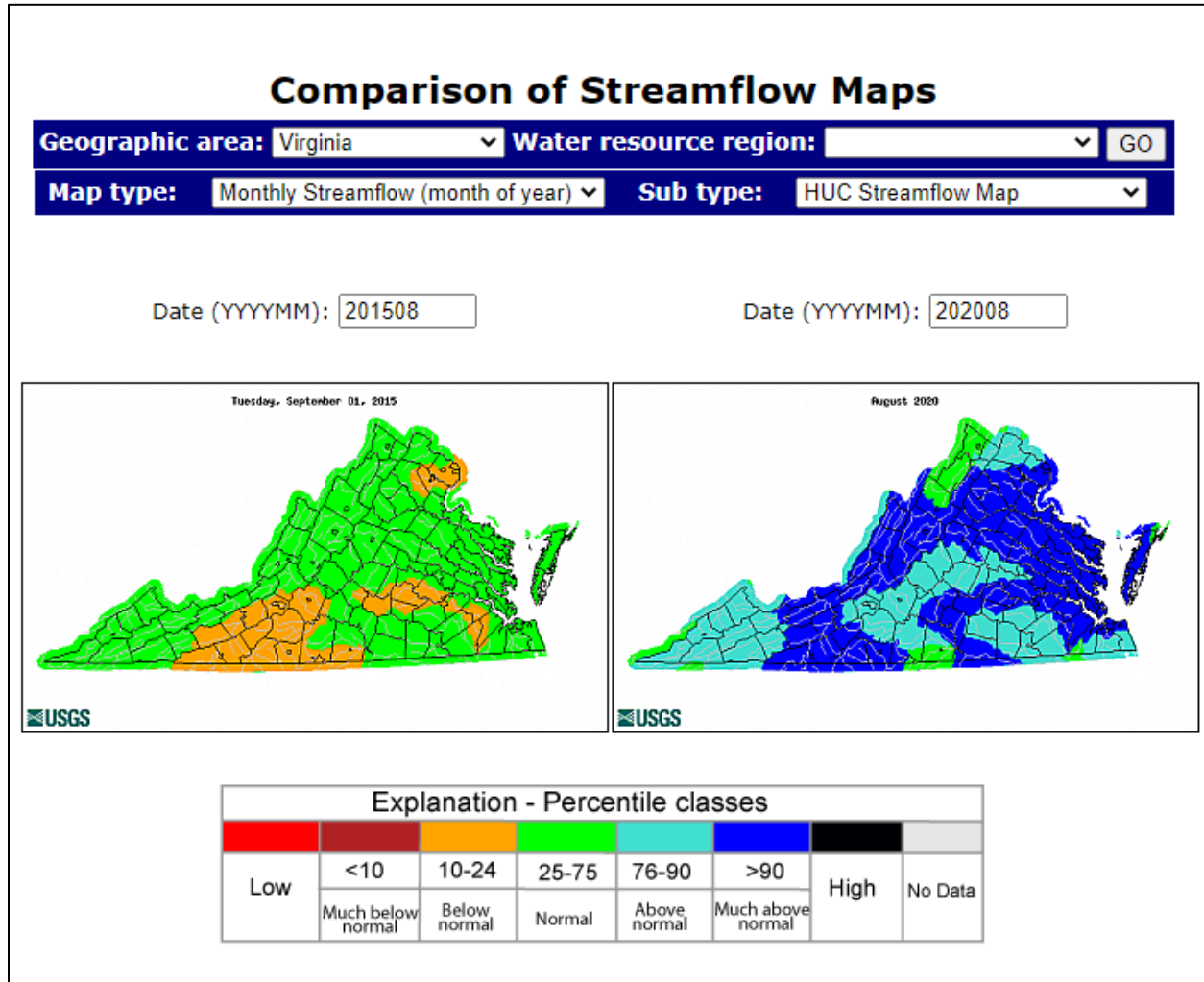

3  
4

Loss Estimates

The Governor's Climate Commission indicated that Virginia is "moving towards more widespread impacts under the driest conditions." Droughts can cause widespread and expensive damages across the entire District or Commonwealth, impacting many economic and ecological sectors. In Virginia, widespread drought can impact livestock, crops, agricultural lands, and over 808,000 acres of freshwater wetlands. Negative impacts from drought conditions will have rippling effects across the District due to the complex web of sectors that contribute to the production of goods and services. Reduced agricultural sector production can lead to higher prices for food, energy, and other essential products. Reduced income for farmers can lead to increased credit risk for financial institutions and lost revenue for local and state governments. Due to these complex relationships, it is difficult to accurately estimate financial damages from a prolonged drought event. Most likely, total damages from serious drought events would fall somewhere in the range of hundreds of thousands of dollars. Because water is non-replaceable as an essential resource for most organisms and many sectors of the economy, losses due to water shortage caused by drought are likely to be repetitive.





1 Vulnerability & Community Development Analysis

2 Communities with significant agricultural operations are most at risk of short-term droughts and  
3 rainfall or snow shortages. Dry periods, and the associated evapotranspiration, can lead to loss  
4 of moisture in soil and impact vegetation and crops.

5 The National Drought Mitigation Center's (NDMC) website contains the Drought Impact  
6 Reporter, which compiles and categorizes the impacts of reported droughts. As seen in the  
7 figures below, from 2015 through the beginning of 2020, Lee County had 8 drought reports,  
8 Scott County had 9 drought reports, and Wise County had 7 drought reports. These reports  
9 were classified by the NDMC as impacts because they caused an observable loss or change at  
10 a specific place and time. Recorded drought impacts in the LENOWISCO Planning District have  
11 included agricultural, energy, fire, plants and wildlife, relief, response and restrictions, and water  
12 supply and quality.

13 **FIGURE: Droughts Impacts in Lee County, 2015-2020**

14 **Source:** <https://droughtreporter.unl.edu/map/>

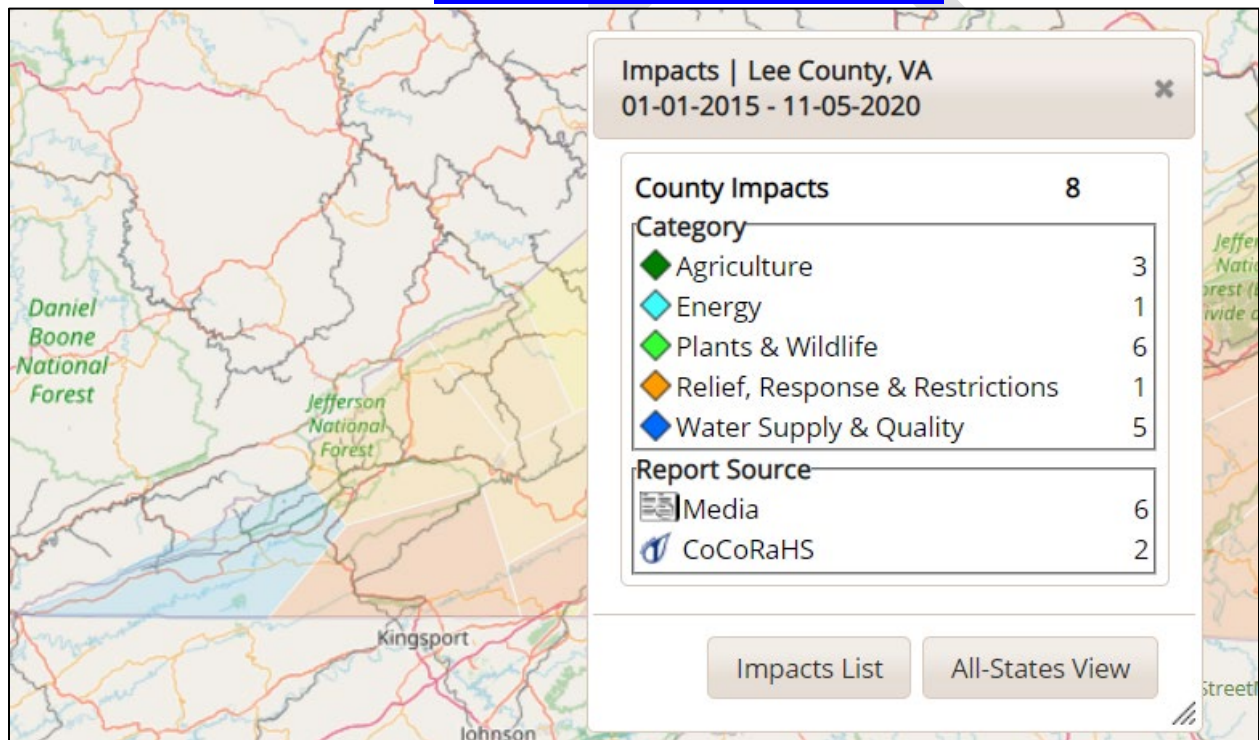

15

16



1  
2

**FIGURE: Droughts Impacts in Scott County, 2015-2020**

Source: <https://droughtreporter.unl.edu/map/>

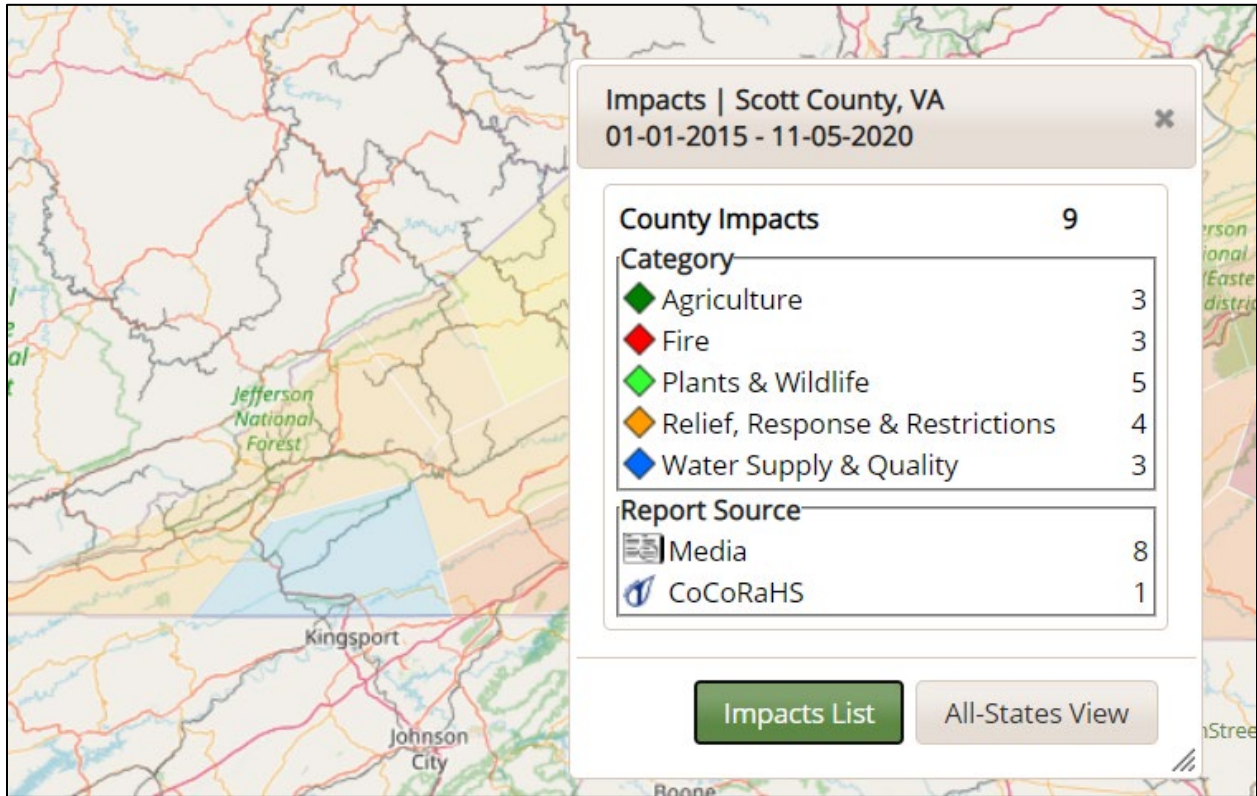

3  
4  
5

**FIGURE: Droughts Impacts in Wise County, 2015-2020**

Source: <https://droughtreporter.unl.edu/map/>

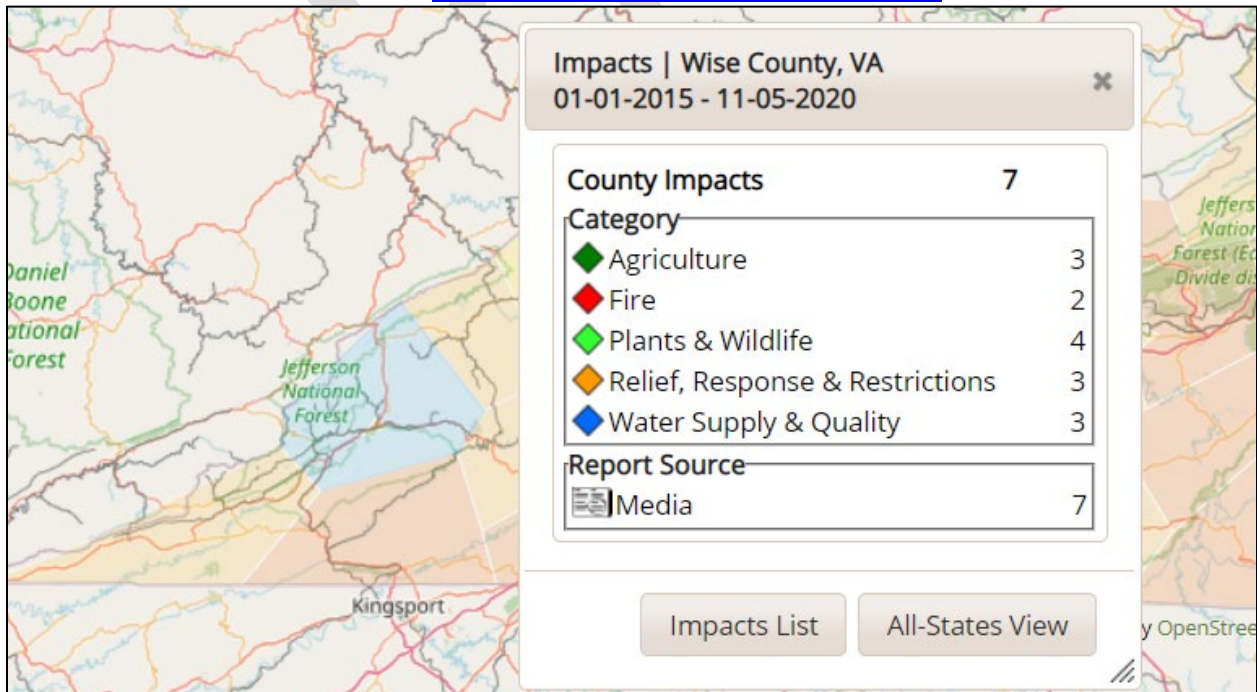

6





1 ***Impact on LENOWISCO Residents***

2 Droughts do not often directly contribute to serious injuries or death, but some secondary  
3 hazards such as extreme heat or wildfire could create health problems or otherwise threaten  
4 residents. There are typically months of warning time leading up to severe drought events.

5 ***Impact on Essential Facilities, Critical Infrastructure, and Future Assets***

6 All essential facilities are vulnerable to minor damages from drought, as they will encounter  
7 many of the same impacts as any other building within the jurisdiction. These impacts include  
8 water shortages, fires as a result of drought conditions, and inhabitants in need of medical care  
9 from the heat and dry weather. No structural damage to existing building stock is expected due  
10 to drought, however. Critical infrastructure will be minimally impacted by drought, as most  
11 impacts, if any, would be secondary in nature.

12 Severe droughts can create water shortages and lead to water restrictions. They may also  
13 contribute to reduced electricity production from hydroelectric dams. Most impacts on critical  
14 infrastructure are minimal and are related to secondary impacts.

15 ***Impact on the Environment***

16 Droughts can have a significant impact on local hydrology for both humans and animals.  
17 Droughts can reduce water quality when natural bodies of water are less able to dilute  
18 pollutants. Changes in salinity, bacteria, temperature, or pH in the water can affect the aquatic  
19 habitat. Water shortages decrease water supply and subsequently food supplies, working its  
20 way through the food chain and increasing mortality and diseases. Additionally, common  
21 impacts of drought may include diminished crop yield, erosion, wildfires, livestock reduction, and  
22 other ecosystem damages.

23 ***Impact on Operations***

24 Most first responder operations should experience relatively little interruption during a drought  
25 event. Medical facilities may experience an increase in residents in need of medical care from  
26 the heat and dry weather, but this would only be true in extreme cases. Should a severe,  
27 prolonged drought event occur, firefighting efforts in urban or suburban areas may become  
28 more difficult, as using other chemicals or methods instead of water are not always appropriate.

29



1 Hazard Evaluation and Impact/Consequence Assessment

Frequency & Probability <sup>1</sup>	Minimally Vulnerable		
Potential Magnitude and Scale <sup>1</sup>	Minimally Vulnerable		
Physical Vulnerability Hazard Impact <sup>1</sup>	Somewhat Vulnerable		
Social Vulnerability Hazard Impact <sup>1</sup>	Vulnerable		
Community Conditions Hazard Impact <sup>1</sup>	Vulnerable		
Overall Capability and Capacity <sup>2</sup>	Somewhat Capable		
Mitigation <sup>2</sup>	Minimally Capable		
Hazard Consequence & Impact Score <sup>1</sup>	Somewhat Vulnerable		
Overall Risk Rating <sup>3</sup>	Medium		
Legend			
Score	1: Vulnerability Rating	2: Capability and Capacity Rating	3: Overall Risk Rating
0 – 24	Minimally Vulnerable	Minimally Capable	Low
25 – 49	Somewhat Vulnerable	Somewhat Capable	Medium
50 – 74	Vulnerable	Capable	High
75 - 100	Very Vulnerable	Very Capable	Extreme
N/A	Not Applicable/Unknown	Not Applicable/Unknown	Not Applicable/Unknown

2

DRAFT



## 1 1.6.4 Earthquake

2 The [U.S. Geological Survey \(USGS\)](#) defines earthquakes as ground shaking caused by the  
3 sudden release of accumulated strain by an abrupt shift of rock along a fracture in the earth or  
4 by volcanic or magmatic activity, or other sudden stress changes in the earth. Earthquakes  
5 cause both vertical and horizontal ground shaking which varies both in amplitude (the amount of  
6 displacement of the seismic waves) and frequency (the number of seismic waves per unit time),  
7 usually lasting less than 30 seconds. Earthquakes are measured both in terms of their inherent  
8 magnitude and in terms of their local intensity.

9 Virginia is near the center of the North American Plate and as such experiences a lower rate of  
10 seismic activity than plate boundaries. Earthquake activity within a tectonic plate (intraplate  
11 seismicity) can still cause extensive and severe damage. The area where the sudden rupture  
12 takes place is called the focus or hypocenter of the earthquake, which on the surface is called  
13 the earthquake epicenter. Earthquakes in Virginia typically occur between 3-15 miles below the  
14 surface.

15 There are two distinct seismic zones that are of significant relevance to the LENOWISCO  
16 Planning District:

- 17 • **Southern Appalachian Seismic Zone (East Tennessee Seismic Zone):** This zone is  
18 subject to frequent but small earthquakes and is the second most active seismic zone  
19 east of the Rocky Mountains. The zone has not recorded an earthquake greater than a  
20 magnitude 5.0 on the Richter Scale but has the potential to generate an earthquake with  
21 a magnitude of 7.5.
- 22 • **Giles County Seismic Zone:** Residents in this seismic zone have experienced small  
23 earthquakes, as well as infrequent larger events that cause some damage. There have  
24 been several events in the seismic zone that were felt across southwestern Virginia,  
25 typically occurring once every 10-20 years.

26



1 Hazard Extent

2 Both the intensity and magnitude of an earthquake provide measures for severity.

3 **Intensity** is the subjective observation of the effects of ground shaking and can vary based on  
 4 site-specific factors and local geologic features, as well as the distance from the earthquake  
 5 epicenter. Intensity is most commonly expressed using the Modified Mercalli Intensity Scale  
 6 (described in the table below). Mercalli intensity is assigned based on eyewitness accounts.  
 7 More quantitatively, the intensity may be measured in terms of peak ground acceleration (PGA)  
 8 expressed relative to the acceleration of gravity (g) and determined by seismographic  
 9 instruments.

**TABLE: Abbreviated Modified Mercalli Intensity Scale**

Mercalli Intensity	Description
I	Not felt except by a very few under especially favorable conditions.
II	Felt only by a few persons at rest, especially on upper floors of buildings.
III	Felt quite noticeably by persons indoors, especially on upper floors of buildings. Many people do not recognize it as an earthquake. Standing motor cars may rock slightly. Vibrations are similar to the passing of a truck. Duration estimated.
IV	Felt indoors by many, outdoors by few during the day. At night, some awakened. Dishes, windows, doors disturbed; walls make cracking sound. Sensation like heavy truck striking building. Standing motor cars rocked noticeably.
V	Felt by nearly everyone; many awakened. Some dishes, windows are broken. Unstable objects overturned. Pendulum clocks may stop.
VI	Felt by all, many frightened. Some heavy furniture moved; a few instances of fallen plaster. Damage slight.
VII	Damage negligible in buildings of good design and construction; slight to moderate in well-built ordinary structures; considerable damage in poorly built or badly designed structures; some chimneys are broken.
VIII	Damage slight in specially designed structures; considerable damage in ordinary substantial buildings with partial collapse. Damage great in poorly built structures. Fall of chimneys, factory stacks, columns, monuments, walls. Heavy furniture overturned.
IX	Damage considerable in specially designed structures; well-designed frame structures thrown out of plumb. Damage great in substantial buildings, with partial collapse. Buildings shifted off foundations.
X	Some well-built wooden structures destroyed; most masonry and frame structures destroyed with foundations. Rails bent.
XI	Few, if any (masonry) structures remain standing. Bridges destroyed. Rails bent greatly.
XII	Damage total. Lines of sight and level are distorted. Objects are thrown into the air.

10

11



1 **Magnitude** is the amount of seismic energy released at the hypocenter of the earthquake,  
 2 beneath the surface. Magnitude is represented by a single value determined by the earthquake  
 3 waves recorded on instruments. Magnitude may be expressed using the familiar Richter Scale  
 4 or using the moment magnitude scale (MMS) now favored by most technical authorities. Both  
 5 the Richter Scale and the MMS are based on logarithmic formula meaning that a difference of  
 6 one unit on the scales represents about a thirty-fold difference in the amount of energy released  
 7 (and, therefore, potential to do damage). On either scale, significant damage can be expected  
 8 from earthquakes with a magnitude of about 5.0 or higher. The table below compares an  
 9 earthquake's magnitude with its relative intensity, as measured by the Modified Mercalli Scale.

TABLE: Earthquake Magnitude vs. Modified Mercalli Intensity Scale	
Earthquake Magnitude	Typical Maximum Modified Mercalli Intensity
1.0-3.0	I
3.0-3.9	II-III
4.0-4.9	IV-V
5.0-5.9	VI-VII
6.0-6.9	VII-IX
7.0 and higher	VIII or higher

10

11 The figure below illustrates the magnitude and associated release of energy for earthquake  
 12 events based on frequency. Most earthquake events, including those in southwestern Virginia,  
 13 are low magnitude, only periodically noticeable to humans.

14

**FIGURE: Earthquake Magnitude and Energy Release**

Source: [U.S. Geological Survey](https://www.usgs.gov/monitoring-data/earthquakes-hazards/earthquake-magnitude-and-energy-release)

15

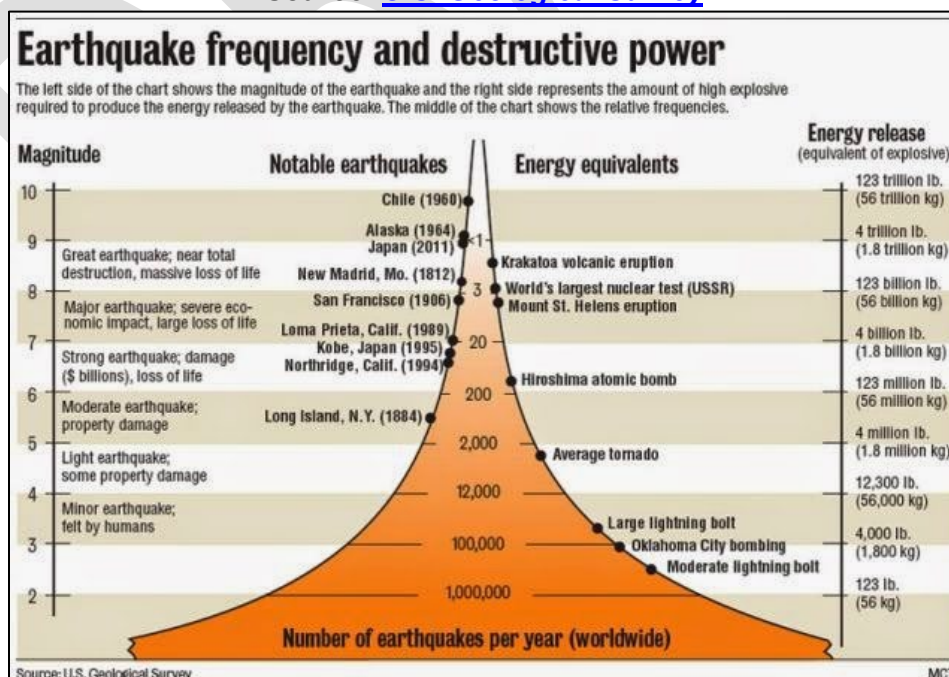

16





1 History/Previous Occurrences

2 There has been one federal disaster declaration for an earthquake in Virginia, in addition to  
3 several recorded historical events. The map below illustrates the locations of known earthquake  
4 epicenters in Virginia, including several in the LENOWISCO Planning District. There has been  
5 no recorded structural damage within the District from an earthquake event.

6 **FIGURE: Earthquake Epicenters in Virginia**  
7 **Source: Virginia Department of Mines, Minerals, and Energy - Division of Geology and**  
8 **Mineral Resources**

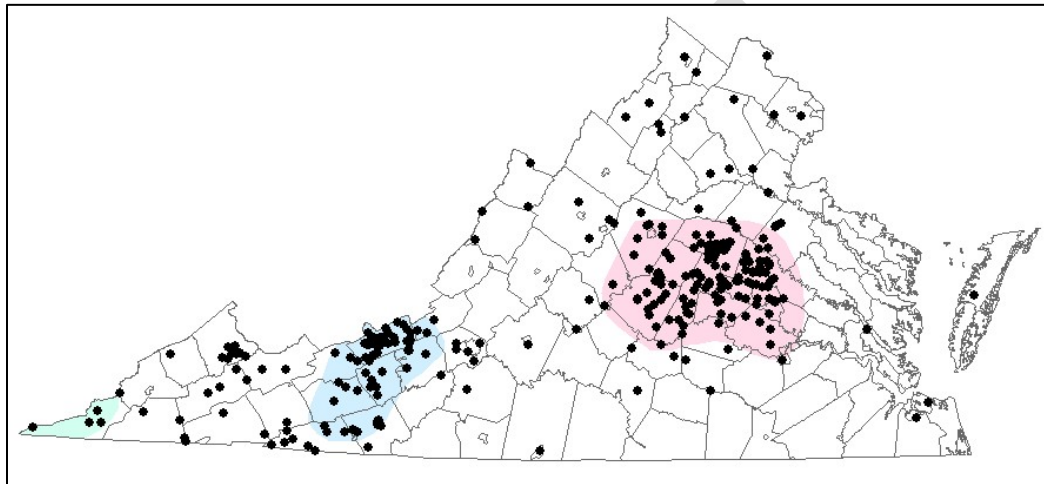

9  
10 As shown in the figure below, there is no record of an earthquake centered in the LENOWISCO  
11 Planning District since 1950 in the USGS record. There are earthquakes that have occurred just  
12 outside of the District, in Kentucky, Tennessee, and other parts of Virginia, that can be felt  
13 inside the District. The map below shows every earthquake in the surrounding areas since 1950  
14 that is greater than 2.5 in magnitude.

15 **FIGURE: Historical Earthquakes near the LENOWISCO Planning District**  
16 **Source: <https://earthquake.usgs.gov/earthquakes/search/>**

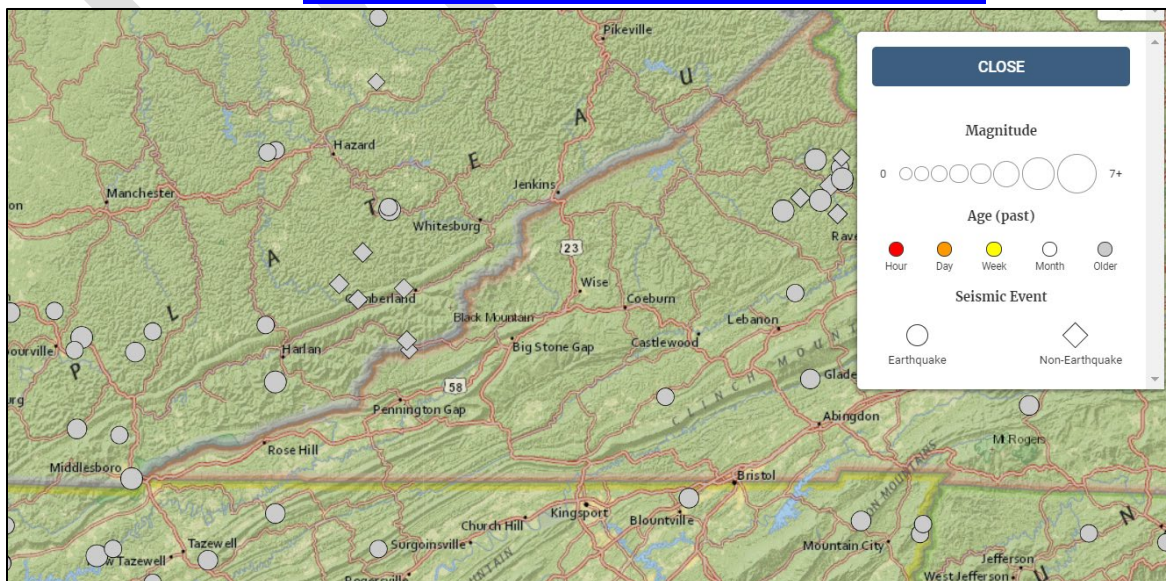



1 Future Probability

2 Based on the Community Vulnerability Risk and Resiliency (CVR2) assessment, detailed in  
3 Section 1.6.13 (methodology) and Section 1.6.14 (results), this hazard is **Minimally**  
4 **Probably/Minimally Frequent**, because this hazard was determined to be extremely rare with  
5 little to no documented history of significant occurrences or events. While it is possible that low  
6 impact events may occur on occasion, the hazard's overall impact on the District and  
7 participating jurisdictions would be very minor. The overall risk ranking for this hazard  
8 is **Medium**. A complete analysis of earthquake probability, using FEMA's HAZUS tool, for the  
9 LENOWISCO Planning District is available at the end of this section.

10 The severity of an earthquake is based on site-specific factors, including distance from the  
11 epicenter, soil type, and more. A moderate magnitude earthquake in either seismic zone of  
12 southwestern Virginia is a low probability event, but one that could cause significant impacts  
13 and disruptions. A moderate earthquake can damage unreinforced buildings, their contents, and  
14 operations. Buildings in low probability earthquake regions are often not designed to withstand a  
15 moderate or significant earthquake event. The map below illustrates the probabilistic ground  
16 motion, assessing the intensity and frequency of seismic events. This potential is expressed as  
17 percent peak ground acceleration (% PGA) over a period of years.

18 **FIGURE: Virginia Seismic Hazard: 2 Percent in 50 Years PGA Hazard**

19 **Source: [2018 Commonwealth of Virginia Hazard Mitigation Plan](#)**

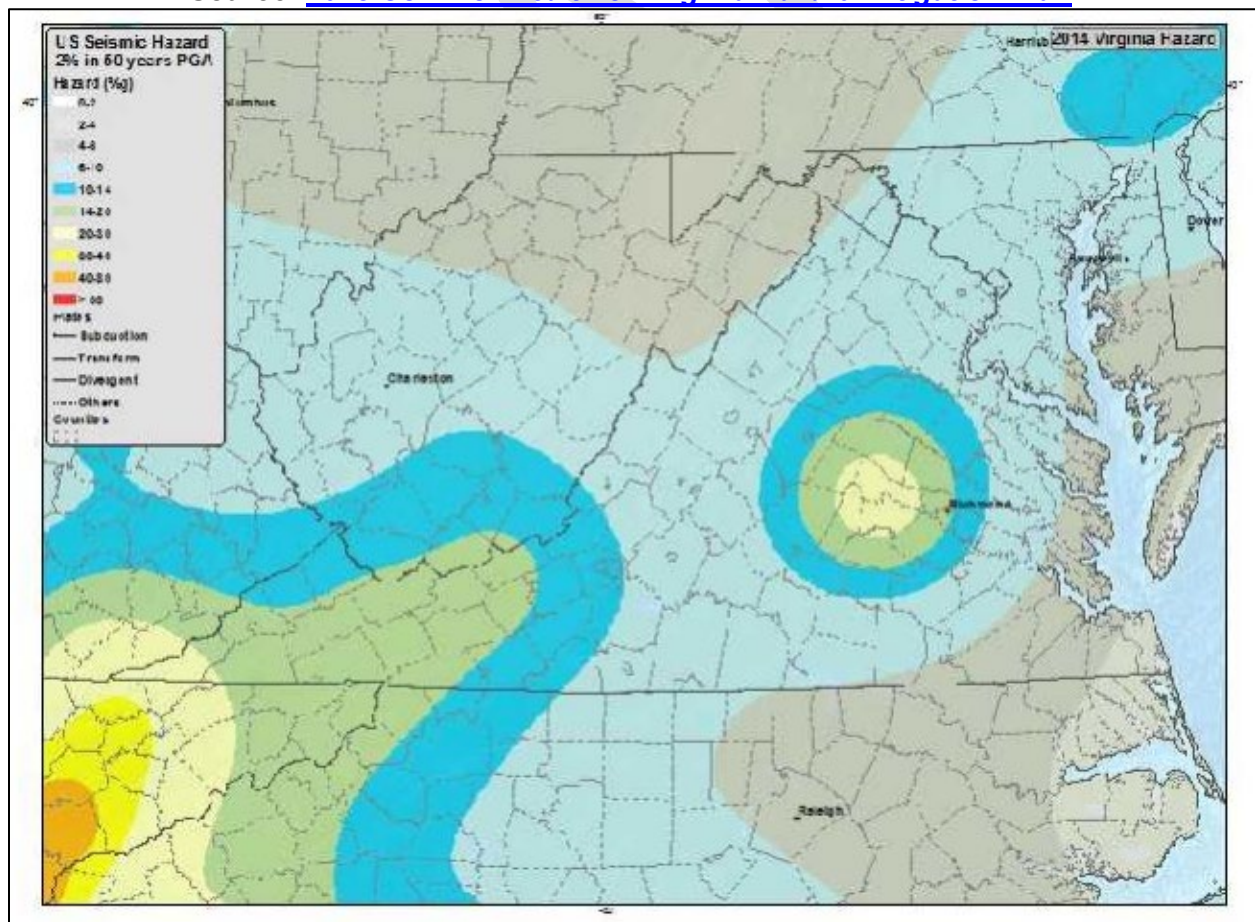

20



- 1 The 2018 Commonwealth of Virginia Hazard Mitigation Plan (HMP) outlines a ranking of each jurisdiction in the LENOWISCO
- 2 Planning District based on various risk factors. The City of Norton is the only jurisdiction in the LENOWISCO Planning District with an
- 3 earthquake risk of "Medium-Low", according to the Commonwealth of Virginia HMP. All other jurisdictions have a "Low" risk ranking.

**TABLE: Earthquake Hazard Ranking Parameters**  
**Source: 2018 Commonwealth of Virginia Hazard Mitigation Plan**

Jurisdiction	Population Vulnerability	Population Density	Injuries & Fatalities	Property Damage	Crop Damage	Events	Geographic Extent	Total Risk Ranking
City of Norton	Low	Medium-High	Low	Low	Low	Medium-Low	Low	Medium-Low
Lee County	Medium	Low	Low	Low	Low	Medium	Low	Low
Scott County	Medium	Low	Low	Low	Low	Medium-Low	Low	Low
Wise County	Medium	Medium	Low	Low	Low	Medium	Low	Low

4





1 Geographic Location

2 An earthquake can impact all jurisdictions within the LENOWISCO Planning District, but some  
3 areas have a higher probability for significant ground shaking due to their proximity to active  
4 seismic zones. The map below shows the main zones in Virginia that are most susceptible to  
5 earthquakes. These zones are believed to be sources of most M>6 earthquakes during the past  
6 1.6 million years around Virginia, though there has never been a quake of that magnitude  
7 recorded in Virginia.

8 **FIGURE: Virginia Earthquake Epicenter Density**  
9 **Source: [2018 Commonwealth of Virginia Hazard Mitigation Plan](#)**

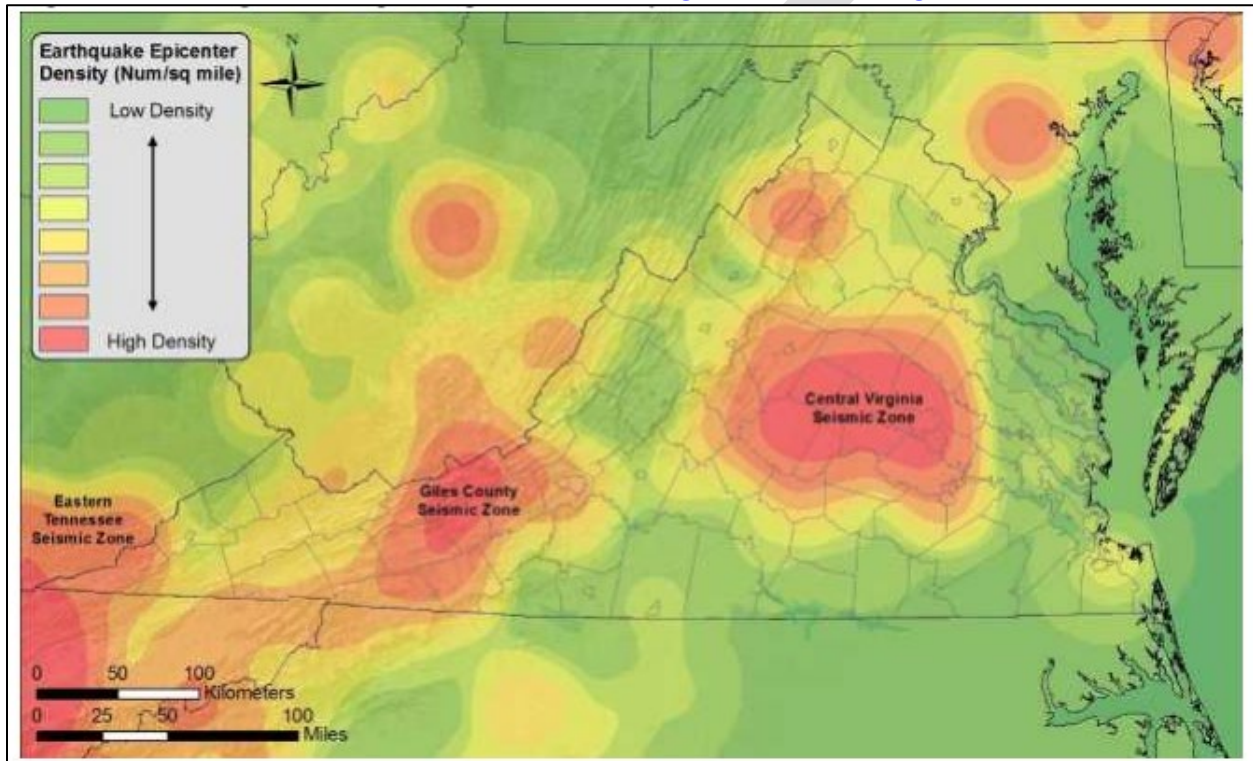

10  
11



1 Lee County is located entirely within the Eastern Tennessee Seismic Zone, with the southern  
 2 portion of Lee County being at the highest risk. Furthermore, the southeastern portion of Scott  
 3 County is located within the Giles County Seismic Zone. As shown in the map below, Lee  
 4 County and southwestern Scott County have some of the highest potentials for ground motion in  
 5 the District, and therefore potential impacts, from an earthquake event. While the areas  
 6 discussed are of particular concern, any seismic event in the region may have impacts  
 7 throughout the District.

8 **Figure: LENOWISCO Planning District Seismic Hazard Risk map based on ground**  
 9 **acceleration g%**

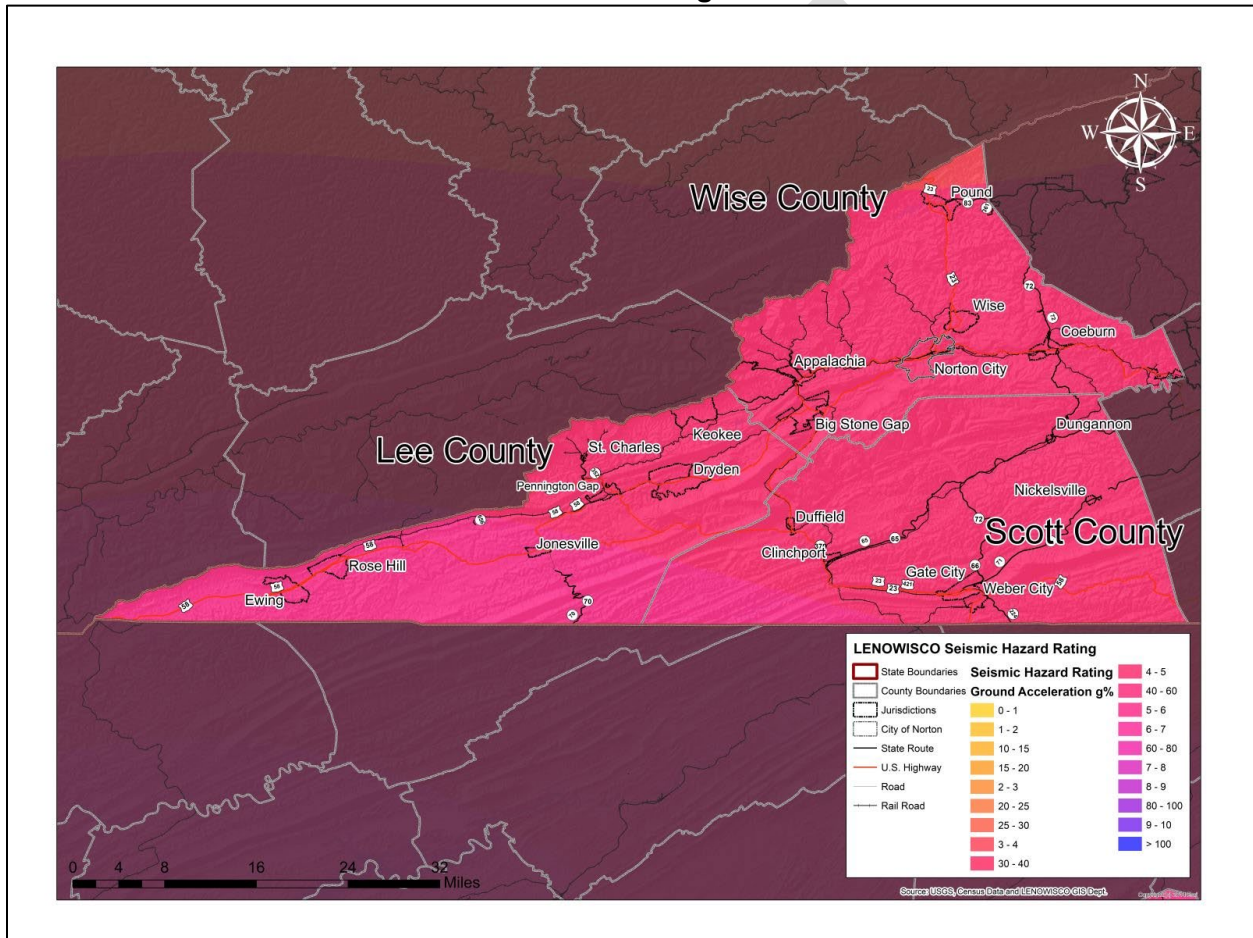

10

11 Loss Estimates

12 Only one major earthquake has been recorded in Virginia in recent history - a 5.8 magnitude  
 13 event in 2011 in Louisa County, located in the Central Virginia Seismic Zone. The event caused  
 14 a reported \$200-300 million dollars in damages and resulted in a Federal Disaster Declaration.  
 15 The 2018 Commonwealth of Virginia HMP includes a detailed HAZUS-MH scenario of the 2011  
 16 event, detailing building and infrastructure damages. The scenario resulted in damages across  
 17 the entire state, with the most significant impacts on residential buildings. Additionally, the  
 18 scenario anticipated significant damages to bridges and school buildings, and moderate  
 19 damage to water, wastewater, and natural gas utility lines.





1 The 2018 Commonwealth of Virginia HMP estimated losses across the region using HAZUS-  
 2 MH based on a 2,500-year event, or a 0.04% annual risk. Such an event would create  
 3 significant economic and structural losses, in addition to social impacts. Given the event details,  
 4 the expected annualized losses for jurisdictions in the LENOWISCO Planning District were low.  
 5 All three counties are expected to see less than \$25,000 in annualized losses, the lowest  
 6 bracket for the State. Estimated losses are included in the table below.

<b>TABLE: 2,500-year Earthquake Scenario Expected Annualized Loss by Jurisdiction</b>	
<b>Source: 2018 Commonwealth of Virginia Hazard Mitigation Plan</b>	
<b>Jurisdiction</b>	<b>Annualized Loss</b>
City of Norton	\$3,280
Lee County	\$11,981
Scott County	\$12,506
Wise County	\$19,669

7  
 8 Using a region-specific HAZUS earthquake probability analysis for a magnitude 5.0 event  
 9 impacting the LENOWISCO Planning District, the total economic loss estimated for the  
 10 earthquake is \$1,610,000, which includes building and lifeline related losses based on the  
 11 region's available inventory. At the end of this section is more detailed information about these  
 12 losses, which can be broadly grouped into three categories: business interruption, and  
 13 transportation and utility lifeline losses.

14 Vulnerability and Community Development Analysis

15 An earthquake with a magnitude of 5.0 or greater poses potential impacts. Fatalities, injuries,  
 16 and significant property damage are all possible vulnerabilities. Earthquakes can also trigger  
 17 other events, such as landslides, dam failures, and subsequent flooding, and more. Historically,  
 18 Virginia's recorded earthquakes have been magnitude 4.5 or less with minor damage such as  
 19 cracks in foundations and falling chimneys (DMME). If Virginia experienced a larger magnitude  
 20 event, at 6.0 or greater, it could lead to the collapse of bridges or tall buildings, damaged  
 21 reservoirs and subsequent flash flooding, electrical fires, or damaged pipelines and waterlines.

22 The following sections include estimated impacts using a HAZUS earthquake probability  
 23 analysis for a magnitude 5.0 event impacting the entire LENOWISCO Planning District.

24 *Impact on LENOWISCO Residents*

25 Residents who live or work in buildings that are not designed to withstand moderate to severe  
 26 shaking from an earthquake event would be most at risk. Poorly built facilities will suffer  
 27 structural damages at much lower levels of shaking than otherwise. Residents would be  
 28 impacted by damaged or collapsed buildings, disrupted power and utilities, limited or restricted  
 29 transportation, and the potential unavailability of first responders.

30 Economic losses for residents and businesses stem from the destruction of structures and  
 31 infrastructure, interruption of business activity, and more. A severe earthquake event would  
 32 contribute to widespread and significant losses. On the other hand, mild earthquakes cause little  
 33 to no business disruption.

34



1 **Casualties**

2 HAZUS estimates the number of people that will be injured and killed by a magnitude 5  
 3 earthquake. The casualties are broken down into four (4) severity levels that describe the extent  
 4 of the injuries. The levels are described as follows;

- 5 • Severity Level 1: Injuries will require medical attention but hospitalization is not needed.
- 6 • Severity Level 2: Injuries will require hospitalization but are not considered life-  
 7 threatening
- 8 • Severity Level 3: Injuries will require hospitalization and can be life-threatening if not  
 9 promptly treated.
- 10 • Severity Level 4: Victims are killed by the earthquake.

11 The table below provides a summary of the casualties estimated for this earthquake. The  
 12 casualty estimates are provided for three (3) times of day: 2:00 AM, 2:00 PM, and 5:00 PM.  
 13 These times represent the periods of the day that different sectors of the community are at their  
 14 peak occupancy loads. The 2:00 AM estimate considers that the residential occupancy load is  
 15 maximum, the 2:00 PM estimate considers that the educational, commercial, and industrial  
 16 sector loads are maximum and 5:00 PM represents peak commute time.

<b>TABLE: LENOWISCO Planning District Earthquake Casualty Estimates</b>					
<i>Source: HAZUS</i>					
<b>Scenario Details</b>		<b>Level 1</b>	<b>Level 2</b>	<b>Level 3</b>	<b>Level 4</b>
2 AM	Commercial	0.00	0.00	0.00	0.00
	Commuting	0.00	0.00	0.00	0.00
	Educational	0.00	0.00	0.00	0.00
	Hotels	0.00	0.00	0.00	0.00
	Industrial	0.00	0.00	0.00	0.00
	Other-Residential	0.20	0.01	0.00	0.00
	Single-Family	0.40	0.03	0.00	0.00
	Total	0.60	0.04	0.0	0.0
2 PM	Commercial	0.26	0.02	0.00	0.00
	Commuting	0.00	0.00	0.00	0.00
	Educational	0.07	0.00	0.00	0.00
	Hotels	0.00	0.00	0.00	0.00
	Industrial	0.04	0.00	0.00	0.00
	Other-Residential	0.06	0.00	0.00	0.00
	Single-Family	0.12	0.01	0.00	0.00
	Total	0.55	0.02	0.00	0.00
5 PM	Commercial	0.19	0.02	0.00	0.00
	Commuting	0.00	0.00	0.00	0.00
	Educational	0.00	0.00	0.00	0.00
	Hotels	0.00	0.00	0.00	0.00
	Industrial	0.02	0.00	0.00	0.00
	Other-Residential	0.08	0.00	0.00	0.00
	Single-Family	0.15	0.02	0.00	0.00
	Total	0.47	0.04	0.00	0.00



1 ***Impact on Essential Facilities, Critical Infrastructure, and Future Assets***

2 All essential facilities are vulnerable to earthquakes. An essential facility would encounter many  
 3 of the same impacts as any other building within the District. These impacts include structural  
 4 failure and loss of facility functionality (e.g., a damaged police station will no longer be able to  
 5 serve the community). Areas along rivers or other bodies of water are more susceptible to  
 6 liquefaction and land shaking which can cause buildings to tilt or sink into the ground. The  
 7 HAZUS earthquake probability analysis for the District estimates that no essential facilities  
 8 would experience damage of greater than 50% - detailed in the table below.

<b>TABLE: Expected Damage to Essential Facilities</b>				
<b>Source: HAZUS</b>				
<b>Classification</b>	<b>Total</b>	<b># Facilities</b>		
		<b>At Least Moderate Damage &gt; 50%</b>	<b>Complete Damage &gt; 50%</b>	<b>With Functionality &gt; 50% on Day 1</b>
Hospitals	7	0	0	4
Schools	49	0	0	49
EOCs	3	0	0	3
Police Stations	17	0	0	15
Fire Stations	32	0	0	32

9

10 During an earthquake, the impacts on infrastructure could include broken, failed, or impassable  
 11 roadways; broken or failed utility lines (e.g., loss of power or gas to the community); and railway  
 12 failure from broken or impassable railways. Bridges also could fail or become impassable,  
 13 causing traffic risks. It is also possible that power disruptions due to earthquakes could affect  
 14 communication infrastructure.

15 Future development, including buildings and infrastructure, should be designed to withstand the  
 16 impacts of a moderate to significant magnitude earthquake. Any structures not designed to  
 17 seismic standards are at greater risk of collapse or damage.

18 ***Impact on the Environment***

19 In the event of an earthquake, environmental impacts would most likely stem from secondary  
 20 hazards such as hazardous materials spills or broken utility lines. Major earthquakes can cause  
 21 significant land and vegetation deformation, but a mild earthquake will cause minimal  
 22 environmental damage.

23 ***Impact on Operations***

24 A major earthquake event may lead to damaged water and energy lines, leading to a disruption  
 25 in emergency response services. Additionally, road or transportation system damages could  
 26 limit evacuation efforts or the ability of first responders to reach injured persons. A severe event  
 27 would place significant stress on local emergency operations, requiring most police, fire, and  
 28 emergency medical personnel, overwhelming or potentially disabling disaster services. Mild  
 29 earthquakes would have little impact on operations.



1 HAZUS Earthquake Probability Analysis Loss Estimates

2 The tables provide details on estimated losses for the LENOWISCO Planning District based on a HAZUS earthquake probability  
 3 analysis for a magnitude 5.0 event.

4 **Building-Related Losses**

5 The direct building losses are the estimated costs to repair or replace the damage caused to the building and its contents. Business  
 6 interruption losses are the losses associated with the inability to operate a business because of the damage sustained during the  
 7 earthquake. Business interruption losses also include the temporary living expenses for those people displaced from their homes  
 8 because of the earthquake.

9 HAZUS estimates that about 49 buildings will be at least moderately damaged. This is well under 1% of the buildings in the region.  
 10 No buildings are estimated to be damaged beyond repair. The tables below summarize the expected damage and loss. **The total**  
 11 **building-related losses were \$4.73 million. By far, the largest loss was sustained by the residential occupancy category which made**  
 12 **up over 55% of the total loss.**

**TABLE: Expected Building Damage by Occupancy**

Building Occupancy Type	None		Slight		Moderate		Extensive		Complete	
	Count	%	Count	%	Count	%	Count	%	Count	%
Agriculture	62.69	99%	0.23	0%	0.06	0%	0.00	0%	0.00	0%
Commercial	1,265.85	99%	5.62	0%	1.38	0%	0.15	0%	0.00	0%
Education	97.52	99%	0.40	0%	0.09	0%	0.00	0%	0.00	0%
Government	77.54	99%	0.45	0%	0.08	0%	0.00	0%	0.00	0%
Industrial	300.57	99%	1.13	0%	1.62	0%	0.03	0%	0.00	0%
Other Residential	10,095.88	99%	97.07	0%	21.51	0%	0.16	0%	0.00	0%
Religion	173.13	0%	0.67	0%	0.19	0%	0.03	0%	0.00	0%
Single-Family	29,332.05	99%	83.80	0%	21.70	0%	2.33	0%	0.13	0%
Total	41,405.23	99%	189.37	0%	46.63	0%	2.70	0%	0.13	0%

13



**TABLE: Building-Related Economic Loss Estimates (Millions of Dollars)**

Category	Area	Single Family	Other Residential	Commercial	Industrial	Others	Total
Income Losses	Wage	0.0000	0.0148	0.0455	0.0011	0.0084	0.0698
	Capital-Related	0.0000	0.0062	0.0327	0.0006	0.0011	0.0407
	Rental	0.0450	0.0185	0.0278	0.0006	0.0018	0.0937
	Relocation	0.1574	0.0385	0.0356	0.0036	0.0155	0.2506
	Subtotal	0.2024	0.1491	0.1416	0.0059	0.0268	0.4541
Capital Stock Losses							
	Structural	0.2404	0.0698	0.0578	0.0089	0.017	0.3494
	Non-Structural	0.5538	0.0988	0.0414	0.0064	0.0181	0.4416
	Content	0.0236	0.0041	0.0078	0.0027	0.0029	0.0411
	Inventry	0.0000	0.0000	0.0000	0.0005	0.000	0.0000
	Subtotal	1.6356	0.4192	0.1772	0.0986	0.0641	0.8321
<b>Total</b>		<b>2.1448</b>	<b>0.4903</b>	<b>0.3188</b>	<b>0.1046</b>	<b>0.0910</b>	<b>1.5869</b>

1

2





1 **Transportation and Utility Lifeline Losses**

- 2 For the transportation and utility lifeline systems, HAZUS computes the direct repair cost for each component only. There are no
- 3 losses computed by HAZUS for business interruption due to lifeline outages. The losses for the transportation and utility systems are
- 4 displayed separately below.

**TABLE: Expected Damage to the Transportation Systems**

System	Component	Locations/ Segments	With at Least Mod. Damage	Number of Locations		With Functionality > 50 %	
				With Complete Damage	After Day 1	After Day 7	
Highway	Segments	48	0	0	48	48	
	Bridges	320	0	0	444	444	
	Tunnels	0	0	0	0	0	
Railways	Segments	169	0	0	207	207	
	Bridges	211	0	0	211	211	
	Tunnels	0	0	0	0	0	
Light Rail	Facilities	0	0	0	0	0	
	Facilities	0	0	0	0	0	
	Facilities	0	0	0	0	0	
Ferry	Facilities	0	0	0	0	0	
	Facilities	0	0	0	0	0	
Port	Facilities	4	0	0	4	4	
	Runways	2	0	0	2	2	
Airport	Runways	2	0	0	2	2	

5  
6  
7



1

**TABLE: Transportation System Economic Losses (Millions of Dollars)**

System	Component	Inventory Value	Economic Loss	Loss Ratio (%)
Highway	Segments	1,892.0217	0.0000	0.00
	Bridges	753.0123	0.0000	0.00
	Tunnels	0.0000	0.0000	0.00
	<b>Subtotal</b>	<b>2,645.034</b>	<b>0.0000</b>	<b>0.00</b>
Railways	Segments	530.1004	0.0000	0.00
	Bridges	927.2976	0.0000	0.00
	Tunnels	0.0000	0.0000	0.00
	Facilities	0.0000	0.0000	0.00
	<b>Subtotal</b>	<b>1,457.398</b>	<b>0.0000</b>	<b>0.00</b>
Light Rail	Segments	0.0000	0.0000	0.00
	Bridges	0.0000	0.0000	0.00
	Tunnels	0.0000	0.0000	0.00
	Facilities	0.0000	0.0000	0.00
	<b>Subtotal</b>	<b>0.0000</b>	<b>0.0000</b>	<b>0.00</b>
Bus	Facilities	0.0000	0.0000	0.00
	Subtotal	0.0000	0.0000	0.00
	Facilities	0.0000	0.0000	0.00
Ferry	Subtotal	0.0000	0.0000	0.00
	Facilities	0.0000	0.0000	0.00
Port	Subtotal	0.0000	0.0000	0.00
	Facilities	17.5789	0.0466	0.92
Airport	Runways	75.4195	0.0000	0.00
	Subtotal	92.9984	0.0466	0.92
<b>Total (Millions of Dollars)</b>		<b>93.035</b>		<b>0.92</b>

2

3

4



**TABLE: Expected Utility System Facility Damage**

System	# of Locations				
	Total #	With at Least Moderate Damage	With Complete Damage	With Functionality > 50%	
				After Day 1	After Day 7
Potable Water	10	0	0	10	10
Wastewater	46	0	0	46	46
Natural Gas	0	0	0	0	0
Oil Systems	0	0	0	0	0
Electrical Power	1	0	0	1	1
Communication	13	0	0	13	13

1

**TABLE: Expected Utility System Pipeline Damage (Site Specific)**

System	Total Pipelines Length (miles)	Number of Leaks	Number of Breaks
Potable Water	11,138	3	0
Wastewater	6,683	0	0
Natural Gas	2,997	0	0
Oil	0	0	0

2

**TABLE: Expected Potable Water and Electric Power System Performance**

	Total # of Households	Number of Households without Service				
		At Day 1	At Day 3	At Day 7	At Day 30	At Day 90
Potable Water	35,902	0	0	0	0	0
Electric Power		0	0	0	0	0

3

4



1

<b>TABLE: Utility System Economic Losses (Millions of Dollars)</b>				
<b>System</b>	<b>Component</b>	<b>Inventory Value</b>	<b>Economic Loss</b>	<b>Loss Ratio (%)</b>
Potable Water	Pipelines	0.00000	0.0000	0.00
	Facilities	309.69	0.0112	0.00
	Distribution Lines	358.5103	0.0091	0.00
	<b>Subtotal</b>	<b>668.2003</b>	<b>0.0203</b>	<b>0.00</b>
Wastewater	Pipelines	0.0000	0.0000	0.00
	Facilities	4,524.8613	0.2338	0.00
	Distribution Lines	215.1062	0.0045	0.00
	<b>Subtotal</b>	<b>9,479.407</b>	<b>0.2383</b>	<b>0.00</b>
Natural Gas	Pipelines	0.0000	0.0000	0.00
	Facilities	0.0000	0.1659	0.00
	Distribution Lines	143.4041	0.0025	0.00
	<b>Subtotal</b>	<b>143.4041</b>	<b>0.1684</b>	<b>0.00</b>
Oil Systems	Pipelines	0.0000	0.0000	0.00
	Facilities	0.0000	0.0000	0.00
	<b>Subtotal</b>	<b>0.0000</b>	<b>0.0000</b>	<b>0.00</b>
Electrical Power	Facilities	796.0858	0.0115	0.00
	<b>Subtotal</b>	<b>796.0858</b>	<b>0.0115</b>	<b>0.00</b>
	Facilities	1.209	0.0000	0.00
Communication	<b>Subtotal</b>	<b>1.209</b>	<b>0.0000</b>	<b>0.00</b>
	<b>Total (Millions of Dollars)</b>	<b>11,084.3062</b>	<b>0.4385</b>	<b>0.00</b>

2

3



1 Hazard Evaluation and Impact/Consequence Assessment

Frequency & Probability <sup>1</sup>	Minimally Vulnerable		
Potential Magnitude and Scale <sup>1</sup>	Minimally Vulnerable		
Physical Vulnerability Hazard Impact <sup>1</sup>	Vulnerable		
Social Vulnerability Hazard Impact <sup>1</sup>	Vulnerable		
Community Conditions Hazard Impact <sup>1</sup>	Vulnerable		
Overall Capability and Capacity <sup>2</sup>	Somewhat Capable		
Mitigation <sup>2</sup>	Minimally Capable		
Hazard Consequence & Impact Score <sup>1</sup>	Vulnerable		
Overall Risk Rating <sup>3</sup>	Medium		
Legend			
Score	1: Vulnerability Rating	2: Capability and Capacity Rating	3: Overall Risk Rating
0 – 24	Minimally Vulnerable	Minimally Capable	Low
25 – 49	Somewhat Vulnerable	Somewhat Capable	Medium
50 – 74	Vulnerable	Capable	High
75 - 100	Very Vulnerable	Very Capable	Extreme
N/A	Not Applicable/Unknown	Not Applicable/Unknown	Not Applicable/Unknown

2

DRAFT





## 1 1.6.5 Flooding

2 Flooding is defined by the National Weather Service (NWS) as the inundation of normally dry  
3 areas because of increased water levels in an established watercourse. Two types of flooding  
4 events are included in this plan:

- 5 • **Riverine or Stream Flooding:** Riverine flooding occurs when a channel receives more  
6 water than it can hold, and the excess water flows over its banks and inundates low-lying  
7 areas, causing a flood (FEMA 2007). Riverine flooding can occur due to rapid snowmelt  
8 or prolonged or heavy rainfall, which is also a cause of flash flooding.
- 9 • **Flash Flooding:** Flash floods result from a large amount of rain in a short period of time,  
10 typically within six hours of an event (NWS 2009). This type of event is particularly  
11 hazardous in mountainous areas or other places with restricted floodplain storage. More  
12 urbanized areas may see flash flooding due to a lack of permeable surfaces.

13 Flooding can be natural, human-caused, or a combination of both. Human-caused flooding  
14 includes dam failure, levee failure, and activities that increase the rate and amount of runoff,  
15 such as paving, reducing ground cover, and clearing forested areas. The amount of damage  
16 caused by a flood is influenced by the speed and volume of the water flow, the length of time  
17 the impacted area is inundated, the amount of sediment and debris carried and deposited, and  
18 the amount of erosion that may take place.

19 Flooding is a dynamic natural process. Along rivers, streams, and coastal bluffs, a cycle of  
20 erosion and deposition is continuously rearranging and rejuvenating the aquatic and terrestrial  
21 systems. Although many plants, animals, and insects have evolved to accommodate and take  
22 advantage of these ever-changing environments, property and infrastructure damage often  
23 occurs when people develop coastal areas and floodplains, and natural processes are altered or  
24 ignored.

25 Flooding can also threaten life, safety, and health and often results in substantial damage to  
26 infrastructure, homes, and other property. The extent of damage caused by a flood depends on  
27 the topography, soils, and vegetation in an area, the depth and duration of flooding, velocity of  
28 flow, rate of rising, and the amount and type of development in the floodplain.

### 29 *Flood Terminology*

30 Several flood-related terms are frequently used in this plan and are defined below.

- 31 • **Flood Insurance Study (FIS):** A Flood Insurance Study is the official report provided by  
32 the Federal Insurance Administration, which provides flood profiles, the flood boundary-  
33 floodway map, and the water surface elevation of the estimated 100-year base flood.
- 34 • **Flood Insurance Rate Map (FIRM):** The Flood Insurance Rate Maps (FIRM) are the  
35 official maps on which the Federal Insurance Administration has delineated both the  
36 areas of special flood hazards and the risk premium zones applicable to the community.
- 37 • **100-year Base Flood:** Base Flood means a flood having a 1% chance of being equaled  
38 or exceeded in any given year. Also referred to as the 100-year flood. Since the 100-  
39 year flood level is statistically computed using existing data, as more data comes in, the  
40 level of the 100-year flood will change. As more data are collected, or when a river basin  
41 is altered in a way that affects the flow of water in the river, re-evaluation is needed.



- 1 Alterations can include dams and urban development, and other human-made changes  
2 in a basin that affect floods (USGS).
- 3 • **500-year Flood:** a flood that has a 0.2% of being equaled or exceeded each year. The  
4 nomenclature can be confusing and does not mean this flood will only happen every 500  
5 years. This type of flood has at least a 6% of occurring in a 30-year time period with the  
6 100-year flood.
  - 7 • **Floodplain:** A floodplain is an area adjacent to a lake, river, stream, estuary, or another  
8 water body that is subject to flooding. If left undisturbed, the floodplain serves to store  
9 and discharge excess floodwater. In riverine systems, the floodplain includes the  
10 floodway.
  - 11 • **Floodway:** Floodway means the channel of a river or other watercourse and the  
12 adjacent areas that must be reserved in order to discharge the base flood without  
13 cumulatively increasing the water surface elevation more than one foot.

#### 14 *Flooding in Virginia*

15 According to the 2018 Commonwealth of Virginia Hazard Mitigation Plan, 38 of the 64 federal  
16 disaster declarations in the state between 1957 and 2016 included flooding impacts. Flooding is  
17 one of the most common hazards in Virginia, and the western parts of the state are most at risk  
18 of riverine flooding and occasional flash flooding. Flooding can occur at any time of the year in  
19 Virginia, but heavy rains from hurricanes, tropical systems, and seasonal rain patterns are most  
20 common in the spring, summer, and fall.

21 The Virginia Department of Emergency Management operates the Integrated Flood Observation  
22 and Warning System (IFLOWS) network consisting of 279 rain gauges and 72 stream gauges  
23 located primarily along the I-81 corridor in western Virginia. The gauges collect and report data  
24 in real-time to local, state, and federal agencies. The National Weather Service relies on the  
25 system to issue updates and warnings of potential flooding hazards.

#### 26 *Flooding in the LENOWISCO Planning District*

27 Flooding is the most significant and frequent natural hazard in the LENOWISCO Planning  
28 District, especially flash flooding after a period of intense or sustained rainfall. The District is a  
29 mountainous region with steep ridges and pronounced valleys, with three major water basins –  
30 the Clinch, Powell, and Holston river basins. A number of streams and tributaries are located  
31 within these basins. The Pound River and other smaller tributaries located in the northeastern  
32 portion of the district drain into the Levisa Fork of the Big Sandy River.

33 The highly mountainous terrain and associated steep slopes cause rainwater to run off rapidly,  
34 quickly filling streambeds. Flood-producing storms can occur throughout the year; historically,  
35 however, the most common months for significant flooding are January, February, and March.  
36 These months, along with April and December, have the highest average precipitation and the  
37 highest frequency of intense rainfall events. In addition, flood events can be exacerbated by  
38 rapidly melting snow during the winter months.

39



1  
2

**FIGURE: Commonwealth of Virginia Watersheds**  
**Source: Virginia Department of Conservation and Recreation**

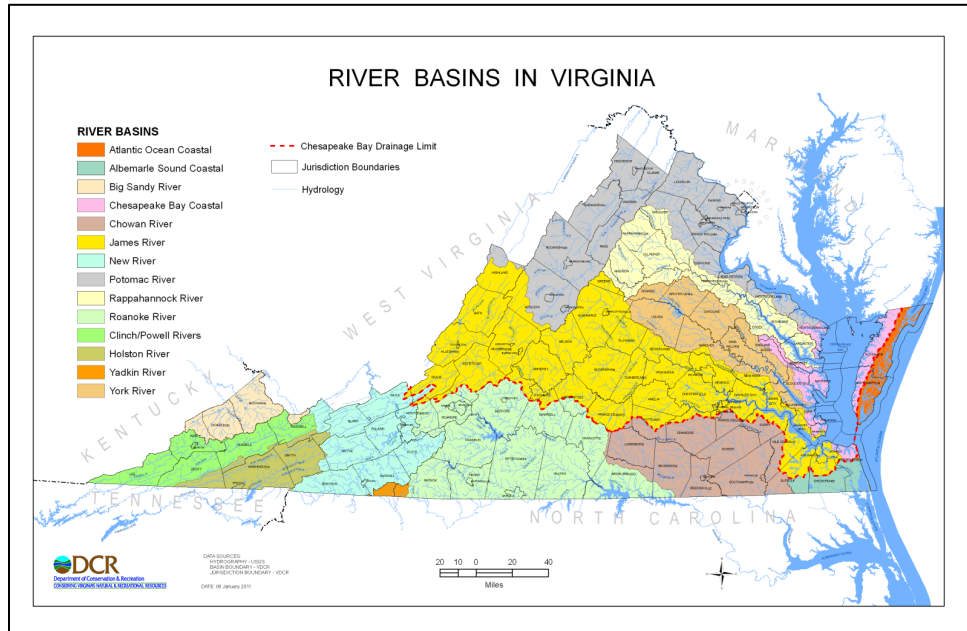

3

#### 4 Hazard Extent

5 Under the National Flood Insurance Plan (NFIP), the Federal standard for floodplain  
6 management is the 100-year floodplain. This area is chosen using historical data such that in  
7 any given year, there is a 1% chance of a Base Flood (also known as 100-year Flood or  
8 Regulatory Flood). Flood Insurance Rate Maps (FIRMs) identify flood zones through detailed  
9 hydrologic and hydraulic studies. These zones represent the areas susceptible to the 1% annual  
10 chance flood, or 100-year flood. Where possible, FEMA also determines a Base Flood Elevation  
11 (BFE) for the 100-year floodplain, which is the calculated elevation of flooding during this event  
12 and a commonly used standard for determining flood risk and managing potential floodplain  
13 development. These maps provide a more definitive representation of the highest flood risks in  
14 the communities. All jurisdictions in Virginia now have digitized FIRMs, available online through  
15 the [Virginia Flood Risk Information System \(VFRIS\)](#).

#### 16 NFIP Participation

17 All jurisdictions in the LENOWISCO Planning District participate in NFIP. The district has no  
18 communities within the 100-year flood plain hazard areas that are not participating in the NFIP  
19 and no communities under suspension or revocation of participation in the NFIP.

20 Currently, no jurisdiction in the LENOWISCO Planning District participates in the Community  
21 Rating System (CRS). To encourage communities to go beyond the minimum requirements and  
22 further prevent and protect against flood damage, the NFIP established the CRS. To qualify for  
23 CRS, communities can do things like make building codes more rigorous, maintain drainage  
24 systems, and inform residents of flood risk. In exchange for becoming more flood ready, the  
25 CRS community's residents are offered discounted premium rates. Based on the community's  
26 CRS ratings, they can qualify for up to a 45% discount on annual flood insurance premiums  
27 ([FEMA, 2020](#)).



1 History/Previous Occurrences

- 2 During the analysis timeframe (2015-2020) for the HMP update, 12 events were recorded in the NOAA National Centers for  
 3 Environmental Information (NCEI) Database. The majority of the events impacted multiple areas in the LENOWISCO Planning  
 4 District. For the reported events, property damage totaled \$225,500.

**TABLE: Flood and Flash Flood Events in LENOWISCO from 01/01/2015 to 10/01/2020**

Source: [www.ncdc.noaa.gov/stormevents](http://www.ncdc.noaa.gov/stormevents)

Jurisdiction	Event Type	Dates of Occurrence	Direct Deaths	Direct Injuries	Reported Property Damage	Reported Crop Damage	Indirect Deaths	Indirect Injuries
City of Norton	Flood	3/4/2015	0	0	\$8,000	\$0	0	0
	Flood	3/5/2015	0	0	\$30,000	\$0	0	0
	Flood	2/10/2018	0	0	\$5,000	\$0	0	0
	Flash Flood	8/8/2016	0	0	\$3,000	\$0	0	0
Lee County	Flood	3/4/2015	0	0	\$500	\$0	0	0
	Flood	2/10/2018	0	0	\$0	\$0	0	0
	Flood	2/6/2020	0	0	\$0	\$0	0	0
Scott County	Flood	3/5/2015	0	0	\$1,000	\$0	0	0
	Flood	4/23/2017	0	0	\$1,000	\$0	0	0
	Flood	2/10/2018	0	0	\$0	\$0	0	0
	Flash Flood	5/27/2017	0	0	\$1,000	\$0	0	0
	Flood	4/19/2019	0	0	\$0	\$0	0	0
Wise County	Flood	3/4/2015	0	0	\$20,000	\$0	0	0
	Flood	4/22/2017	0	0	\$0	\$0	0	0
	Flood	2/10/2018	0	0	\$7,000	\$0	0	0
	Flood	2/6/2020	0	0	\$196,000	\$0	0	0
	Flash Flood	7/27/2016	0	0	\$6,000	\$0	0	0
	Flood	5/26/2018	0	0	\$0	\$0	0	0
	Flood	6/26/2018	0	0	\$0	\$0	0	0



1 **Event Details**

- 2 • **March 4-5, 2015:** An unusually deep snowpack across southwest Virginia underwent  
3 melting from warming temperatures and from liquid rain falling upon it. Flooding in low-  
4 lying areas, streams, and rivers resulted and became widespread. Flooding closed  
5 numerous roads across all three counties in the District. Some homes and structures  
6 reported flooding in the City of Norton and Wise County. One mobile home was  
7 destroyed in the City of Norton due to a mudslide, but no injuries were reported. Across  
8 the LENOWISCO Planning District, this flooding event caused a reported \$59,500 in  
9 property damages.
- 10 • **July 27, 2016:** Wise County experienced flash flooding from summer convection. Water  
11 entered several homes and covered several roadways, causing a reported \$6,000 in  
12 property damage.
- 13 • **August 8, 2016:** The City of Norton experienced flash flooding due to summer  
14 thunderstorms, resulting in several flooded roadways and affected businesses. The  
15 event caused a reported \$3,000 in property damage.
- 16 • **April 22-23, 2017:** Scott and Wise counties experienced heavy rain leading to some  
17 flooding near Banner and Gate City, resulting in road closures and a reported \$1,000 in  
18 property damage.
- 19 • **May 27, 2017:** A summer storm event causes flooding in northern Scott County,  
20 resulting in high water across roadways and a reported \$1,000 in property damage.
- 21 • **February 10, 2018:** A weather front brought unseasonably warm and humid conditions  
22 to the entirety of southwest Virginia, resulting in heavy rains across the District.  
23 Subsequent flooding led to multiple road closures across all three counties, as well as  
24 mudslides in Wise County. Some residents were evacuated in Big Stone Gap, and there  
25 was one water rescue in Powell Valley, with no injuries. The event resulted in a reported  
26 \$12,000 in property damage across the District.
- 27 • **May 26, 2018:** Isolated flooding in Wise County with some road closures but no reported  
28 property damage.
- 29 • **June 26, 2018:** Isolated flooding in Wise County with some road closures but no  
30 reported property damage.
- 31 • **April 19, 2019:** Isolated flooding in Scott County with some road closures but no  
32 reported property damage.
- 33 • **February 6, 2020:** A low-pressure system causes heavy rainfall of 5-6" across both Lee  
34 and Wise counties. Flooding closed several roadways and highways, with the most  
35 significant damage near Big Stone Gap causing a reported \$196,000 in property  
36 damage.
- 37 • A more detailed spreadsheet of recent events can be accessed through [this link](#).

38 Additional flood history and data are organized by watershed. All counties in the LENOWISCO  
39 Planning District have portions in multiple watersheds.

40





1 **Clinch River Basin**

2 The flood stage for the Clinch River Basin near Speers Ferry in Scott County is 18 feet, which  
 3 has been exceeded 61 times according to NWS Advanced Hydrologic Prediction Service  
 4 records, including seven events during the HMP analysis period (2015-2020). Three recorded  
 5 events have exceeded the major flood stage threshold of 32 feet, with a record-high crest of  
 6 nearly 37 feet in April 1977. The most significant flooding event during the HMP analysis period  
 7 was on April 7, 2020, with a crest of 28.52 feet, and on March 5, 2015, with a crest of about 28  
 8 feet. Both events exceeded the moderate flood stage threshold. The table below includes the  
 9 top 30 events on the Powell River.

<b>TABLE: Historic Crest Heights on the Clinch River</b> <i>Source: NWS Advanced Hydrologic Prediction Service</i>		
Flood Category	Crest Height	Date
Major Flood Stage (32 ft)	36.69 ft	4/5/1977
	33.0 ft	2/1/1962
	32.3 ft	3/19/2002
Moderate Flood Stage (28 ft)	29.93 ft	3/12/1963
	28.92 ft	1/30/1957
	28.52 ft	3/7/2020
	28.19 ft	3/17/1973
	28.10 ft	3/5/2015
Flood Stage (18 ft)	27.60 ft	2/28/1902
	27.43 ft	12/31/1969
	27.23 ft	1/26/1978
	27.0 ft	2/11/1994
	26.80 ft	2/11/2018
	26.64 ft	2/24/2019
	26.54 ft	5/7/1984
	25.85 ft	2/3/1923
	25.60 ft	4/24/2017
	25.19 ft	3/30/1975
	24.70 ft	12/22/1926
	24.50 ft	2/17/2003
	24.43 ft	3/7/1967
	24.20 ft	4/17/1998
	23.95 ft	5/7/1958
	23.61 ft	5/8/1971
	23.60 ft	12/11/1972
	23.50 ft	1/8/1946
	23.32 ft	4/13/2020
	23.16 ft	2/18/1944
	23.10 ft	1/30/1932
23.10 ft	2/2/1950	

10

11



1 **Powell River Basin**

2 The flood stage on the Powell River Basin at Jonesville is 18 feet, which has been exceeded 53  
 3 times according to NWS Advanced Hydrologic Prediction Service records. During the HMP  
 4 analysis period (2015-2020), there have been six events exceeding the flood stage. Moderate  
 5 flood stage is 30 feet, which has been exceeded seven times, with no events during the HMP  
 6 analysis period. The table below includes the top 30 events on the Powell River.

<b>TABLE: Historic Crest Heights on the Powell River</b>		
<b>Source: <u>NWS Advanced Hydrologic Prediction Service</u></b>		
<b>Flood Category</b>	<b>Crest Height</b>	<b>Date</b>
Major Flood Stage (35 ft)	44.32 ft	4/5/1977
	33.36 ft	3/12/1963
Moderate Flood Stage (30 ft)	33 ft	1/18/1918
	32.4 ft	3/18/2002
	32.16 ft	12/31/1969
	30.8 ft	1/8/1946
	30.12 ft	2/16/2003
	29.3 ft	2/11/2018
	29.03 ft	3/7/1967
Flood Stage (18 ft)	27.19 ft	2/6/2020
	26.78 ft	1/30/1957
	26.75 ft	3/17/1973
	26.59 ft	2/11/1994
	26.2 ft	3/5/2015
	25.85 ft	2/14/1948
	25.64 ft	1/30/1932
	25.64 ft	2/18/1944
	25.59 ft	5/7/1984
	24.28 ft	2/3/1939
	24.04 ft	1/11/1974
	23.73 ft	3/6/1963
	23.62 ft	12/10/1971
	23.53 ft	4/16/1956
	22.75 ft	4/28/1970
	22.59 ft	2/3/1937
	22.53 ft	1/31/1950
	22.07 ft	4/6/1936
	21.7 ft	2/13/1966
	21.6 ft	3/26/1965
21.2 ft	4/24/2017	

7

8



1 **Holston River Basin**

2 The flood stage on the North Fork of the Holston River at Gate City is 12 feet, which has been  
 3 exceeded 43 times according to NWS Advanced Hydrologic Prediction Service records.  
 4 Moderate flood stage is 15 feet, which has been exceeded 16 times, including four events  
 5 during the HMP analysis period (2015-2020). Four historic events have reached major flood  
 6 stage, exceeding 18 feet, with the most significant event in 1962 with a recorded crest height of  
 7 more than 22 feet. One event, on April 24, 2017, during the HMP analysis period reached major  
 8 flood stage. The table below includes the top 30 events on the Powell River.

9 Big Moccasin Creek, and its major tributary Little Moccasin Creek, are part of the Holston River  
 10 Basin and have a long history of significant flooding. Big Moccasin Creek is fed by tributaries  
 11 originating from high mountain ridges throughout the drainage area. Steep mountainous terrain  
 12 allows for a high potential for rapid flooding following a moderate to significant rain event or  
 13 spring snowmelt. The NWS does not record historic crests on the Big Moccasin Creek.

**TABLE: Historic Crest Heights on the North Fork of the Holston River**  
 Source: *NWS Advanced Hydrologic Prediction Service*

Flood Category	Crest Height	Date
Major Flood Stage (18 ft)	22.50 ft	2/1/1862
	19.79 ft	4/5/1977
	19.36 ft	3/19/2002
	18.54 ft	4/24/2017
Moderate Flood Stage (15 ft)	17.50 ft	2/12/2018
	16.73 ft	1/30/1957
	16.42 ft	3/12/1963
	16.33 ft	2/7/2020
	15.97 ft	4/13/2020
	15.89 ft	2/24/2019
	15.83 ft	3/30/1975
	15.62 ft	12/11/1972
	15.27 ft	5/8/1984
	15.14 ft	3/17/1973
	15.10 ft	11/20/2003
	15.00 ft	2/11/1994
Flood Stage (12 ft)	14.75 ft	8/14/1940
	14.44 ft	2/18/1944
	14.42 ft	1/26/1978
	14.32 ft	4/28/1970
	14.13 ft	12/31/1969
	14.10 ft	4/16/1956
	14.05 ft	4/18/1998
	13.96 ft	1/27/1996
	13.95 ft	5/7/1958
	13.91 ft	11/07/1977
	13.75 ft	1/22/1979
	13.70 ft	1/8/1946
13.66 ft	3/14/1975	
13.62 ft	3/6/1963	



1 Future Probability

2 Based on the Community Vulnerability Risk and Resiliency (CVR2) assessment, detailed in Section 1.6.13 (methodology) and  
 3 Section 1.6.14 (results), this hazard is **Very Frequent/Very Probable** because significant occurrences of this hazard have happened  
 4 recently and will likely occur again in the future. The overall risk ranking for this hazard is **High**.

5 Flooding is the top hazard in Virginia based on both probability and impact. The portions of the LENOWISCO Planning District most  
 6 susceptible to flooding are those directly adjacent to the area's major waterways but can also occur along the smaller tributaries. Due  
 7 to the local terrain, most development in the district is located in the valleys along these rivers. Development generally consists of  
 8 residential and agricultural uses, with commercial districts typically confined within the incorporated towns. A significant amount of  
 9 development in the District is in the floodplain.

10 The 2018 Commonwealth of Virginia Hazard Mitigation Plan (HMP) outlines a ranking of each jurisdiction in the LENOWISCO  
 11 Planning District based on various risk factors. Across the state, flooding is considered the top hazard based on probability and  
 12 impact to all jurisdictions. The City of Norton and Lee County have a "Medium-Low" risk to flooding, while Scott and Wise counties  
 13 are defined as "Medium" risk.

**TABLE: Flood Hazard Ranking Parameters**  
*Source: 2018 Commonwealth of Virginia Hazard Mitigation Plan*

Jurisdiction	Population Vulnerability	Population Density	Injuries & Fatalities	Property Damage	Crop Damage	Events	Geographic Extent	Total Risk Ranking
City of Norton	Low	Medium-High	Low	Medium-Low	Low	Medium-Low	Medium-Low	Medium-Low
Lee County	Medium	Low	Low	Medium-Low	Low	Medium-Low	Medium-Low	Medium-Low
Scott County	Medium	Low	Medium-Low	Medium-Low	Low	Medium	Medium-Low	Medium
Wise County	Medium	Medium	Low	Medium-Low	Low	High	Medium-Low	Medium

14



## 1 Geographic Location

2 Clinch River Basin: The Clinch River is one of the major rivers in the LENOWISCO Planning  
3 District, with a drainage area of roughly 1,145 square miles. Much of this area is situated in  
4 Scott County, but portions are located in Lee and Wise Counties. The Clinch River is fed by  
5 numerous tributaries originating from the high mountain ridges throughout the drainage area.  
6 The primary tributaries to the Clinch are North Fork Clinch, flowing from the northern portion of  
7 the watershed; Stock Creek, flowing from the northwest portion of the watershed; Copper  
8 Creek, flowing from the eastern portion of the watershed; Stony Creek, flowing from the west;  
9 and Guest River, flowing from the northwestern (Wise County) portion of the watershed. Due to  
10 the steep mountainous terrain in the area, the potential for rapid flooding following a moderate  
11 to significant rain event or spring snowmelt is high.

12 The Clinch River, North Fork Clinch, Stock Creek, Copper Creek, and Guest River have been  
13 studied in detail as part of the FEMA Flood Insurance Study, with BFEs determined for the 100-  
14 year flood. The 100-year floodplains along these rivers vary from 100 feet wide in some areas to  
15 more than 1,600 feet wide in other locations, depending on local topography. For areas along  
16 small streams and creeks in the Clinch River area, where minimal development is present and  
17 damage potential is low, approximate methods were used to determine the extent of the  
18 floodplain, and no BFEs were determined.

19 As noted in the previous section, the 100-year flood level has been exceeded on the Clinch  
20 River. This does not preclude the occurrence of another 100-year event in the future, as history  
21 has often proven. The impact of watershed changes over time should be minimal due to the  
22 rural nature of the area.

23 Powell River Basin: The Powell River is another major river in the area, with a drainage area of  
24 roughly 938 square miles. A majority of this area is located within Lee County, with portions of  
25 the watershed in Wise County. The Powell is fed by numerous tributaries originating from the  
26 high mountain ridges throughout the drainage area. The three major tributaries are North Fork  
27 Powell, South Fork Powell, and Callahan Creek. Due to the steep mountainous terrain in the  
28 area, the potential for rapid flooding following a moderate to significant rain event or spring  
29 snowmelt is high. Records of historic events in the district are numerous, and floods on the  
30 Powell River and its tributaries are well documented. The determined flood stage for the Powell  
31 is eight feet. The two largest recorded floods occurred in April 1977 and March 1963, with the  
32 river cresting over 44 feet near Jonesville. As with most floods in this area, information  
33 regarding damages from these events is not readily available. A Virginia State Water Control  
34 Board report (1977) and a TVA report (1972) provide much information regarding previous  
35 floods. Records from these events indicate several buildings inundated with floodwaters, while  
36 roadways were blocked.

37 The Powell River, North Fork of the Powell, South Fork of the Powell, and Callahan Creek have  
38 been studied in detail, with BFEs determined for the 100-year flood. The 100-year floodplains  
39 along these rivers vary from 100 feet wide to more than 1,600 feet, depending on local  
40 topography. For areas along small streams and creeks in this basin, with minimal development  
41 and low damage potential, approximate methods were used to determine the extent of the  
42 floodplain, with no BFEs determined.





1 As noted elsewhere, large floods have occurred on the Powell River. This does not preclude the  
 2 occurrence of a 100-year flood event in the future. The impact of watershed changes over time  
 3 should be minimal, due to the area’s rural nature.

4 Holston River Basin: The North Fork Holston River is the third major river in the district. Most of  
 5 the flood information available is for Big Moccasin Creek with a drainage area of approximately  
 6 95 square miles.

7 The North Fork of the Holston River, Big Moccasin Creek, and Little Moccasin Creek have been  
 8 studied, with BFEs determined for the 100-year flood. The 100-year floodplains along these  
 9 rivers vary from 300 feet wide to more than 1,000 feet, depending on local topography. For  
 10 areas along small streams and creeks in the Holston River area, with minimal development and  
 11 low damage potential, approximate methods were used to determine the extent of the  
 12 floodplain, and no BFEs were determined.

13 As noted, a 100-year flood has not been exceeded on the Holston River, which does not  
 14 preclude the occurrence of a future 100-year event. The impact of watershed changes over time  
 15 should be minimal due to the rural nature of the area.

16 Loss Estimates

17 According to the National Centers for Environmental Information, the total property damage for  
 18 LENOWISCO Planning District from 1950-2016 was \$4,149,000 and the annualized losses  
 19 were \$62,863.63. The NOAA National Centers for Environmental Information (NCEI) Database  
 20 indicates that flooding remains a costly issue for the District with an event occurring as recently  
 21 as February 6, 2020, causing \$196,000 in property damages.

**TABLE: Jurisdictional Annualized Losses from Flooding (1950-2016)**  
 Source: National Centers for Environmental Information

Jurisdiction	Property Damage	Crop Damage	Total Damages	Annualized Losses
City of Norton	\$1,156,000	-	\$1,156,000	\$17,515.15
Lee County	\$1,103,000	-	\$1,103,000	\$16,712.12
Scott County	\$264,000	-	\$264,000	\$4,000
Wise County	\$1,626,000	-	\$1,626,000	\$24,636.36

22  
 23



1 The following tables provide a summary of the extent and value of private property within the 100-year and 500-year flood plains in  
 2 each county in the LENOWISCO Planning District. Across the entire District, there is an estimated value of \$396.43 million of private  
 3 property located in the 100-year floodplain, with more than half of that total located in Wise County. Most of the property located in  
 4 the 100-year flood plain is residential, 97.6% in Lee County, 64.7% in Scott County, and 65.9% in Wise County. Floodplain maps are  
 5 available in the County Hazard Mitigation Annexes.

6

<b>TABLE: Property in the Floodplain in Lee County (in Millions of Dollars) - HAZUS</b>						
<b>Occupancy</b>	<b>100-Year Flood</b>			<b>500-Year Flood</b>		
	<b>Building</b>	<b>Content</b>	<b>Inventory</b>	<b>Building</b>	<b>Content</b>	<b>Inventory</b>
Residential	39.59	20.26	0.0	59.85	50.06	0.0
Commercial	0.21	0.48	0.01	0.70	1.25	0.11
Industrial	0.14	0.30	0.05	0.48	0.22	0.07
Other	0.07	0.20	0.01	0.28	0.27	0.01
<b>Total</b>	<b>40.01</b>	<b>21.24</b>	<b>0.07</b>	<b>61.31</b>	<b>51.80</b>	<b>0.19</b>
						<b>80.85</b>

7

<b>TABLE: Property in the Floodplain in Scott County (in Millions of Dollars) - HAZUS</b>						
<b>Occupancy</b>	<b>100-Year Flood</b>			<b>500-Year Flood</b>		
	<b>Building</b>	<b>Content</b>	<b>Inventory</b>	<b>Building</b>	<b>Content</b>	<b>Inventory</b>
Residential	57.12	29.90	0.0	87.02	68.37	0.0
Commercial	2.21	4.96	0.18	7.35	2.92	0.23
Industrial	8.71	20.24	3.24	32.19	9.65	3.44
Other	1.89	5.96	0.02	7.87	2.37	0.02
<b>Total</b>	<b>69.92</b>	<b>61.05</b>	<b>3.44</b>	<b>134.42</b>	<b>83.31</b>	<b>3.70</b>
						<b>157.04</b>

8

<b>TABLE: Property in the Floodplain in Wise County (in Millions of Dollars) - HAZUS</b>						
<b>Occupancy</b>	<b>100-Year Flood</b>			<b>500-Year Flood</b>		
	<b>Building</b>	<b>Content</b>	<b>Inventory</b>	<b>Building</b>	<b>Content</b>	<b>Inventory</b>
Residential	88.29	43.96	0.0	132.25	108.12	0.0
Commercial	12.91	33.25	0.93	47.08	16.87	1.14
Industrial	1.71	2.87	0.43	5.01	2.16	0.57
Other	3.03	13.23	0.10	16.36	3.97	0.10
<b>Total</b>	<b>105.94</b>	<b>93.32</b>	<b>1.45</b>	<b>200.70</b>	<b>131.12</b>	<b>1.81</b>
						<b>246.49</b>



1 **NFIP: Repetitive Loss and Severe Repetitive Loss**

2 FEMA defines a Repetitive Loss (RL) structure as a structure covered by a contract of flood  
 3 insurance issued under the NFIP, which has suffered flood loss damage on two occasions  
 4 during a 10-year period that bends on the date of the second loss, in which the cost to repair the  
 5 flood damage is 25% of the market value of the structure at the time of each flood loss.

6 From 1978-2016, no unmitigated properties with a Severe Repetitive Loss (SRL) claim above  
 7 \$1 million exist within the LENOWISCO Planning District. An SRL property has at least four  
 8 NFIP claim payments over \$5,000 each (building and contents) or two or more separate claims  
 9 payments with the cumulative amount exceeding the market value of the building.

10 **[Insert Repetitive Loss Data once it is received from the Commonwealth]**

<b>TABLE: NFIP Policies and Claims Paid (1978-2016)</b>			
<i>Source: 2018 Commonwealth of Virginia Hazard Mitigation Plan</i>			
<b>Jurisdiction</b>	<b>Number of Policies</b>	<b>Total Number of Claims since 1978</b>	<b>Total Paid since 1978</b>
City of Norton	39	18	\$94,604
Lee County	71	72	\$795,078
Scott County	73	33	\$441,283
Wise County	328	358	\$2,170,056

11

12 **Vulnerability & Community Development Analysis for Flooding Hazard**

13 Much of the LENOWISCO Planning District is at risk of riverine and flash flooding. The most  
 14 vulnerable areas of the community will be those most affected by floodwaters in terms of the  
 15 potential loss of life, damages to homes and businesses, and disruption of community services  
 16 and utilities. Residential properties are at risk to the most significant damage and property  
 17 losses across the District, but several essential facilities could be moderately or significantly  
 18 damaged in a 100-year or 500-year flood event.

19 Due to existing development and very steep topography outside the river valleys, developable  
 20 land in the LENOWISCO Planning District is scarce. A dominant trend in the area is  
 21 redevelopment, with older, lower value structures replaced by newer construction with higher  
 22 values. This is especially true with older mobile homes replaced by new pre-fabricated modular  
 23 homes. Many of these structures are located in the floodplain, where this redevelopment trend  
 24 is increasing the value of structures at risk to damages due to flooding in the district.

25 ***Impact on LENOWISCO Residents***

26 Damage to housing, vehicles, land, crops, or livestock from flood events can be very high during  
 27 riverine or flash floods. It is possible that flooding can often cause deaths to occur if floodwaters  
 28 become deep/swift enough to sweep away people or vehicles. It is possible that the sick,  
 29 disabled, or elderly may not be mobile enough to escape rising floodwaters and may become  
 30 trapped in their houses. During flooding events, residents may also be at an increased risk of  
 31 waterborne diseases. For many, the psychological impact of major floods can be intense. Loss



1 of loved ones, homes, and livelihoods can obviously create intense psychological and social  
 2 disruption.

3 As shown, a wide variety of building types are present in the floodplains of the District.  
 4 Roughly 67 percent are residential properties, with many of the residential properties either  
 5 mobile homes or low-density residential properties. The table below summarizes the estimated  
 6 number, value, and predominant use of the structures located in the floodplain of all FEMA  
 7 recognized flood sources.

<b>TABLE: Structures at Risk by Flooding Source</b>				
<b>Source: 2013 LENOWISCO Hazard Mitigation Plan</b>				
<b>Flood Source</b>	<b>Estimated Number of Structures</b>	<b>Estimated Total Value</b>	<b>Most Prevalent Building Type</b>	<b>Second Most Prevalent Building Type</b>
<b>Lee County</b>				
Clinch River	25	\$1,250,000	Single Family Residential (65%)	Manufactured Home (20%)
Powell River	690	\$34,000,000	Single Family Residential (64%)	Manufactured Home (20%)
<b>Scott County</b>				
Clinch River	685	\$35,000,000	Single Family Residential (63%)	Manufactured Home (20%)
Holston River	400	\$20,000,000	Single Family Residential (62%)	Manufactured Home (21%)
<b>Wise County</b>				
Clinch River	1,060	\$35,200,000	Single Family Residential (38%)	Manufactured Home (23%)
Levisa Fork	900	\$31,800,000	Single Family Residential (46%)	Manufactured Home (13%)
Powell River	1,375	\$41,245,000	Single Family Residential (48%)	Manufactured Home (10%)
<b>City of Norton</b>				
Guest River	140	\$2,015,000	Single Family Residential (40%)	Manufactured Home (22%)
Powell River	110	\$435,000	Single Family Residential (49%)	Manufactured Home (10%)

8  
 9 Mobile homes are scattered throughout the area. The estimated average value of these  
 10 structures along the various rivers is approximately \$30,000. These structures tend to be more  
 11 vulnerable than other residential types due to their lesser structural stability and flood-prone  
 12 construction materials as well as the reduced means these residents have to protect themselves  
 13 from potential flood damage.

<b>TABLE: Data Profile</b>				
<b>Source: American Community Survey, 2014-2018</b>				
	<b>City of Norton</b>	<b>Lee County</b>	<b>Scott County</b>	<b>Wise County</b>
Median Home Value	\$91,700	\$88,000	\$94,400	\$85,600
Reside in a Mobile Home	15.1% (309)	21.9% (2,583)	25.9% (2,991)	27.7% (4,976)

14



1 **Impact on Essential Facilities, Critical Infrastructure, and Future Assets**

2 The impacts of floodwaters on essential facilities, such as police and fire stations, hospitals, and water or wastewater treatment  
 3 facilities, can greatly increase the overall effect of a flood event on a community. The following tables outline the number of critical  
 4 facilities located in the 100-year and 500-year floodplains in the LENOWISCO Planning District. There are eight essential facilities  
 5 expected to sustain moderate or substantial damage from a 100-year flooding event in the LENOWISCO Planning District. This  
 6 includes one fire station in Lee County, one fire station in Scott County, and three fire stations and three police stations in Wise  
 7 County. Maps of critical facilities located in the floodplain are available in the County Hazard Mitigation Annexes.

**TABLE: Essential Facilities in the Floodplain in Lee County - HAZUS**

Classification	100-Year Flood				500-Year Flood			
	Total	Moderate Damage	Substantial Damage	Loss of Use	Total	Moderate Damage	Substantial Damage	Loss of Use
Emergency Operation Centers	1	0	0	0	1	0	0	0
Fire Stations	10	1	3	2	10	2	3	3
Rescue Squad	4	0	0	0	4	0	0	0
Hospitals	1	0	0	0	1	0	0	0
Police Stations	3	0	1	1	3	0	0	0
Schools	11	0	0	0	11	1	0	1

8

**TABLE: Essential Facilities in the Floodplain in Scott County - HAZUS**

Classification	100-Year Flood				500-Year Flood			
	Total	Moderate Damage	Substantial Damage	Loss of Use	Total	Moderate Damage	Substantial Damage	Loss of Use
Emergency Operation Centers	1	0	0	0	1	0	0	0
Fire Stations	9	1	0	1	9	1	0	1
Rescue Squad	2	0	0	0	2	0	0	0
Hospitals	0	0	0	0	0	0	0	0
Police Stations	4	0	0	0	4	0	0	0
Schools	14	0	0	0	14	0	0	0

9

10





**TABLE: Essential Facilities in the Floodplain in Wise County - HAZUS**

Classification	100-Year Flood				500-Year Flood			
	Total	Moderate Damage	Substantial Damage	Loss of Use	Total	Moderate Damage	Substantial Damage	Loss of Use
Emergency Operation Centers	1	0	0	0	1	0	0	0
Fire Stations	9	3	0	3	9	3	0	3
Rescue Squad	6	0	0	0	6	0	0	0
Hospitals	3	0	0	0	3	0	0	0
Police Stations	11	3	0	3	11	4	1	5
Schools	21	0	0	0	21	0	0	0

1  
 2 There are four wastewater treatment plants located near the rivers or their tributaries, but not located in the floodplain. If one of these  
 3 facilities were to be damaged during a flood event, service could be interrupted, and untreated sewage could be released into  
 4 adjacent waterways.

5 *Impact on the Environment*  
 6 Intense flooding can lead to damage to crops and topsoil, displacement of ecosystems, and the spread of pollution or diseases.

7 *Impact on Operations*  
 8 Flooding events may require significant resources and assistance from local emergency responders as well as state, federal, or  
 9 community service organizations such as the Red Cross. Rapid access for large emergency vehicles has a maximum depth of 0.9-  
 10 1.2m (2.9-3.9ft). If flood depths exceed this amount, first responders may not be able to access areas in need of assistance. Damage  
 11 to critical infrastructure may also inhibit the ability of first responders to carry out emergency operations.



1 Hazard Evaluation and Impact/Consequence Assessment

Frequency & Probability <sup>1</sup>	Very Vulnerable
Potential Magnitude and Scale <sup>1</sup>	Somewhat Vulnerable
Physical Vulnerability Hazard Impact <sup>1</sup>	Vulnerable
Social Vulnerability Hazard Impact <sup>1</sup>	Very Vulnerable
Community Conditions Hazard Impact <sup>1</sup>	Vulnerable
Overall Capability and Capacity <sup>2</sup>	Somewhat Capable
Mitigation <sup>2</sup>	Minimally Capable
Hazard Consequence & Impact Score <sup>1</sup>	Vulnerable
Overall Risk Rating <sup>3</sup>	High

Legend			
Score	1: Vulnerability Rating	2: Capability and Capacity Rating	3: Overall Risk Rating
0 – 24	Minimally Vulnerable	Minimally Capable	Low
25 – 49	Somewhat Vulnerable	Somewhat Capable	Medium
50 – 74	Vulnerable	Capable	High
75 - 100	Very Vulnerable	Very Capable	Extreme
N/A	Not Applicable/Unknown	Not Applicable/Unknown	Not Applicable/Unknown

2  
3

DRAFT



## 1 1.6.6 Karst & Subsidence

2 Land subsidence is the sinking or lowering of the land surface. Most land subsidence in the US  
3 is caused by human activities, such as intensive groundwater withdrawals and petroleum  
4 extraction. In 1999, [USGS reported](#) that 80% of subsidence in the U.S. resulted from human  
5 impact on subsurface water due to land and water-use practices. Some of the most studied  
6 examples are in the Santa Clara Valley of California and the Houston-Galveston region of  
7 Texas. Land subsidence can result in increased coastal flooding along vulnerable shorelines.

8 Three processes cause land subsidence - the compaction of aquifer systems, drainage and  
9 oxidation of organic soils, and the collapse of susceptible rocks also known as Karst (USGS,  
10 1999). Karst is inclusive of many surface and subsurface conditions that can create issues in  
11 engineering geology. Karst areas have distinct features including fissures, tubes, and caves,  
12 which are developed by the solution of carbonate and other rocks. These areas typically feature  
13 sinking streams, cavern openings, and closed depressions. The carbonate rocks that are  
14 typically associated with karst landscapes in Virginia are common in the western mountainous  
15 regions of the state.

16 Karst has the potential for more sudden events like cover-collapse sinkholes which can fall  
17 rapidly. Although these rapid events gain more attention, most sinkholes in karst develop  
18 gradually. Karst formations are significantly influenced by local conditions, but human-caused  
19 and natural. Naturally occurring sinkholes are formed through the slow dissolution of the  
20 underlying rock. Human-caused sinkholes are triggered through changes to the local hydrology,  
21 including pavement runoff and poor drainage along highways.

### 22 Hazard Extent

23 Geographic extent for the Karst hazard is defined as the percent of the jurisdiction where the  
24 risk is "high" for karst-related events. According to the 2018 Commonwealth of Virginia Hazard  
25 Mitigation Plan (HMP), the geographic extent for karst is "low" in all jurisdictions in the  
26 LENOWISCO Planning District, meaning less than 25% of the jurisdiction has a "high" risk of  
27 karst-related events. According to the HMP, the karst hazard cannot be easily expressed in  
28 specific recurrence intervals as with other hazard events.

### 29 History/Previous Occurrences

30 There have been no federal disaster declarations or NOAA NCEI recorded events for  
31 subsidence-related events. Additionally, there have been no recorded karst-related sinkhole  
32 events in the LENOWISCO Planning District or the Commonwealth of Virginia. According to the  
33 2018 Virginia HMP, there is no comprehensive long-term record of past events. There is  
34 significant documentation of land-subsidence, but only in the southern Chesapeake Bay area.

35 While there is no official record of karst sinkhole events, representatives from the LENOWISCO  
36 Planning District reported a variety of sinkholes impacting their jurisdictions, including in Scott  
37 County, Wise County, Norton, Big Stone Gap, Coeburn, Pound, and Wise. These events ranged  
38 from small sinkholes on agricultural property to larger sinkholes damaging roadways and  
39 foundations. These events occurred across the region, with some stemming from poor drainage  
40 and others from collapsed underground mine shafts. Both Scott and Wise counties have  
41 numerous abandoned mines that can lead to land subsidence and water quality issues.



1 Future Probability

2 Based on the Community Vulnerability Risk and Resiliency (CVR2) assessment, detailed in Section 1.6.13 (methodology) and  
 3 Section 1.6.14 (results), this hazard is **Somewhat Probable/Somewhat Frequent** because significant occurrences of this hazard  
 4 have happened on occasion (even though isolated or low impact events may occur with more regularity). The overall risk ranking for  
 5 this hazard is **Medium**.

6 Karst formations are highly influenced by local conditions, both human-caused and natural. All of the jurisdictions in the  
 7 LENO/WISCO Planning District were marked as low risk for both the karst and land subsidence hazards in the 2018 Virginia HMP.  
 8 The analysis below provides detailed ranking parameters.

**TABLE: Karst & Land Subsidence Hazard Ranking Parameters**  
 Source: *Commonwealth of Virginia Hazard Mitigation Plan (HMP), 2018*

Jurisdiction Name	Population Vulnerability	Population Density	Injuries & Fatalities	Property Damage	Crop Damage	Events	Geographic Extent	Total Risk Ranking
City of Norton	Low	Medium-High	Low	Low	Low	Low	Low	Low
Lee County	Medium	Low	Low	Low	Low	Low	Low	Low
Scott County	Medium	Low	Low	Low	Low	Low	Low	Low
Wise County	Medium	Medium	Low	Low	Low	Low	Low	Low

9



1 Geographic Location

2 Land subsidence is a site-specific hazard and poses a risk to areas with low-lying topography  
3 and susceptibility to sea-level rise. In Virginia, land subsidence poses the greatest risk to the  
4 Chesapeake Bay region due to unconsolidated aquifer systems and vulnerable coastline, shown  
5 in the figure below.

6 **FIGURE: Aquifer Systems in the United States**  
7 **Source: USGS Land Subsidence in the United States, 2000**

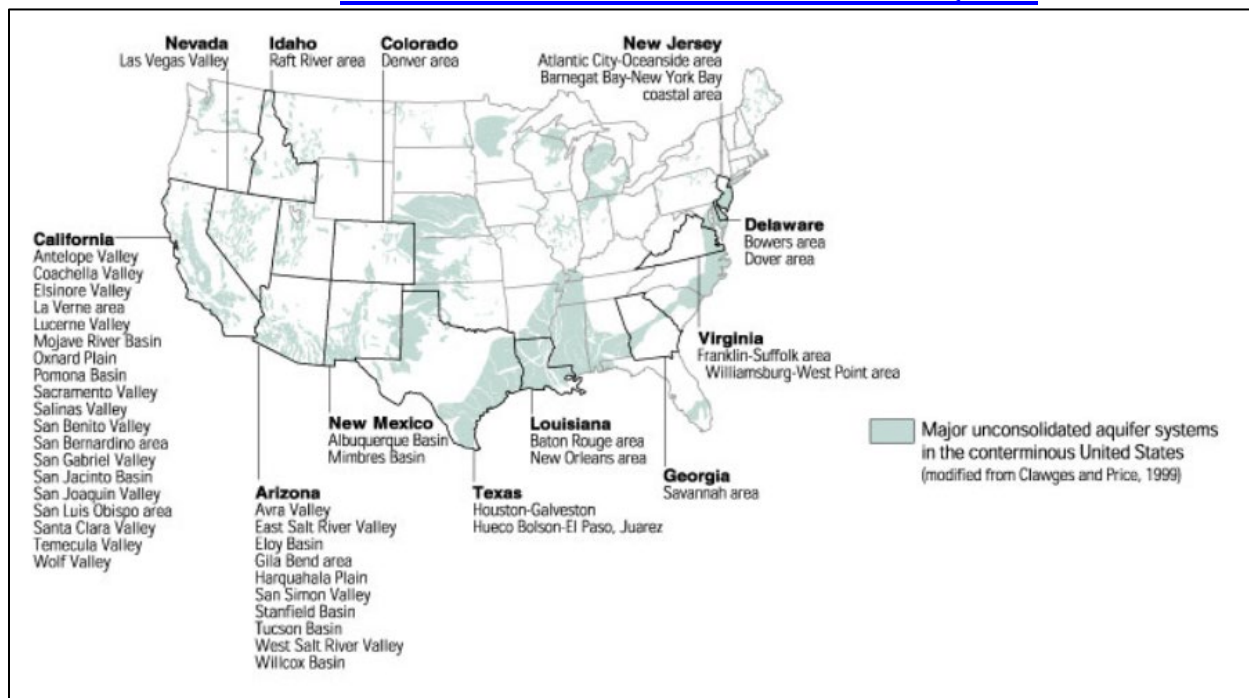

8  
9 The LENOWISCO Planning District includes two regions with distinct contributing factors to  
10 sinkholes and land subsidence. First, much of the region features karst terrain, with landscapes  
11 made from carbonate rock, as depicted in the map below. Lee and Scott counties include  
12 significant karst terrain, accounting for the majority of land area in the counties. Additionally,  
13 southwestern Virginia has many active and abandoned underground mines, including all  
14 jurisdictions in the District. Similar to karst terrain, underground mines pose a risk to certain  
15 types of land use and are prone to collapses that impact the surface. The Virginia Department of  
16 Mines, Minerals, and Energy offers [an interactive map](#) of abandoned mines throughout the  
17 Commonwealth. Abandoned coal mine collapse poses a greater risk to Wise County and the  
18 northern parts of Lee County along the Kentucky border.

19





1  
2

**FIGURE: Karst Geology of Virginia**  
**Source: [Virginia Division of Geology and Mineral Resources](#)**

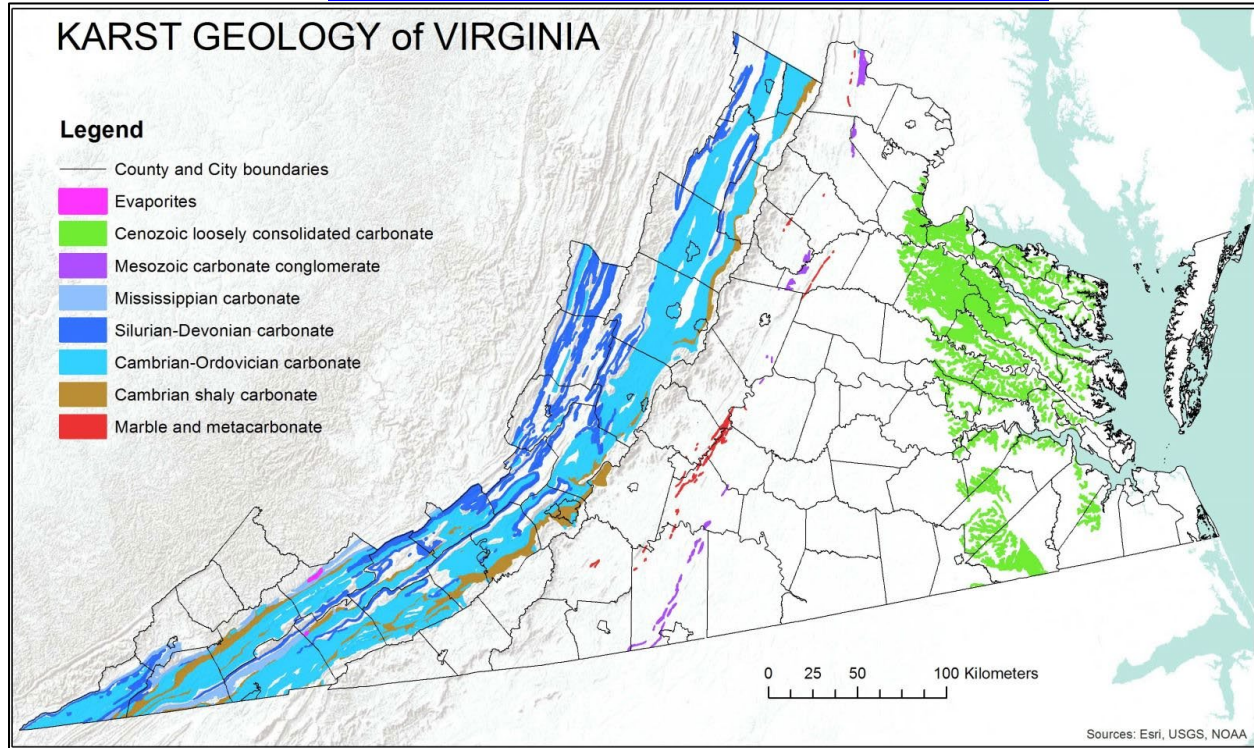

3

#### 4 Loss Estimates

5 Due to a lack of historical data and more detailed mapping, it is difficult to reliably estimate  
6 losses. The 2018 Commonwealth of Virginia Hazard Mitigation Plan does not provide  
7 annualized loss estimated due to the scale of available karst mapping and the lack of available  
8 valuation data.

#### 9 Vulnerability and Community Development Analysis

10 Current land-use practices on karst landscapes pose a risk to buildings, roads, and other  
11 transportation infrastructure, as well as stormwater infrastructure and sewers. By diverting  
12 surface water, creating reservoirs, or otherwise changing local hydrology, development can  
13 accelerate sinkhole formation. Human-induced sinkholes have doubled since 1930, in addition  
14 to steep increases in related insurance claims (FEMA). Subsidence is generally not covered by  
15 standard homeowners' insurance.

#### 16 *Impact on LENOWISCO Residents*

17 Sinkholes can damage homes and other property, and residents experiencing impacts will be  
18 very localized. Any decrease in elevation through land subsidence poses a threat to residents  
19 and property by exacerbating flood conditions.

20

21



1 ***Impact on Essential Facilities, Critical Infrastructure, and Future Assets***

2 Karst-related sinkholes cause localized but significant damage to property and infrastructure. As  
3 the majority of the LENOWISCO Planning District includes karst terrain, it is not possible to  
4 assess the specific risk to essential facilities.

5 Sinkholes can create significant impacts on transportation and water infrastructure. Virginia  
6 Department of Transportation recorded 500 sinkholes damaging roads across the  
7 Commonwealth. Additionally, a sinkhole provides a direct path between surface water and  
8 groundwater aquifers. Sinkholes can significantly increase the potential for polluted drinking  
9 water or other water contamination. Virginia has experienced contaminated karst aquifers from  
10 petroleum products, agricultural products, sewage, household garbage, and other sources. The  
11 Virginia Health Department discourages using karst springs as a drinking water supply and  
12 requires periodic testing of springs that are used.

13 Future infrastructure and development in karst landscapes will be vulnerable to sinkholes and  
14 other land subsidence events. Vulnerability will further increase for areas that do not limit  
15 changes to natural hydrologic systems. Groundwater contamination is a significant vulnerability  
16 in karst landscapes, and the safety of drinking water supplies should be an important  
17 consideration for future development.

18 ***Impact on the Environment***

19 Groundwater contamination is the most significant environmental impact associated with karst  
20 landscapes. As described above, karst terrain is highly vulnerable to water contamination and  
21 pollution, accelerated by groundwater pumping and poor land-use management. a common  
22 problem in populated areas overlying karst terrain. Depending on the contaminant, chemicals or  
23 other pollution could remain in the groundwater for years after initial exposure.

24 ***Impact on Operations***

25 Sinkholes could disrupt utilities, transportation routes, and the delivery of emergency services  
26 based on their location. Any disruptions would likely be limited and very localized.

27



1 Hazard Evaluation and Impact/Consequence Assessment

Frequency & Probability <sup>1</sup>	Somewhat Vulnerable
Potential Magnitude and Scale <sup>1</sup>	Minimally Vulnerable
Physical Vulnerability Hazard Impact <sup>1</sup>	Vulnerable
Social Vulnerability Hazard Impact <sup>1</sup>	Vulnerable
Community Conditions Hazard Impact <sup>1</sup>	Vulnerable
Overall Capability and Capacity <sup>2</sup>	Minimally Capable
Mitigation <sup>2</sup>	Minimally Capable
Hazard Consequence & Impact Score <sup>1</sup>	Vulnerable
Overall Risk Rating <sup>3</sup>	Medium

Legend			
Score	1: Vulnerability Rating	2: Capability and Capacity Rating	3: Overall Risk Rating
0 – 24	Minimally Vulnerable	Minimally Capable	Low
25 – 49	Somewhat Vulnerable	Somewhat Capable	Medium
50 – 74	Vulnerable	Capable	High
75 - 100	Very Vulnerable	Very Capable	Extreme
N/A	Not Applicable/Unknown	Not Applicable/Unknown	Not Applicable/Unknown

2  
3

DRAFT



## 1 1.6.7 Landslide

2 Landslides are a serious geologic hazard common to almost every state in the United States.  
3 Across the country, landslides cause over \$1 billion in damages and between 25 to 50 deaths  
4 each year ([USGS](#)). Globally, landslides cause billions of dollars in damage and thousands of  
5 deaths and injuries.

6 A landslide is the downslope movement of soil and rock - a broad term that includes a variety of  
7 movements. Gravity is the driving force for landslides, but heavy rainfall, rapid snowmelt,  
8 steepening slopes due to erosion or stream incision, or earthquakes can all trigger landslide  
9 events. Human impacts, including slope modification or drainage alteration, can increase the  
10 likelihood of landslides. Wildfires can lower the threshold of precipitation needed to initiate a  
11 landslide event.

12 There are several types of landslides or earth movements, including:

- 13 • **Rockfalls:** large pieces of bedrock breaking off a cliff face and tumbling downslope
- 14 • **Rockslides:** a detached section of bedrock slides down an inclined surface, frequently  
15 along a bedding plane
- 16 • **Earth slides:** masses of soil moving down a slip face, usually on top of the bedrock
- 17 • **Creep:** slow, continuous, imperceptible downslope movement of soil and rock particles
- 18 • **Rotational Slides or Slumps:** result from the rotation of a cohesive unit of soil or rock  
19 down a slip surface, leaving a curved scarp
- 20 • **Debris flows:** develop on steep slopes because of heavy rainfall that saturates the soil,  
21 which under the extra weight and lubrication breaks loose and becomes slurry that takes  
22 everything with it, including large trees and houses. Channeled debris flows can reach  
23 speeds approaching a hundred miles an hour and strike without warning.

24 The location of landslides is based on both natural features and human-made conditions. The  
25 Virginia Division of Geology and Mineral Resources points to research from North Carolina  
26 demonstrating that about 56% of landslides occurred on slopes altered by development  
27 ([VDGMR](#)). Natural features typically include topography, geology, and precipitation.

- 28 • **Topography:** with steeper slopes comes greater forces of gravity, increasing the  
29 potential for failure of the slope's rocks or soils.
- 30 • **Geography:** The strength of the rock, soil, or debris dictates the slope's ability to resist  
31 the forces of gravity.
- 32 • **Precipitation:** water seeps into gaps between soil and rock, decreasing the slope's  
33 strength and resistance. Heavy rain is a key factor in landslide incidence.

34 In the LENOWISCO Planning District, there is an increased potential for landslides along  
35 roadways due to erosion or undercutting. Ground cover and vegetation on the slope can also  
36 influence the likelihood of a landslide event. Additionally, thin surface soils and steep  
37 topography throughout the District create conditions favorable to erosion and landslides. The  
38 widespread construction of roads, clearing of lands, and preparation of development sites on  
39 very steep slopes exacerbate the problem.

40

41



## 1 Hazard Extent

2 USGS offers six categories of landslide risk based on both susceptibility and  
3 incidence. **Susceptibility** is the relative likelihood of future landslides based on site-specific  
4 characteristics, such as topography and precipitation. **Incidence** is the number of landslides  
5 that have historically occurred in the area. High incidence is when greater than 15% of the area  
6 has been involved, moderate is between 1.5 - 15% of the area, and low incidence is less than  
7 1.5% of the area. The six categories, from highest to lowest risk, include:

- 8 • High susceptibility and high incidence (>15%)
- 9 • High susceptibility and moderate incidence (1.5% - 15%)
- 10 • High susceptibility and low incidence (<1.5%)
- 11 • Moderate susceptibility and moderate incidence (1.5% - 15%)
- 12 • Moderate susceptibility and low incidence (<1.5%)
- 13 • Low susceptibility and low incidence (<1.5%)

## 14 History/Previous Occurrences

15 There are no official records indicating the location or extent of landslides in the LENOWISCO  
16 Planning District. No debris flow events are recorded in the National Oceanic and Atmospheric  
17 Administration National Centers for Environmental Information ([NOAA NCEI](#)) storm events  
18 database. There have been no federal disaster declarations for landslide events in the District,  
19 and no events are noted in the 2018 Commonwealth of Virginia HMP. Most recorded landslide  
20 events are obtained through the Virginia Department of Transportation, as the events are often  
21 concentrated adjacent to roadways. Smaller landslides not occurring along roadways are not  
22 reported or recorded at this time.

23 While there is no official record of landslide events, representatives from the LENOWISCO  
24 Planning District reported a variety of events impacting their jurisdictions, including in two  
25 significant slides in Big Stone Gap and Pound. The 2019 landslide in Big Stone Gap threatened  
26 the municipal water supply at Big Cherry Lake Dam. The landslide in Pound impacted a vacant  
27 property but remains a threat to a residential area above the slide. Most of the other jurisdictions  
28 in the District reported landslides impacting roadways in and out of town, detailed in the  
29 Geographic Location section below. These roads are typically maintained by the Virginia  
30 Department of Transportation who is responsible for mitigating the hazard and addressing any  
31 damages.





1 Future Probability

2 Based on the Community Vulnerability Risk and Resiliency (CVR2) assessment, detailed in Section 1.6.13 (methodology) and  
 3 Section 1.6.14 (results), this hazard is **Somewhat Probable/Somewhat Frequent** because significant occurrences of this hazard  
 4 have happened on occasion (even though isolated or low impact events may occur with more regularity). The overall risk ranking for  
 5 this hazard is **Medium**.

6 As noted, landslides are caused by a combination of many different factors. In some instances, the potential for a landslide to occur  
 7 at a particular location can be identified based on topographical and geologic factors, as well as other physical indicators. One of the  
 8 best indicators of future landslide events is a history of past landslide activity, as these areas have demonstrated susceptibility to  
 9 landslide occurrence. Historically, detailed records have not been maintained by local or county governments, therefore the data  
 10 required to identify all known high landslide risk areas located within the LENOWISCO Planning District is not available.

11 The 2018 Commonwealth of Virginia Hazard Mitigation Plan (HMP) outlines a ranking of each jurisdiction in the LENOWISCO  
 12 Planning District based on various risk factors. The City of Norton and Wise County are two jurisdictions considered "Medium-Low"  
 13 risk to landslide events according to the 2018 HMP, as detailed below.

**TABLE: Landslide Hazard Ranking Parameters**  
*Source: 2018 Commonwealth of Virginia Hazard Mitigation Plan*

Jurisdiction	Population Vulnerability	Population Density	Injuries & Fatalities	Property Damage	Crop Damage	Events	Geographic Extent	Total Risk Ranking
City of Norton	Low	Medium-High	Low	Low	Low	Low	Medium-High	Medium-Low
Lee County	Medium	Low	Low	Low	Low	Low	Low	Low
Scott County	Medium	Low	Low	Low	Low	Low	Low	Low
Wise County	Medium	Medium	Low	Low	Low	Low	Medium-High	Medium-Low



1 Geographic Location

2 Landslides are most common in the mountainous terrain of Virginia. Steep slopes and fractured  
3 bedrock combined with heavy rainfall lead to areas that are prone to significant movement.  
4 More than half of the Commonwealth is considered to have moderate or high potential of  
5 landslides, including the LENOWISCO Planning District, as shown in the map below.

6 **FIGURE: Landslide Overview Map of Virginia**

7 **Source: [Virginia Division of Geology and Mineral Resources, adapted from USGS](#)**

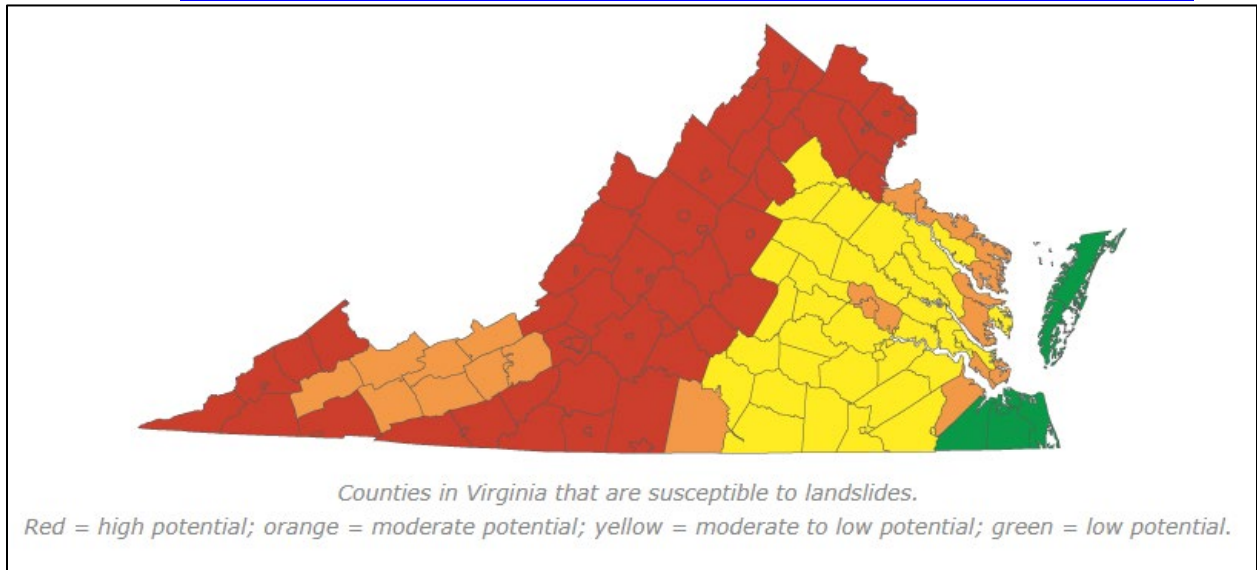



1 The map below illustrates landslide susceptibility in the three counties of the LENOWISCO  
2 Planning District. Wise County and the City of Norton, and the northern sections of Lee and  
3 Scott counties, have both high incidence and high susceptibility to a landslide event. Several  
4 other sections of the District, indicated in orange, have moderate incidence and high  
5 susceptibility.

6 **Figure: LENOWISCO Planning District Landslide Hazard Susceptibility Risk Map**

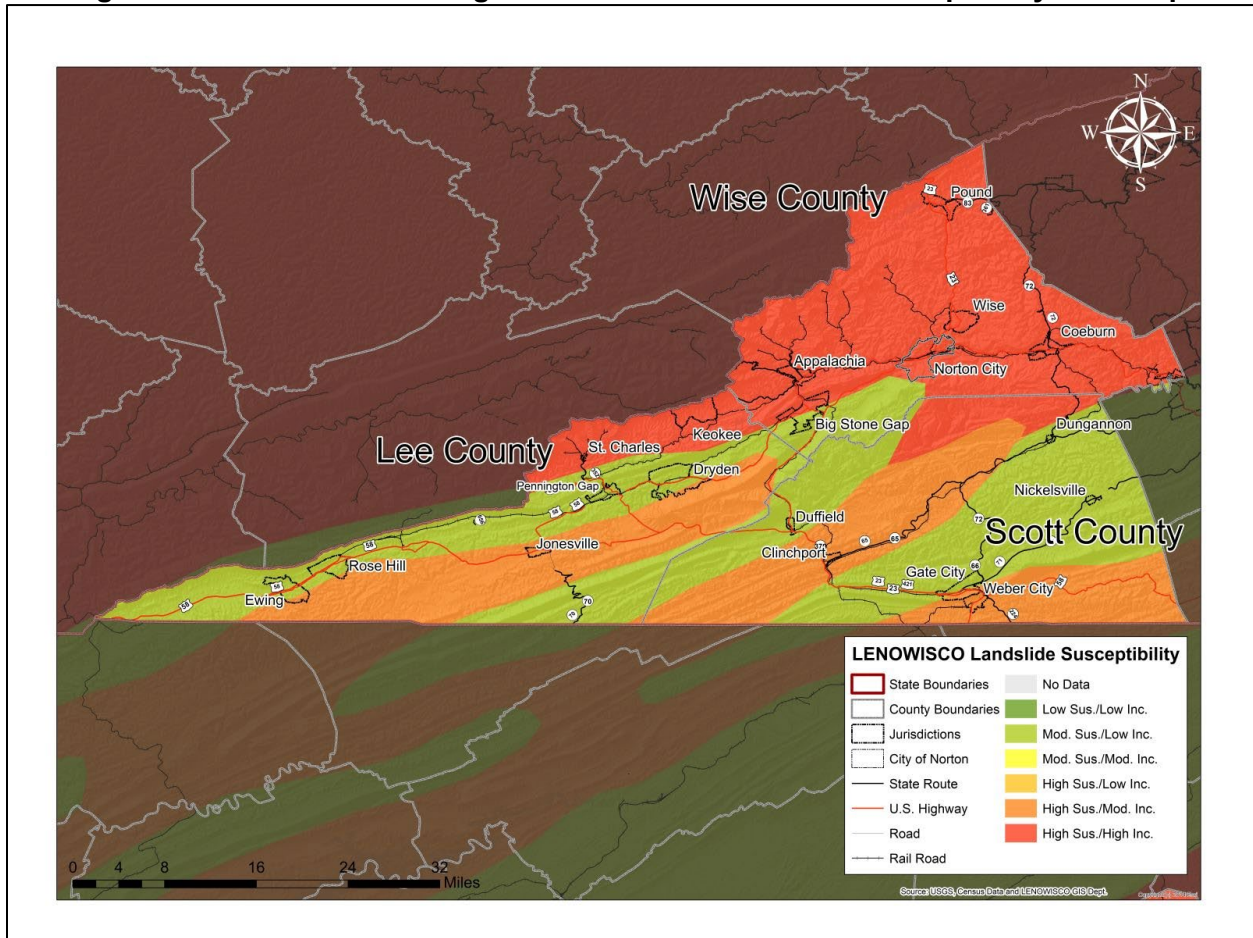

8 As depicted in the map above, many of the U.S. Highways throughout the District are located in  
9 high susceptibility landslide areas. According to records from the Virginia Department of  
10 Transportation, the following roadways have experienced landslide events:

11 **[Included updated information from VDOT]**

12 **Lee County**

13 VDOT has documented seven locations in Lee County where historic landslide activity has  
14 occurred. All these landslide areas are included in the northern and eastern portions of the  
15 county. These locations include:

- 16 • U.S. 421 west of Pennington Gap and just east of the Kentucky border
- 17 • Multiple locations along Rt. 606 north of Pennington Gap, both east and west of Rt. 721



- 1 • Rt. 611 approximately 2.25 miles west of U.S. 23
- 2 • Multiple locations along U.S. 58 & U.S. 421 east of Rt. 612
- 3 • Rt. 621 approximately 1.0 mile west of Rt. 622

#### 4 *Scott County*

5 In Scott County, VDOT has documented historic landslide locations in four major areas,  
6 primarily in the southern portion of the county. These locations include:

- 7 • Multiple locations along U.S. 58 & U.S. 421, east of Rt. 726 and west of Rt. 638
- 8 • Multiple locations along U.S. 23, west of Gate City, both east and west of Rt. 643
- 9 • Along Rt. 72 north of Gate City and approximately 1.2 miles north of Rt. 627
- 10 • Along Rt. 604 approximately 3 miles west of Rt. 622

#### 11 *Wise County*

12 VDOT has identified seven primary landslide locations in Wise County, most of which are  
13 located along major roadways. These locations include:

- 14 • Black Mountain section of Rt. 160
- 15 • Norton Bypass section of U.S. 23
- 16 • Indian Creek Mountain north of Wise
- 17 • Pound Bypass section of U.S. 23, just north of J. W. Adams School
- 18 • U.S. 23 between the north junction with Rt. 610 and the base of the mountain in Powell
- 19 Valley
- 20 • U.S. 23 in the town of Appalachia
- 21 • Alt. U.S. 58 in the vicinity of Route 657

#### 22 Loss Estimates

23 There is not currently a reliable method to calculate annualized losses due to landslide events.  
24 Using data available in the NCEI Storm Events Database, the 2018 Commonwealth of Virginia  
25 HMP estimated an annualized damage of \$8,333 based on recorded events between 1998 and  
26 2016.

27



## 1 Vulnerability and Community Development Analysis for Landslide Hazard

2 Due to the extremely steep slopes throughout the LENOWISCO Planning District, virtually all  
3 development in the area is at high risk to the effects of landslides. The vulnerability of specific  
4 structures and assets can only be determined by a detailed investigation of the site  
5 characteristics, primarily the proximity to at-risk slopes. A majority of the more densely  
6 developed areas of the District are located in areas with more gradual slopes, reducing the risk  
7 of widespread damages in densely developed areas. However, a majority of the unincorporated  
8 areas throughout the District have extremely steep slopes. The potential for landslide damage to  
9 structures in these areas could be high.

### 10 *Impact on LENOWISCO Residents*

11 Homeowners insurance typically does not cover landslide damage, resulting in significant  
12 financial risk for LENOWISCO residents living on or near steep slopes. Socioeconomically  
13 disadvantaged individuals are at the greatest risk of financial instability due to property damages  
14 or extended periods of isolation due to blocked roadways.

### 15 *Impact on Essential Facilities, Critical Infrastructure, and Future Assets*

16 Landslides tend to have very localized impacts but could include damages to property and  
17 buildings or reduced property values in areas susceptible to landslides.

18 Based on past occurrences, the most vulnerable assets located within the LENOWISCO  
19 Planning District are its roadways. Many of the roads in the area traverse steep slopes  
20 increasing the vulnerability to damage. Damage to a roadway affected by a landslide can vary  
21 from partial blockage to total destruction. In addition to the damage to the road itself, more  
22 significant economic and safety impacts may be felt by the community due to the loss of  
23 function of the roadway. Many roadways throughout the district provide the only direct access  
24 from one community to another, or potentially the only access to certain remote areas. Reduced  
25 access can increase the response time of emergency vehicles, creating a potentially serious  
26 threat to public safety.

27 Any future development occurring on or near steep slopes would be at risk to the impacts of  
28 landslide events.

### 29 *Impact on the Environment*

30 Landslides can cause animal deaths, loss of agricultural and forest productivity, damming or  
31 alteration of streams and rivers, and reduced water quality.

### 32 *Impact on Operations*

33 Blocked roadways due to landslide events can significantly impact operations, especially the  
34 transportation of people, goods, and services between communities.

35





1 Hazard Evaluation and Impact/Consequence Assessment

Frequency & Probability <sup>1</sup>	Somewhat Vulnerable
Potential Magnitude and Scale <sup>1</sup>	Minimally Vulnerable
Physical Vulnerability Hazard Impact <sup>1</sup>	Vulnerable
Social Vulnerability Hazard Impact <sup>1</sup>	Vulnerable
Community Conditions Hazard Impact <sup>1</sup>	Vulnerable
Overall Capability and Capacity <sup>2</sup>	Somewhat Capable
Mitigation <sup>2</sup>	Somewhat Capable
Hazard Consequence & Impact Score <sup>1</sup>	Vulnerable
Overall Risk Rating <sup>3</sup>	Medium

Legend			
Score	1: Vulnerability Rating	2: Capability and Capacity Rating	3: Overall Risk Rating
0 – 24	Minimally Vulnerable	Minimally Capable	Low
25 – 49	Somewhat Vulnerable	Somewhat Capable	Medium
50 – 74	Vulnerable	Capable	High
75 - 100	Very Vulnerable	Very Capable	Extreme
N/A	Not Applicable/Unknown	Not Applicable/Unknown	Not Applicable/Unknown

2  
3

DRAFT



## 1 1.6.8 Non-Rotational Winds

2 Tropical cyclones can cause significant severe weather events in more inland communities,  
 3 including storm surge flooding, extreme rainfall, thunderstorms, lightning, severe winds, and  
 4 tornadoes. Riverine flooding can also result from significant storm surges that push inland. With  
 5 extreme rainfall and severe wind, communities can also experience secondary impacts from  
 6 landslides, debris flows, downed trees, and power outages.

7 Other non-rotational wind events include derechos, which are a widespread, straight-line  
 8 windstorm linked to a band of severe thunderstorms. Derechos in Virginia mainly occur in June  
 9 and July with the ability to produce damage comparable to tornadoes. Derechos consist of a  
 10 wind damage area extending more than 240 miles and featuring wind gusts of at least 58 mph.

### 11 Hazard Extent

12 The most significant non-rotational wind hazard in Virginia are tropical cyclones/hurricanes,  
 13 which are categorized on the Saffir-Simpson Hurricane Damage Scale, included in the table  
 14 below. Virginia has experienced hurricane events reaching Category 2, including Hurricane  
 15 Sandy in 2012. Meteorologists consider the water off the Virginia coast too cool to support a  
 16 Category 5 storm. It is important to know that the intensity and damages caused by hurricane  
 17 winds, as described in the table below, are based on potential property damage along the coast  
 18 from a hurricane landfall. As the LENOWISCO Planning District is several hundred miles inland,  
 19 wind damage from a hurricane event would be significantly less than as described on the Saffir-  
 20 Simpson scale.

<b>TABLE: Saffir-Simpson Hurricane Damage Scale</b>			
<b>Source: National Weather Service National Hurricane Center</b>			
<b>Category</b>	<b>Wind Speeds</b>	<b>Damage Potential</b>	<b>Damage Description (Wind Only)</b>
Tropical Depression	<38 mph	Negligible	Wind effects: Scattered trees down, scattered power outages, some roads blocked due to downed trees and power lines. For example, neighborhoods could lose power for several days.
Tropical Storm	39-73 mph		
1	74-95 mph	Minimal	Very dangerous winds will produce some damage: Well-constructed frame homes could have damage to roof, shingles, and vinyl siding and gutters. Large branches of trees will snap and shallowly rooted trees may be toppled. Extensive damage to power lines and poles likely will result in power outages that could last a few to several days.
2	96-110 mph	Moderate	Extremely dangerous winds will cause extensive damage: Well-constructed frame homes could sustain major roof and siding damage. Many shallowly rooted trees will be snapped or uprooted and block numerous roads. Near-total power loss is expected with outages that could last from several days to weeks.



3 (Major)	111-129 mph	Extensive	Devastating damage will occur: Well-built framed homes may incur major damage or removal of roof decking and gable ends. Many trees will be snapped or uprooted, blocking numerous roads. Electricity and water will be unavailable for several days to weeks after the storm passes.
4 (Major)	130-156 mph	Extreme	Catastrophic damage will occur: Well-built framed homes can sustain severe damage with loss of most of the roof structure and/or some exterior walls. Most trees will be snapped or uprooted and power poles downed. Fallen trees and power poles will isolate residential areas. Power outages will last weeks to possibly months. Most of the area will be uninhabitable for weeks or months.
5 (Major)	>157 mph	Catastrophic	Catastrophic damage will occur: A high percentage of framed homes will be destroyed, with total roof failure and wall collapse. Fallen trees and power poles will isolate residential areas. Power outages will last for weeks to possibly months. Most of the area will be uninhabitable for weeks or months.

1

2 History/Previous Occurrences

3 Damaging winds from severe thunderstorms occur throughout southwestern Virginia on a  
 4 regular basis. Wind damages are typically localized throughout the region and include broken  
 5 tree limbs, blown down trees, damage to power lines, and moderate building damage.

6 The relatively large distance between the district and the Atlantic Coast limit the impacts of the  
 7 winds associated with hurricanes and tropical storms. Because the highest winds speeds  
 8 associated with a hurricane or tropical storm are typically located to the east of the storm's eye,  
 9 and the paths of most of these storms are to the east of the LENOWISCO Planning District,  
 10 extremely high winds from these events are rare.

11 During the analysis timeframe (2015-2020) for the HMP update, 40 wind events (38  
 12 thunderstorm wind events and 2 high wind events) were recorded in the NOAA National Centers  
 13 for Environmental Information (NCEI) database. Many events impacted multiple areas in the  
 14 LENOWISCO district. There was one federal disaster declaration for Hurricane Florence  
 15 (#3403) on September 11, 2018, including the entire state of Virginia. No damages were  
 16 reported in the LENOWISCO Planning District from this event.



**TABLE: High Wind and Thunderstorm Wind Events in LENOWISCO from 01/01/2015 to 08/01/2020**  
 Source: [www.ncdc.noaa.gov/stormevents](http://www.ncdc.noaa.gov/stormevents)

Jurisdiction	Event Type	Dates of Occurrence	Direct Deaths	Direct Injuries	Reported Property Damage	Reported Crop Damage	Indirect Deaths	Indirect Injuries
City of Norton	Thunderstorm Wind	7/13/2015 7/14/2015 5/29/2019	0	0	\$0	\$0	0	0
Lee County	Thunderstorm Wind	4/25/2015	0	0	\$5,000 (4/25/2015)	0	0	0
		7/13/2015						
		7/14/2015						
		5/7/2016						
		6/21/2016						
		6/23/2016						
		7/6/2016						
		3/1/2017						
		5/11/2017						
		5/20/2017						
7/6/2017								
4/4/2018								
6/3/2018								
7/20/2018								
5/18/2019								
6/21/2019								
10/31/2019								
7/23/2020								







1 Future Probability

2 Based on the Community Vulnerability Risk and Resiliency (CVR2) assessment, detailed in Section 1.6.13 (methodology) and  
 3 Section 1.6.14 (results), this hazard is **Very Frequent/Very Probable** because significant occurrences of this hazard have happened  
 4 recently and will likely occur again in the future. The overall risk ranking for this hazard is **High**.

5 Non-rotational wind events are a regular occurrence in the LENOWISCO Planning District. The 2018 Commonwealth of Virginia  
 6 Hazard Mitigation Plan (HMP) outlines a ranking of each jurisdiction in the District based on various risk factors. Across the state,  
 7 non-rotational wind is considered the top hazard based on probability and impact to all jurisdictions. Lee and Scott counties have a  
 8 "Medium-Low" risk to wind events, while the City of Norton and Wise County are considered "Medium" risk.

**TABLE: Non-Rotational Wind Hazard Ranking Parameters**  
*Source: 2018 Commonwealth of Virginia Hazard Mitigation Plan*

Jurisdiction Name	Population Vulnerability	Population Density	Injuries & Fatalities	Property Damage	Crop Damage	Events	Geographic Extent	Total Risk Ranking
City of Norton	Low	Medium-High	Low	High	Medium-High	Medium-Low	Low	Medium
Lee County	Medium	Low	Low	High	Medium	Medium-Low	Low	Medium-Low
Scott County	Medium	Low	Medium	Medium-High	Low	Medium-Low	Low	Medium-Low
Wise County	Medium	Medium	Low	Medium-High	High	Medium-Low	Low	Medium

9



## 1 Geographic Location

2 Most hurricanes affect eastern Virginia due to its proximity to the coast, but more recent impacts  
3 from tropical cyclones have extended further inland, including Hurricane Irma in 2017. Virginia  
4 typically sees hurricanes between June and November. A storm originating in the Atlantic is  
5 defined as a hurricane when the maximum sustained winds reach 74 miles per hour. Below this  
6 level, it is defined as either a tropical storm or tropical depression.

7 With tropical cyclones approaching from the coast, the eastern parts of Scott and Wise counties  
8 are at slightly higher risk than Lee County. However, LENOWISCO is uniformly at risk to other  
9 types of non-rotational winds, including derechos. High wind events, primarily severe  
10 thunderstorms, have historically occurred in every jurisdiction. LENOWISCO Planning District is  
11 not classified as an area with a higher-than-average base wind speed nationally. According to  
12 the Virginia Uniform Statewide Building Code (USBC), the minimum design wind speed for the  
13 area is 90 mph. It is worth noting that localized geography, such as mountain ranges and  
14 gorges, can contribute to potential damages caused by wind events.

## 15 Loss Estimates

16 The vulnerability of a building to a high wind event is based on design wind pressures and  
17 building construction types.

- 18 • **Design Wind Pressures:** Buildings must be designed to withstand both external and  
19 internal wind pressures on the structural framing and exterior elements. Virginia's  
20 building code dictates to what design wind speed a structure must be designed. The  
21 resistance to wind damage based on these code requirements is only effective to the  
22 level the requirements are enforced, and no comprehensive data on the date built for  
23 these structures exist for the district.
- 24 • **Building Type:** The type of building construction has an impact on potential damages  
25 from high wind events. A summary of basic building types – listed in order of decreasing  
26 vulnerability (from most to least vulnerable) – is provided below.
  - 27 ○ **Manufactured:** This building type includes manufactured buildings produced in  
28 large numbers of identical or smaller units; typically include light metal structures  
29 or mobile homes.
  - 30 ○ **Non-Engineered Wood:** Wood buildings not specifically engineered during  
31 design; may include single and multi-family residences, some 1-2 story  
32 apartment units, and small commercial buildings.
  - 33 ○ **Non-Engineered Masonry:** Masonry buildings not specifically engineered during  
34 design; may include single and multi-family residences, some 1-2 story  
35 apartment units, and small commercial buildings.
  - 36 ○ **Lightly Engineered:** Structures may combine masonry, light steel framing,  
37 open-web steel joists, wood framing, and wood rafters. Some portions of these  
38 buildings have been engineered while others have not. Examples include motels,  
39 commercial, and light industrial buildings.
  - 40 ○ **Fully Engineered:** These typically have been designed for a specific location,  
41 and have been fully engineered during design. Examples include high-rise office  
42 buildings, hotels, hospitals, and most public buildings.



1 Other types of structures found throughout the district that are vulnerable to damages during  
2 high wind events are metal framed buildings, primarily associated with light industrial buildings,  
3 as well as some agricultural buildings. According to the Virginia USBC, agricultural buildings,  
4 such as barns and silos, are required to meet minimum requirements and be constructed in  
5 accordance with the state building code. Although the potential for human losses in these  
6 structures may be lower, the potential for high amounts of damages is significant.

7 Other factors that affect the potential for damage include height, shape, and the integrity of the  
8 building envelope. Taller buildings and those with complex shapes and complicated roofs are  
9 subject to higher wind pressures than those with simple configurations. The building envelope is  
10 composed of exterior building components and cladding elements including doors and windows,  
11 exterior siding, and roof coverings, and sheathing. Any failure or breach of the envelope can  
12 lead to increased pressures on the structure's interior, further damage to contents and framing,  
13 and possible collapse.

14 The LENOWISCO Planning District is in VDEM Region 4, which includes 18 counties in  
15 southwestern Virginia. The 2018 Commonwealth of Virginia HMP analyzed potential damages  
16 by VDEM region based on a 100-year wind event using FEMA's HAZUS-MH. The analysis  
17 showed that most building damage would be to residential structures, but overall damage would  
18 be minor. The analysis estimated that two buildings in the region would be moderately damaged  
19 by the event, as illustrated in the figure below.

20 **FIGURE: VDEM Region 4 - 100-Year Probabilistic Wind Event, Expected Building Damage**  
21 **by Occupancy**

22 *Source: [2018 Commonwealth of Virginia Hazard Mitigation Plan](#)*

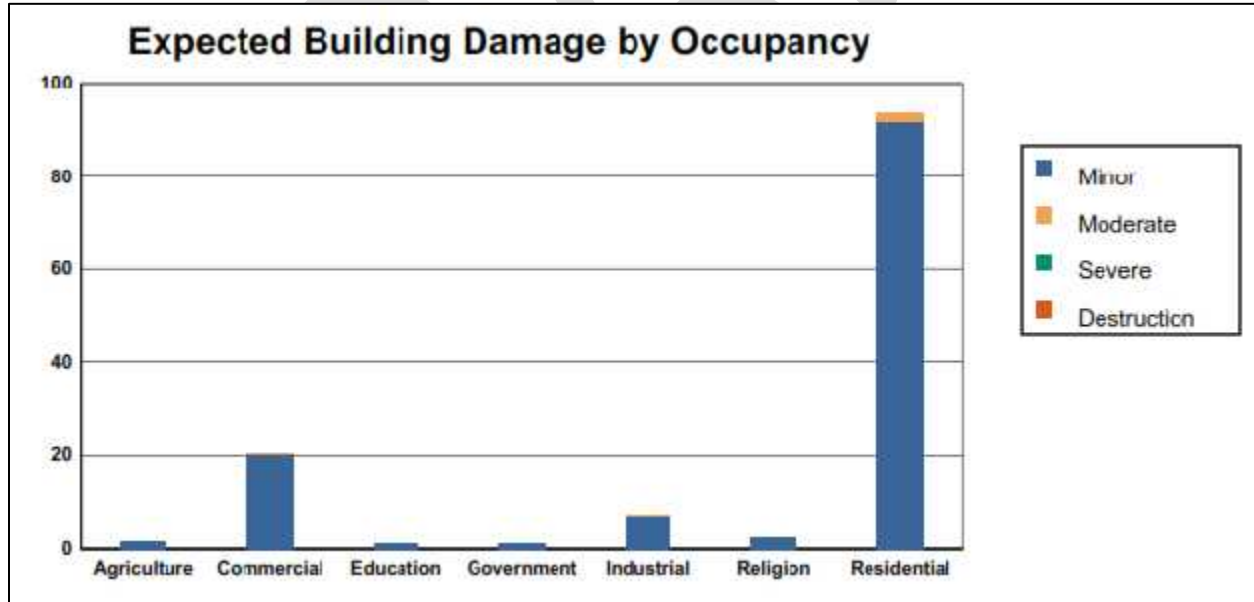

23  
24



1 HAZUS-MH also estimated economic losses for a 100-year wind event, based on the total direct  
 2 losses for the entire VDEM Region 4. The table below shows the annualized loss estimates for  
 3 the LENOWISCO Planning District.

<b>TABLE: HAZUS-MH Hurricane Wind Annualized Loss</b> <i>Source: 2018 Commonwealth of Virginia Hazard Mitigation Plan</i>	
Lee County	\$19,871
Scott County	\$20,747
Wise County	\$32,629

4  
 5 The following building types are required by the American Society of Civil Engineers to be  
 6 designed for a 100-year wind event:

- 7 1. Office buildings where more than 300 people congregate in one area;
- 8 2. Buildings that will be used for a hurricane or another emergency shelter;
- 9 3. Buildings housing a daycare center with a capacity greater than 150 occupants;
- 10 4. Buildings designated for emergency preparedness, communication, or emergency  
 11 operation center or response;
- 12 5. Buildings housing critical national defense functions; and
- 13 6. Buildings containing sufficient quantities of hazardous materials.

14 Using these building types, and the potential wind speeds for the LENOWISCO Planning  
 15 District, potential damages can be expressed in terms of a percentage of the building and  
 16 contents values. ASCE 7 categorizes the southwestern Virginia area as a 90-mph wind zone,  
 17 based on a 50-year recurrence interval. Based on ASCE 7, the potential wind speed for an  
 18 event with a 100-year recurrence interval is estimated to be 107 percent of the 50-year wind  
 19 speed or 96.3 mph.

<b>TABLE: Potential Wind Damage by Building Type</b> <i>Source: 2013 LENOWISCO HMP</i>				
Building Type	50-Year Event (90 mph)		100-Year Event (96.3 mph)	
	Building Damage	Contents Damage	Building Damage	Contents Damage
Manufactured	25%	40%	50%	100%
Light Engineered	5%	2.5%	15%	15%
Non-Engineered Wood	7.5%	5%	20%	20%
Non-Engineered Masonry	5%	2.5%	15%	15%
Fully Engineered	2.5%	2.5%	5%	15%

20  
 21



1 Vulnerability & Community Development Analysis

2 High wind events can impact the entire LENOWISCO Planning District, and accordingly, all  
 3 development should consider the impacts of a 50-year or 100-year wind event. The planning  
 4 areas in the District all have their own building codes, meaning not all cities have the same  
 5 standard building code. The vulnerability of infrastructure due to high winds is highly dependent  
 6 on construction equipment and quality. Manufactured homes are much more likely to be  
 7 damaged due to high winds. As described elsewhere in this plan, the District includes a higher  
 8 percentage of residents living in manufactured homes when compared to the national average.

<b>TABLE: Data Profile</b>			
<i>Source: American Community Survey, 2014-2018</i>			
<b>Area</b>	<b>Total Population</b>	<b>Reside in a Mobile Home</b>	<b>Houses Built Before 1939</b>
Lee County	24,134	21.9% (2,583)	11.4% (1,339)
Norton City	3,990	15.1% (309)	11.4% (233)
Scott County	22,009	25.9% (2,991)	13.5% (1,606)
Wise County	39,025	27.7% (4,976) and 0.1% (15) in a boat, RV or van	11.7% (2,096)

9 *Impact on LENOWISCO Residents*

10 Depending on the type of wind event, the damage sustained can range from extremely localized  
 11 to widespread, and from moderate to devastating. Residents may experience impacts from high  
 12 wind events including damaged and torn-off roofs; blown-out walls and garage doors;  
 13 overturned vehicles; destroyed homes and businesses; and serious injury and loss of life.

14 The LENOWISCO Planning District includes a variety of building types. Residential construction  
 15 is primarily wood framed, varying from single story to multiple stories, although some masonry  
 16 residential properties are present as well. Non-engineered wood-framed structures are among  
 17 the most susceptible to potential damage. With this type of construction being the most  
 18 prevalent for residential properties in the district, most residential structures in the area could be  
 19 classified as having a high level of vulnerability to damages should a high wind event occur.

20 While residential and commercial buildings in the District may sustain damage in a high wind  
 21 event, it will likely be minimal or moderate damage. An analysis of VDEM Region 4, the 2018  
 22 Commonwealth of Virginia HMP estimated that no households would be displaced, and no  
 23 people would be expected to seek temporary shelter in public shelters.

24





1 *Impact on Essential Facilities, Critical Infrastructure, and Future Assets*

2 The 2018 Commonwealth of Virginia HMP HAZUS-MH analysis of essential facilities in VDEM  
 3 Region 4, summarized below. The results show that all essential facilities would be available for  
 4 use or in service within one day after the high wind event.

<b>TABLE: VDEM Region 4 - 100-Year Probabilistic Wind Event, Expected Damage to Essential Facilities</b>				
<i>Source: 2018 Commonwealth of Virginia Hazard Mitigation Plan</i>				
<b>Classification</b>	<b>Total Facilities</b>	<b>Probability of at Least Moderate Damage &gt;50%</b>	<b>Probability of Complete Damage &gt;50%</b>	<b>Expected Loss of Use &lt;1 Day</b>
FOCs	2	0	0	2
Fire Stations	90	0	0	90
Hospitals	18	1	0	18
Police Stations	57	0	0	57
Schools	218	0	0	218

5  
 6 The potential impacts of a severe wind event to the District depend on the event's specific  
 7 characteristics but can include broken tree branches and uprooted trees; snapped power, cable,  
 8 and telephone lines; damaged radio, television, and communication towers. Downed trees and  
 9 power lines can fall across roadways and block key access routes, as well as cause extended  
 10 power outages to portions of the district.

11 *Impact on the Environment*

12 High winds can uproot trees and cause broken tree branches. Large scale events could impact  
 13 animals, damage farmland, and disrupt the food chain. If high winds damage power lines or  
 14 cause gas leaks, it could cause fires or contamination.

15 *Impact on Operations*

16 High winds pose the greatest impact on the distribution of gasoline or other fuels and petroleum  
 17 products, which may impact operations for organizations and businesses, in addition to back-up  
 18 power generation.

19



1 Hazard Evaluation and Impact/Consequence Assessment

Frequency & Probability <sup>1</sup>	Very Vulnerable
Potential Magnitude and Scale <sup>1</sup>	Somewhat Vulnerable
Physical Vulnerability Hazard Impact <sup>1</sup>	Vulnerable
Social Vulnerability Hazard Impact <sup>1</sup>	Vulnerable
Community Conditions Hazard Impact <sup>1</sup>	Vulnerable
Overall Capability and Capacity <sup>2</sup>	Somewhat Capable
Mitigation <sup>2</sup>	Minimally Capable
Hazard Consequence & Impact Score <sup>1</sup>	Vulnerable
Overall Risk Rating <sup>3</sup>	High

Legend			
Score	1: Vulnerability Rating	2: Capability and Capacity Rating	3: Overall Risk Rating
0 – 24	Minimally Vulnerable	Minimally Capable	Low
25 – 49	Somewhat Vulnerable	Somewhat Capable	Medium
50 – 74	Vulnerable	Capable	High
75 - 100	Very Vulnerable	Very Capable	Extreme
N/A	Not Applicable/Unknown	Not Applicable/Unknown	Not Applicable/Unknown

2  
3

DRAFT



## 1 1.6.9 Tornado

2 A tornado is a violent windstorm characterized by a twisting, funnel-shaped cloud extending to  
3 the ground. Tornadoes are most often generated by thunderstorm activity (but sometimes a  
4 result of hurricanes and other tropical systems) when cool, dry air intersects and overrides a  
5 layer of warm, moist air, forcing the warm air to rise rapidly. The damage caused by a tornado is  
6 a result of the high wind velocity and wind-blown debris. According to the National Weather  
7 Service, tornado wind speeds normally range from 40 to more than 200 miles per hour. The  
8 most violent tornadoes have rotating winds of 250 miles per hour or more and can cause  
9 extreme destruction and turning normally harmless objects into deadly missiles.

10 Tornadoes occur as part of strong thunderstorms that develop in unstable atmospheric  
11 conditions. The strongest tornadoes form with supercells, rotating thunderstorms with a well-  
12 defined radar circulation called a mesocyclone. One in three supercells experiences a descent  
13 of clouds or funnel clouds. These thunderstorms can also produce damaging hail and severe  
14 straight-line winds even without a tornado occurrence.

15 Tornadoes can range from twenty feet in width to larger than a mile on the ground and are  
16 transparent until the vortex fills with water vapor, dust, dirt, or debris. Uniquely dangerous are  
17 rain-wrapped tornadoes. If there is heavy rainfall near a tornado, a tornado can become masked  
18 or wrapped in the rainfall and become hidden.

### 19 Hazard Extent

20 Tornadoes are classified according to the Enhanced Fujita (EF) tornado intensity scale.  
21 Originally introduced in 1971, the scale was modified in 2006 to define the damage and  
22 estimated wind scale better. The Enhanced Fujita Scale ranges from low-intensity EF0 with  
23 effective wind speeds of 65 to 85 miles per hour, to EF5 tornadoes with effective wind speeds of  
24 over 200 miles per hour. The Enhanced Fujita intensity scale is included in the table below.

<b>TABLE: Enhanced Fujita (EF) Scale for Estimation of Tornado Wind Speeds</b>					
<b>Source: <a href="http://www.srh.noaa.gov/srh/jetstream/mesoscale/tornado.htm">http://www.srh.noaa.gov/srh/jetstream/mesoscale/tornado.htm</a></b>					
EF Scale	Class	Wind speed		Description	Description of Destruction
		mph	km/h		
F0	weak	65-85	105-137	Gale	Light damage, some damage to chimneys, branches are broken, signboards damaged, shallow-rooted trees blown over.
F1	weak	86-110	138-177	Moderate	Moderate damage, roof surfaces peeled off, mobile homes pushed off foundations, attached garages damaged.
F2	strong	111-135	178-217	Significant	Considerable damage, entire roofs torn from frame houses, mobile homes demolished, boxcars pushed over, large trees snapped or uprooted.
F3	strong	136-165	218-266	Severe	Severe damage, walls torn from well-constructed houses, trains overturned, most trees in forests uprooted, heavy cars are thrown about.



F4	violent	166-200	267-322	Devastating	Complete damage, well-constructed houses leveled, structures with weak foundations blown off for some distance, large missiles generated.
F5	violent	> 200	> 322	Incredible	Foundations swept clean, automobiles become missiles and thrown for 100 yards or more, steel-reinforced concrete structures badly damaged.

1

2 Historic/Previous Occurrences

3 Annually about 1,253 tornados impact the US. This number is based on the latest decade long  
 4 study which also showed that an average of 18 tornadoes impacted Virginia from 1991-2010,  
 5 with the average dropping to 0.3 EF3-EF5 tornados impacting Virginia annually. According to  
 6 the 2018 Commonwealth of Virginia Hazard Mitigation Plan (HMP), tornadoes can occur in any  
 7 month but primarily occur from April through September in Virginia. From 1950-2006, Virginia  
 8 ranked 28th in terms of the number of tornado touchdowns. Low-intensity tornadoes occur most  
 9 frequently, and tornadoes rated EF2 or higher rarely occur in Virginia ([NOAA](#)). Participating  
 10 jurisdictions in the LENOWISCO Planning District noted that they are more likely to experience  
 11 straight-line winds than tornado events.

12 **FIGURE: Tornado Annual Averages by State (1991–2010 averaging period)**

13 **Source: [NOAA](#)**

Average Annual Number of Tornadoes

Averaging Period: 1991–2010

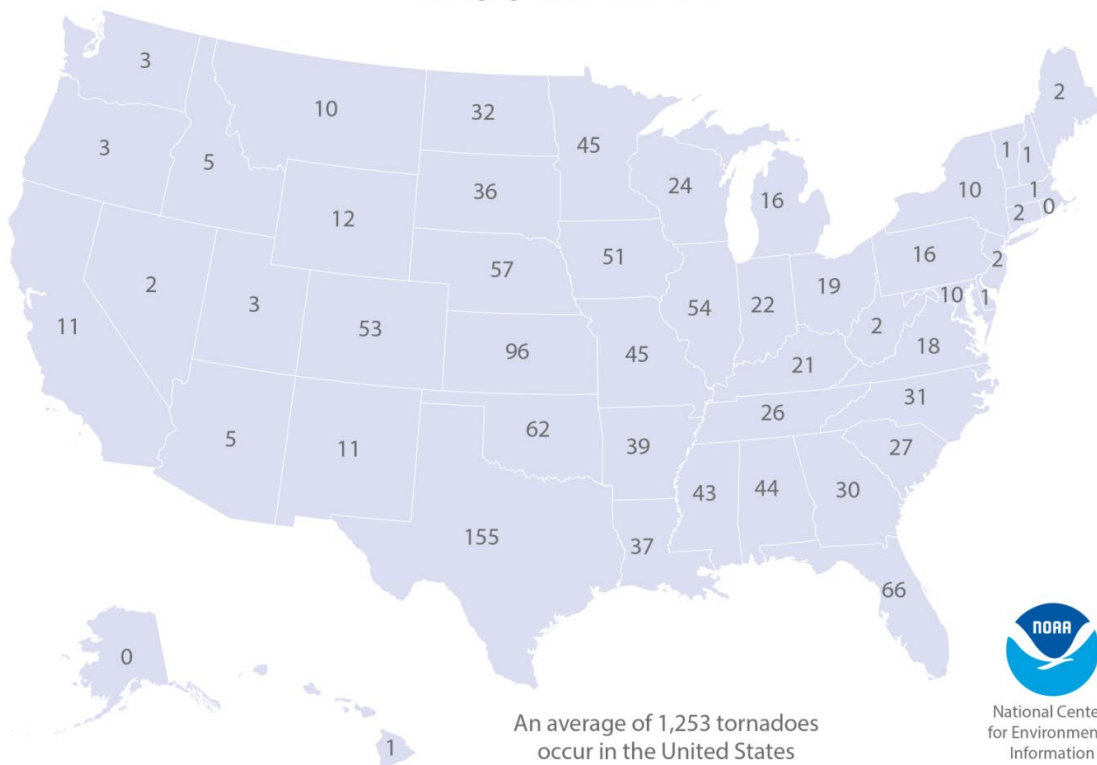

An average of 1,253 tornadoes occur in the United States each year



14



1 During the analysis timeframe (2015-2020) for the HMP update, no tornados or funnel cloud events were recorded as impacting the  
 2 area. Expanding the search to 10 years, three events were recorded in the National Oceanic and Atmospheric Administration  
 3 (NOAA) National Centers for Environmental Information (NCEI) Database.

**TABLE: Tornado and Funnel Cloud Events from 01/01/2010 to 12/31/2020**  
**Source: NOAA National Centers for Environmental Information Storm Events Database**

Jurisdiction	Event Type	Dates of Occurrence	Direct Deaths	Direct Injuries	Reported Property Damage	Reported Crop Damage	Indirect Deaths	Indirect Injuries
City of Norton	Tornado - EF0	04/09/2011	0	0	\$50,000	0	0	0
Lee County	Tornado - EF1	3/2/2012	0	1	\$1,750,000	0	0	0
Town of Coeburn	Funnel Cloud	2/29/2012	0	0	\$0	0	0	0

4  
 5 **Event Details:**

- 6 • **April 9, 2011:** Boundary across the area triggered scatter severe thunderstorms during the afternoon and evening hours on  
 7 the 9th. Storm reports were for both large hail and damaging thunderstorm winds. An EF-0 tornado with maximum winds at  
 8 80 mph, downed several trees and moderately damaged two old buildings in Norton, Virginia. The damage to the buildings  
 9 consisted of a partial roof and wall collapsed along with a chimney collapsing.
- 10 • **March 2, 2012:** A deepening low-pressure system moved northeast from the Mid-Mississippi Valley through the Great Lakes  
 11 and drove a warm front northward through the Southern Appalachian region during the afternoon, and an associated cold  
 12 front swept across the area late Friday night. A total of three tornadoes, ranging in intensity from EF-0 to EF-1, were produced  
 13 by the storm. One EF1 tornado with maximum winds at 110 mph started in Claiborne County, TN, and moved northeast into  
 14 Lee County. The tornado destroyed two houses and damaged four additional houses in Lee County. Additionally, about 20  
 15 barns and outbuildings were damaged or destroyed along with miles of agricultural fence line being damaged or destroyed.  
 16 The tornado path was roughly five miles and downed many trees along the path from Claiborne to Lee County. Residential  
 17 losses total roughly \$350,000, and agricultural property losses totaled approximately \$1.3 million.
- 18 • **Other Events:** Expanding the event search to include "hail," 25 hail events have been recorded as impacting LENOWISCO  
 19 from 01/01/2010 to 12/31/2020. Two of the hail events were associated with supercell thunderstorms that generated  
 20 tornados. Supercell thunderstorms can span large areas, and of these two events, only one produced tornado in the  
 21 LENOWISCO region; the other produced tornados in Monroe County, Tennessee. The hail event that produced a tornado in  
 22 LENOWISCO was the same event also recorded under the "tornado" category on 3/2/2012.





1 Future Probability

2 Based on the Community Vulnerability Risk and Resiliency (CVR2) assessment, detailed in Section 1.6.13 (methodology) and  
 3 Section 1.6.14 (results), this hazard is **Somewhat Probable/Somewhat Frequent** because significant occurrences of this hazard  
 4 have happened on occasion (even though isolated or low impact events may occur with more regularity). The overall risk ranking for  
 5 this hazard is **Medium**.

6 The 2018 Commonwealth of Virginia Hazard Mitigation Plan (HMP) outlines a ranking of each jurisdiction in the LENOWISCO  
 7 Planning District based on various risk factors. Nowhere in the District was ranked as "higher" risk for a tornado in the 2018 HMP  
 8 given the southeastern and northern part of the Commonwealth have significantly higher tornado occurrences. The 2018 HMP  
 9 analysis is included in the table below.

**TABLE: Tornado Hazard Ranking Parameters**  
 Source: Commonwealth of Virginia Hazard Mitigation Plan (HMP), 2018

Jurisdiction Name	Population Vulnerability	Population Density	Injuries & Fatalities	Property Damage	Crop Damage	Events	Geographic Extent	Total Risk Ranking
Lee County	Medium	Low	Low	High	Low	Medium	Medium	Medium-Low
City of Norton	Low	Medium-High	Low	Low	Low	Low	Low	Low
Scott County	Medium	Low	Low	Low	Low	Medium-Low	Medium-Low	Low
Wise County	Medium	Medium	Low	High	Low	Medium-Low	Medium-Low	Medium-Low

10



1 Geographic Location

2 The LENOWISCO Planning District is uniformly at risk of tornado events. According to the 2018  
3 Virginia HMP, the three counties making up the LENOWISCO Planning District have a low or  
4 medium-low frequency of tornado events since 2016. According to the HMP, low-intensity  
5 tornadoes tend to be more frequently reported in higher population areas. There have been  
6 several, low-intensity tornadoes reported since 1955 in the District, as illustrated in the map  
7 below. The most intense tornado event in the District on record was an EF-2 event in northeast  
8 Wise County, between Pound and Wise.

9 **FIGURE: Historic Tornado Events in the LENOWISCO Planning District**

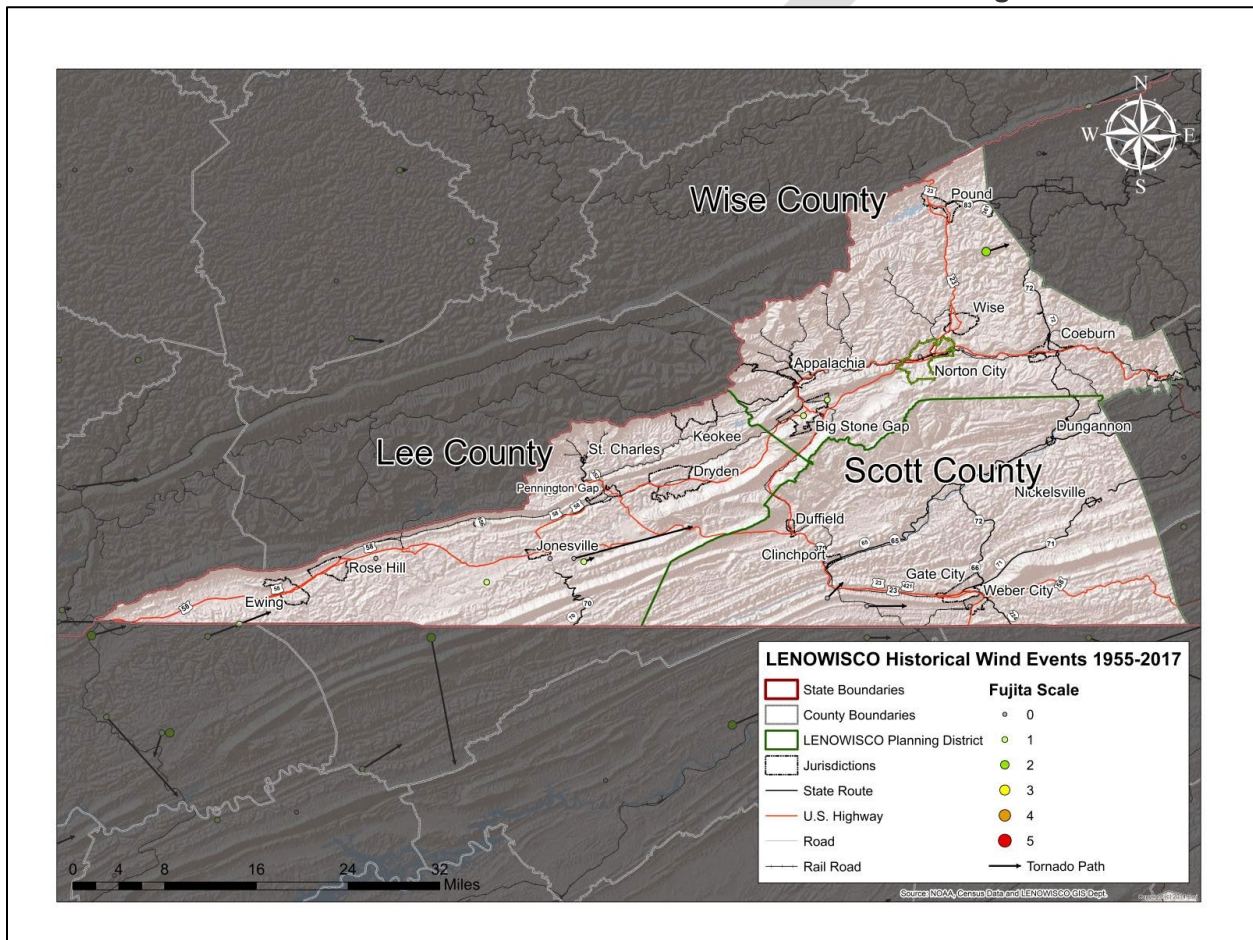

10

11 Loss Estimates

12 Due to the low number of historic tornado events in the LENOWISCO Planning District, as  
13 documented in the NOAA NCEI Storm Events Data, there is not currently a reliable method to  
14 calculate annualized losses.



1 Vulnerability and Community Development Analysis

2 Since tornadoes can occur in any area, the entire population and all buildings are vulnerable to  
 3 tornadoes. To accommodate this risk, this plan will consider all buildings within the  
 4 LENOWISCO Planning District as vulnerable.

5 The planning areas in the District all have their own building codes, meaning not all cities have  
 6 the same standard building code. The vulnerability of infrastructure due to a tornado is highly  
 7 dependent on construction equipment and quality. Low-intensity tornados, below an EF2, will  
 8 likely not impact a well-constructed building. However, the tornado that impacted Lee County in  
 9 2012 was below an EF2 and produced extensive residential and agricultural damage.

10 *Impact on Residents*

11 A tornado would affect an entire population in the tornado's path most severely, but power  
 12 outages and street closures have the potential to impact many more. Those most at risk from  
 13 tornadoes include people living in mobile homes, campgrounds, and other dwellings without  
 14 secure foundations or basements. People in automobiles are also very vulnerable to tornadoes.  
 15 The elderly, very young, and the physically and developmentally disabled are particularly  
 16 vulnerable when they have a lack of mobility to escape the path of destruction.

17 The table below highlights the statistics of the population most vulnerable to tornadoes.  
 18 The [2014—2018 ACS 5-Year Data and Narrative Profiles](#) for City of Norton, Lee County, Scott  
 19 County, and Wise County provide insights on the percentage and number of population  
 20 members that are more susceptible to tornado impact. The Annexes to the plan further provide  
 21 a breakdown of vulnerabilities within each community in the LENOWISCO Planning District.

**TABLE: Data Profile**  
**Source: American Community Survey, 2014-2018**

Area	Total Population	Disabled	Individuals in Poverty	Individuals Over 65 years old	Speak English "less than very well"
City of Norton	3,990	23.6% (929)	29.4%	14.2% (689)	0%
Lee County	24,134	25.9% (5,859)	24%	19.7 % (4,759)	0.6% (139)
Scott County	22,009	24.8% (5,286)	18.6%	22.7% (4,999)	0.6% (123)
Wise County	39,025	26.9% (9886)	22%	16.9% (6,583)	0.5% (191)

22  
 23 People who may not understand watches and warnings due to language barriers are also at  
 24 risk. While less than 1% of the population in each area was recorded as speaking English "less  
 25 than very well," communication accommodations need to be made to ensure the entire  
 26 population understands tornado watches and warnings.

27 Individuals over 65 years old and those with a disability may have limited mobility that prevents  
 28 them from seeking safe shelter from a tornado. An average of 18.38% of the population is over  
 29 65 years old in the District. The area has a higher disabled population than most of the United



1 States, with an average of 25.3% individuals having at least one disability in the District versus  
2 12.6% for the entire United States.

3 Individuals lacking the resources, such as those living at or below the poverty level, will  
4 experience disproportionate challenges to recovering from a tornado. In LENOWISCO, a little  
5 less than half of the population is living at or below the poverty line (23.5%). The average in the  
6 District is considerably higher than the national average of 14.1%.

7 Another vulnerable population is people that are experiencing homelessness. While exact data  
8 is not available on the number of residents in the District that are experiencing homelessness,  
9 the [National Alliance to End Homelessness](#) includes LENOWISCO in a much larger planning  
10 area that shows that 4.2 people of every 10,000 will experience homelessness. The 2018 ACS  
11 population data indicates that approximately 89,158 reside in the District. Using this data and  
12 assuming all areas grouped by the National Alliance to End Homelessness experienced similar  
13 trends, approximately nine people in the LENOWISCO Planning District would experience  
14 homelessness on any given night.

15 **MAP: Virginia Homeless Statistics**

16 **Source: [Virginia Data for National Alliance to End Homelessness](#)**

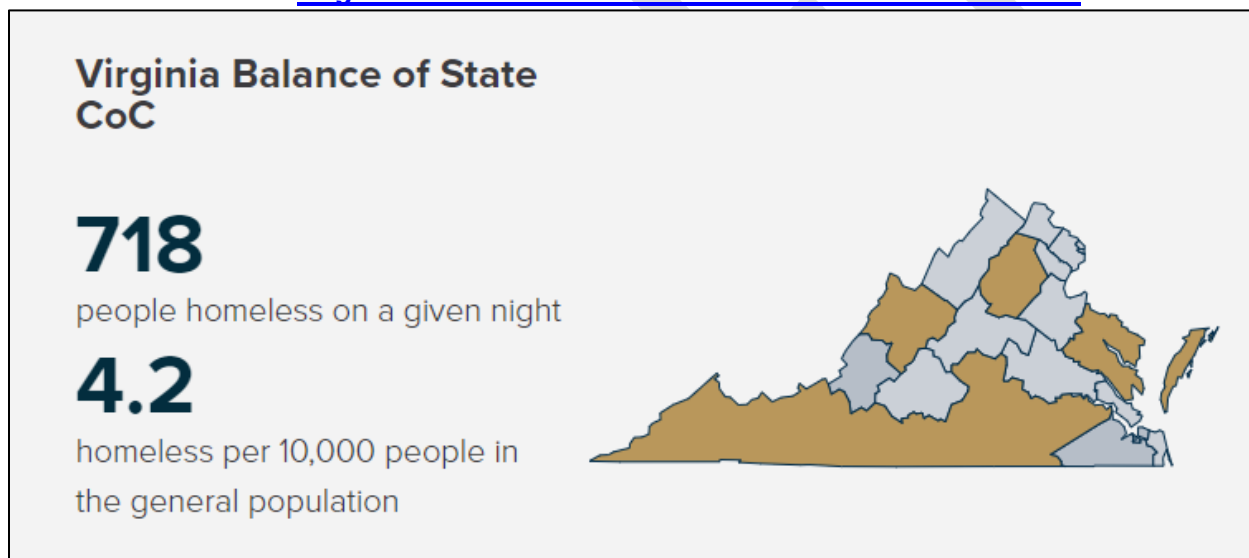

17  
18 *(areas on the map in brown are factored into the dataset)*

19 ***Impact on Essential Facilities, Critical Infrastructure, and Future Assets***

20 All essential facilities are vulnerable to tornadoes. An essential facility will encounter many of  
21 the same impacts as any other building within the jurisdiction. These impacts will vary based on  
22 the magnitude of the tornado but can include structural failure, debris damage, roofs blown off,  
23 high winds, and loss of facility functionality (e.g., damaged police station impacts service to the  
24 community). Further damage can be caused if tornadoes are accompanied by heavy rain  
25 resulting in flooding (flash).

26 During a tornado, the types of infrastructure that could be impacted include roadways, utility  
27 lines/pipes, railroads, and bridges. The impacts on these structures include broken, failed, or  
28 impassable roadways, broken or failed utility lines (e.g., loss of power or gas to the community),





1 and railway failure from broken or impassable railways. Bridges could fail or become  
 2 impassable, causing a risk to traffic.

3 Since tornados can occur anywhere in the county, any future development will have to be made  
 4 with this hazard in mind. Mobile home parks, campgrounds, or any other facility without a  
 5 secure foundation or basement will always be particularly vulnerable.

6 In the LENOWISCO Planning District, the percentage of residents residing in mobile homes is  
 7 much higher than the national percentage. In the United States, 6.2% of housing units are  
 8 mobile homes. In the District, the average percentage of housing units that are mobile homes  
 9 between the three counties and the City of Norton is 22.65%. The residents in mobile homes, as  
 10 well as the ones living in a boat, RV, or van, are particularly susceptible to tornado damage.

11 An additional consideration is the changes in building codes that have stabilized newer  
 12 developments for hazard impacts. The table below includes homes that were built before 1939,  
 13 and thus after building code changes.

<b>TABLE: Data Profile</b>			
<b>Source: American Community Survey, 2014-2018</b>			
<b>Area</b>	<b>Total Population</b>	<b>Reside in a Mobile Home</b>	<b>Houses Built Before 1939</b>
Lee County	24,134	21.9% (2,583)	11.4% (1,339)
Norton City	3,990	15.1% (309)	11.4% (233)
Scott County	22,009	25.9% (2,991)	13.5% (1,606)
Wise County	39,025	27.7% (4,976) and 0.1% (15) in a boat, RV or van	11.7% (2,096)

14 ***Impact on the Environment***

15 Tornados can destroy trees, buildings, and other important infrastructure. Tornados have been  
 16 known to kill animals, damage farmland, and disrupt the food chain. Tornados can also cause  
 17 water contamination, impacting local flora and fauna, not to mention humans. If a tornado hits  
 18 power lines or causes gas leaks, fires or contamination can also result.

19 ***Impact on Operations***

20 Vulnerabilities associated with tornadoes include any staff active during the initial impact of a  
 21 tornado. All personnel in vehicles are particularly vulnerable during a tornado. Should a tornado  
 22 make roads impassable or disable communication lines, breakdowns or delays in all potential  
 23 operations are possible. Private or public urban tree removal services are also vulnerable to  
 24 tornadoes.

25





1 Hazard Evaluation and Impact/Consequence Assessment

Frequency & Probability <sup>1</sup>	Somewhat Vulnerable		
Potential Magnitude and Scale <sup>1</sup>	Somewhat Vulnerable		
Physical Vulnerability Hazard Impact <sup>1</sup>	Vulnerable		
Social Vulnerability Hazard Impact <sup>1</sup>	Vulnerable		
Community Conditions Hazard Impact <sup>1</sup>	Vulnerable		
Overall Capability and Capacity <sup>2</sup>	Vulnerable		
Mitigation <sup>2</sup>	Somewhat Capable		
Hazard Consequence & Impact Score <sup>1</sup>	Minimally Capable		
Overall Risk Rating <sup>3</sup>	Medium		
Legend			
Score	1: Vulnerability Rating	2: Capability and Capacity Rating	3: Overall Risk Rating
0 – 24	Minimally Vulnerable	Minimally Capable	Low
25 – 49	Somewhat Vulnerable	Somewhat Capable	Medium
50 – 74	Vulnerable	Capable	High
75 - 100	Very Vulnerable	Very Capable	Extreme
N/A	Not Applicable/Unknown	Not Applicable/Unknown	Not Applicable/Unknown

2

3

DRAFT



## 1 **1.6.10 Wildfire**

2 Wildfire is defined by the USDA Forest Service as a fire, naturally caused or caused by humans,  
3 that is not meeting land management objectives ([U.S. Forest Service](#)). Wildfires, especially  
4 those in or near developed areas, can pose a significant threat to life and property. Wildfires in  
5 Virginia are typically human-caused incidents but can be exacerbated by drought  
6 conditions. Fire season in Virginia is considered to be spring (March and April) and fall (October  
7 and November).

8 Three important factors determine the formation of wildfires: weather, fuel, and topography.

- 9 • **Weather:** drought or long dry periods, low humidity, and windy conditions can  
10 contribute to an increased chance of wildfire ignition, as well as increase speed and  
11 intensity of the burn.
- 12 • **Fuel:** dry and low-humidity conditions cause fuels on the forest floor to dry out,  
13 including grasses, conifer needles, leaves, and small twigs or brush. Long dry periods  
14 can result in risk from even larger fuels.
- 15 • **Topography:** Wildfire events impact the stabilization of the soil by removing  
16 groundcover and vegetation. Decreased soil stability, an increased risk in areas with  
17 steep topography, can result in landslides, flooding, and erosion for years after a fire.

### 18 Hazard Extent

19 Geographic extent for the Wildfire hazard is defined as the percent of the jurisdiction that falls  
20 within a "high" risk according to the Virginia Department of Forestry Risk Assessment.  
21 According to the 2018 Commonwealth of Virginia Hazard Mitigation Plan (HMP), the geographic  
22 extent for wildfire is "low" in all jurisdictions in the LENOWISCO Planning District, meaning less  
23 than 10% of the jurisdiction has a "high" risk of wildfire events. According to the HMP, the  
24 wildfire cannot be easily expressed in specific recurrence intervals as with other hazard events.

### 25 Historic/Previous Occurrences

26 Scott County was included in a federal disaster declaration for wildfire, according to the 2018  
27 Commonwealth of Virginia Hazard Mitigation Plan (HMP). Planning committee participants  
28 noted that small wildfire events occur annually on the U.S. Forest Service and National Park  
29 Service land within the LENOWISCO Planning District. These wildfires have not resulted in  
30 residential property damages to date.

31 The [Federal Fire Occurrence Database](#) tracks wildfire events on federal lands between 1980-  
32 2016. Between 2000-2016, there was one Class F (300-1,000 acres) fire reported in the District,  
33 to the northeast of Dungannon at the edge of Scott and Wise counties. This fire was on U.S.  
34 Forest Service land. There were 38 Class B and C fires (up to 100 acres) on U.S. Forest  
35 Service land or National Park Service Land in the same timeframe.



- 1 Future Probability
- 2 Based on the Community Vulnerability Risk and Resiliency (CVR2) assessment, detailed in Section 1.6.13 (methodology) and
- 3 Section 1.6.14 (results), this hazard is **Probable/Frequent** because occurrences of this hazard have happened regularly (even
- 4 though isolated or low impact events may occur with more regularity). The overall risk ranking for this hazard is **High**.
- 5 All the jurisdictions in the LENOWISCO Planning District are at "low" risk to wildfire hazards, according to the 2018 Virginia HMP
- 6 ranking parameters included in the table below. As wildfires are heavily influenced by changing weather conditions and human
- 7 activities, there is no quantitative assessment of future probability available at a regional level in Virginia. According to the Virginia
- 8 Department of Forestry (VDOF) Wildfire Risk Assessment, the Commonwealth experiences an average of 1,000 wildfires annually,
- 9 burning 11,000 acres.

**TABLE: Wildfire Hazard Ranking Parameters**  
*Source: 2018 Commonwealth of Virginia Hazard Mitigation Plan*

Jurisdiction	Population Vulnerability	Population Density	Injuries & Fatalities	Property Damage	Crop Damage	Events	Geographic Extent	Total Risk Ranking
City of Norton	Low	Medium-High	Low	Low	Low	Low	Low	Low
Lee County	Medium	Low	Low	Low	Low	Low	Low	Low
Scott County	Medium	Low	Low	Low	Low	Low	Low	Low
Wise County	Medium	Medium	Low	Low	Low	Low	Low	Low

10



1 Geographic Location

2 Areas of Virginia at risk to wildfire events are illustrated in the VDOF Wildfire Risk Assessment  
3 below, categorized as either low risk, moderate risk, or high risk. This map depicts the potential  
4 for wildfire based on several factors, including Slope, Aspect, Landcover, Distance to Railroads,  
5 Distance to Roads, Population Density, and Historical Fire Occurrence. Much of the  
6 LENOWISCO Planning District is "high risk" based on this assessment. VDOF is in the process  
7 of updating this risk assessment as a part of a wildfire mitigation project focused on the  
8 wildland-urban interface (WUI).

9 **FIGURE: Virginia Wildfire Risk Assessment**

10 **Source: [Virginia Department of Forestry](#)**

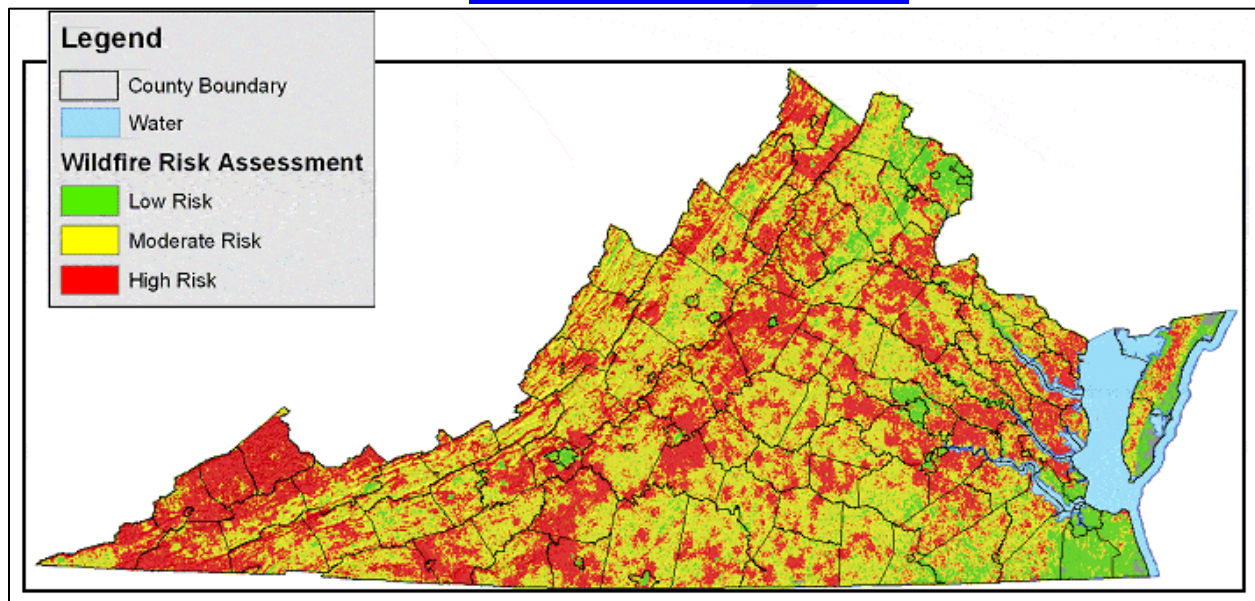

11  
12 The U.S. Forest Service manages an interactive website that illustrates wildfire risk to  
13 communities across the country. A map of the "risk to homes" LENOWISCO Planning District is  
14 included below. According to this tool map, the LENOWISCO Planning District and  
15 southwestern Virginia as a whole have the greatest areas of risk in the state. Specifically,  
16 sections of Wise County along U.S. Highway 23 between Big Stone Gap and Norton, and south  
17 of Pound, have very high risk.

18



1  
2

**FIGURE: Wildfire Risk to Communities - Risk to Homes**  
**Source: [U.S. Forest Service](#)**

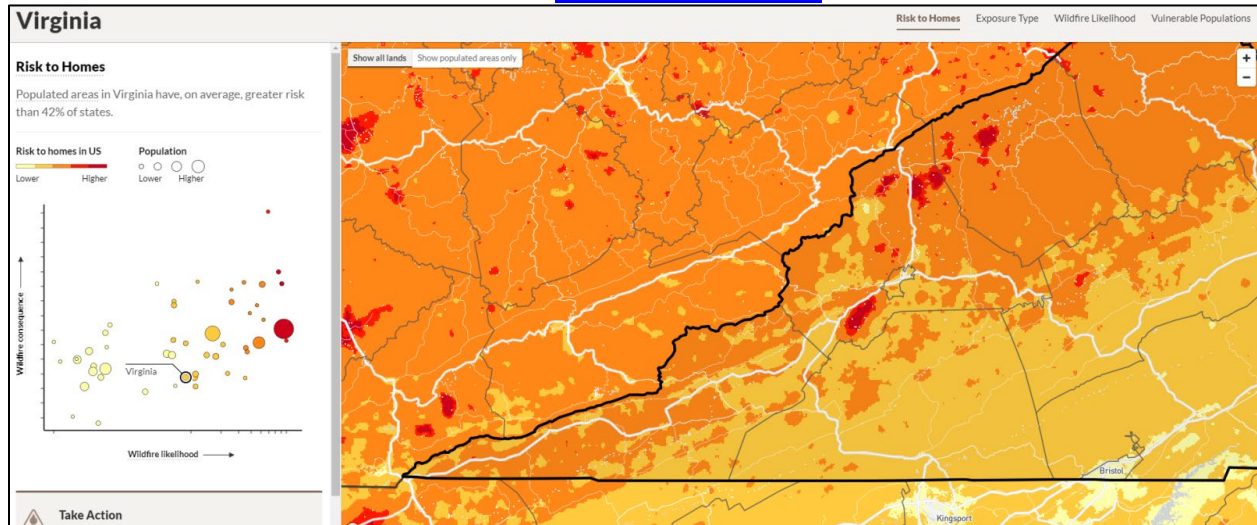

3

#### 4 Loss Estimates

5 Due to the lack of wildfire events recorded in the NCEI Storm Events Database, it is difficult to  
6 accurately estimate annualized losses due to wildfire events. VDOF estimated \$2 million in  
7 annualized damages for the Commonwealth of Virginia in 2014-2015, inclusive of damages to  
8 timber, structures, and personal property.

#### 9 Vulnerability and Community Development Analysis

10 New homes and development are increasingly located in the wildland-urban interface (WUI).  
11 WUI is the area where structures and other human development meet or intermingle with  
12 developed wildland. Expansion of the WUI poses significant challenges to wildfire management  
13 and impact, as it represents environments where forest and grassland fires can move quickly  
14 into neighborhoods. Portions of the LENOWISCO Planning District, across all three counties,  
15 include residential structures located in the WUI, as shown in the maps on the following pages.

16











1

**FIGURE: Wise County Wildland-Urban Interface**

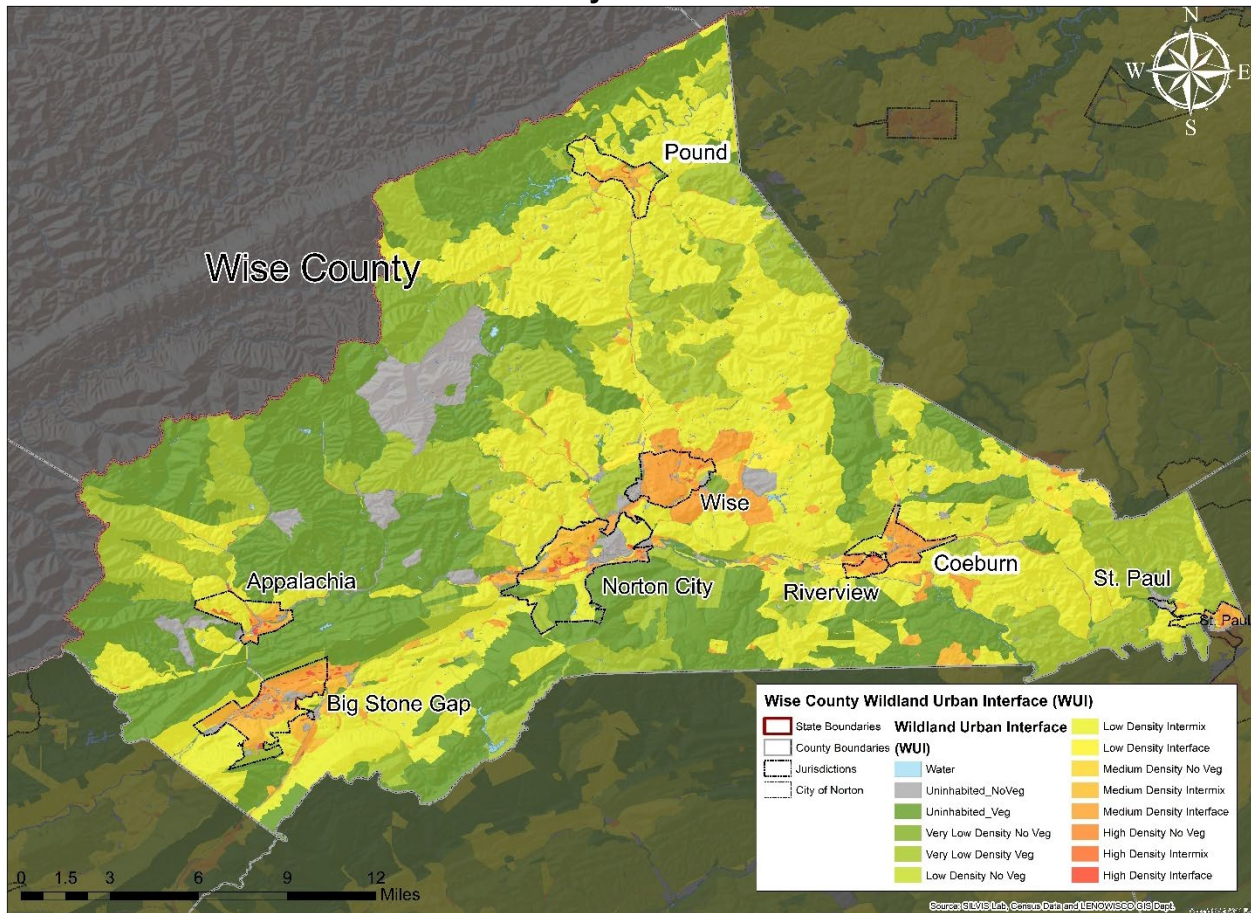

2

3 The leading cause of wildfire events in Virginia is debris burning, followed by arson. Human  
 4 activities cause most wildfire events in the Commonwealth, with only 4% of fires caused by  
 5 lightning strikes. As human and wildland interactions increase, as is the case with suburban  
 6 development patterns, it is likely that the incidence of wildfire events in Virginia will grow.

7



1  
2

**FIGURE: Virginia Wildfire Causes from 1995-2016**  
**Source: [2018 Commonwealth of Virginia Hazard Mitigation Plan \(HMP\)](#)**

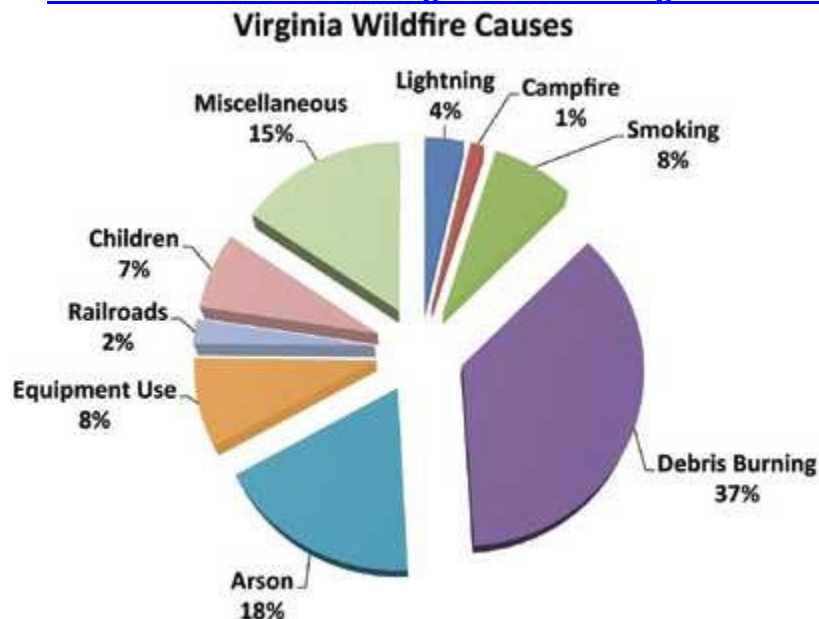

3

#### 4 *Impact on LENOWISCO Residents*

5 Residents may be at risk to evacuation notices for larger wildfire events, and increasingly to  
6 smoke impacts from nearby fires. The 2020 historic wildfire season in the western United States  
7 resulted in smoke and degraded air quality across the country. Smoke from fires and the  
8 resulting poor air quality poses greater threats to those with underlying health conditions and the  
9 elderly.

#### 10 *Impact on Essential Facilities, Critical Infrastructure, and Future Assets*

11 The vulnerability of property to wildfire is influenced by surrounding land cover and land  
12 management techniques. Urban areas are less vulnerable to wildfire, but suburban areas or  
13 those in the WUI are more vulnerable. Individual properties and buildings will be more  
14 vulnerable based on the clear distance around the structure and construction materials.

#### 15 *Impact on the Environment*

16 Wildfires can have significant effects on the environment, including the destruction of trees and  
17 vegetation, and increased erosion or landslide risks that may threaten water quality. Wildfire can  
18 also allow some vegetation to flourish due to increased sunlight exposure at the ground level.

#### 19 *Impact on Operations*

20 In Virginia, most wildfire response is handled at the local level. Fire events require the attention  
21 of local fire districts and would impact their operations. Wildfire could potentially impact major  
22 roads depending on the extent and location.



1 Hazard Evaluation and Impact/Consequence Assessment

Frequency & Probability <sup>1</sup>	Vulnerable
Potential Magnitude and Scale <sup>1</sup>	Minimally Vulnerable
Physical Vulnerability Hazard Impact <sup>1</sup>	Vulnerable
Social Vulnerability Hazard Impact <sup>1</sup>	Vulnerable
Community Conditions Hazard Impact <sup>1</sup>	Vulnerable
Overall Capability and Capacity <sup>2</sup>	Somewhat Capable
Mitigation <sup>2</sup>	Minimally Capable
Hazard Consequence & Impact Score <sup>1</sup>	Vulnerable
Overall Risk Rating <sup>3</sup>	High

Legend			
Score	1: Vulnerability Rating	2: Capability and Capacity Rating	3: Overall Risk Rating
0 – 24	Minimally Vulnerable	Minimally Capable	Low
25 – 49	Somewhat Vulnerable	Somewhat Capable	Medium
50 – 74	Vulnerable	Capable	High
75 - 100	Very Vulnerable	Very Capable	Extreme
N/A	Not Applicable/Unknown	Not Applicable/Unknown	Not Applicable/Unknown

2  
3

DRAFT





## 1 1.6.11 Winter Storm

2 The National Weather Service ([NWS](#)) describes winter storms as weather conditions that  
3 produce heavy snow or significant ice accumulations. The National Severe Storms Laboratory  
4 ([NSSL](#)), a part of the National Oceanic and Atmospheric Administration (NOAA), defines a  
5 winter storm as a type of winter weather and an event in which the main types of precipitation  
6 are snow, sleet, or freezing rain. A winter storm is a combination of heavy snow, blowing snow,  
7 and/or dangerous wind chills. Severe winter weather refers to winter storm events including  
8 blizzards and ice storms. These hazards can happen independently of one another or at the  
9 same time. Winter weather hazard events occur when an excessive amount of snowfall or other  
10 related winter weather, such as severe ice storms, high winds, and cold temperatures affect  
11 residents' safety, transportation, and ability to work and deliver goods.

12 Typically, winter storms form from a combination of **cold air** (below freezing temperatures in the  
13 clouds and near the ground), **lift** (raise the moist air to form clouds causing precipitation),  
14 and **moisture** (used to form clouds and perceptions). The combination is essential to create a  
15 winter storm.

16 Severe winter weather consists of various forms of precipitation and strong weather conditions.  
17 This may include one or more of the following: freezing rain, sleet, heavy snow, blizzards, icy  
18 roadways, extremely low temperatures, and strong winds. The most common winter weather  
19 events in southwestern Virginia include:

- 20 • **Ice Storms:** Ice storms are one of the most dangerous types of winter storms and  
21 typically occur when precipitation falls from above freezing (32 degrees Fahrenheit)  
22 temperatures and comes in contact with air or surfaces that are below freezing. During  
23 ice storms, ice accumulates on the ground surfaces, power lines, and trees. Ice causes  
24 dangerous conditions on the ground, reducing traction and rendering slick surfaces.
- 25 • **Blizzards and Snowstorms:** Significant snowstorms are characterized by the rapid  
26 accumulation of snow, often accompanied by high winds, cold temperatures, and low  
27 visibility. Severe winter weather also occurs in the form of blizzards and heavy snow. A  
28 blizzard is characterized by periods of heavy snow and high winds (at least 35 miles per  
29 hour) lasting more than 3 hours. Visibility is decreased to less than a quarter of a mile.  
30 Although extreme cold often accompanies blizzard conditions, a blizzard does not  
31 necessarily have to occur in extremely cold conditions. Heavy snow is classified as snow  
32 accumulations expected to approach or exceed six inches in 12 hours or eight inches in  
33 24 hours. Heavy snow is not necessarily accompanied by significant wind, freezing rain,  
34 or sleet.
- 35 • **Snow:** Most precipitation that forms in wintertime clouds starts out as snow. The top  
36 layer of the storm is usually cold enough to create snowflakes.
- 37 • **Sleet:** Sleet occurs when snowflakes only partially melt, and they fall through a shallow  
38 layer of warm air.
- 39 • **Freezing Rain:** Freezing rain occurs when snowflakes descend into a warmer layer of  
40 air and melt completely.

41



1  
2

**FIGURE: Snow Formation**  
Source: [NOAA](#)

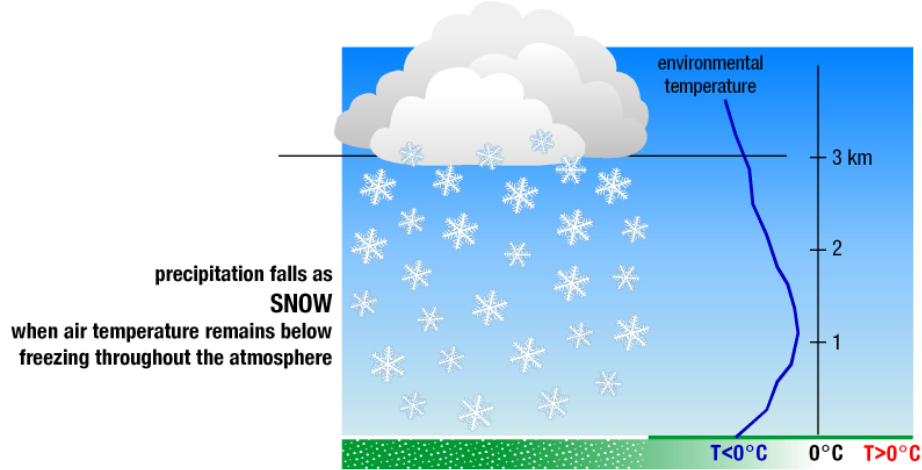

3  
4  
5

**FIGURE: Sleet Formation**  
Source: [NOAA](#)

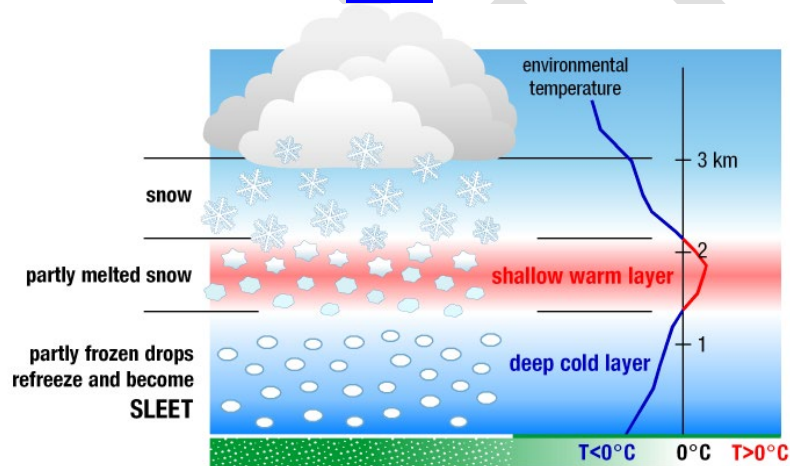

6  
7  
8

**FIGURE: Freezing Rain**  
Source: [NOAA](#)

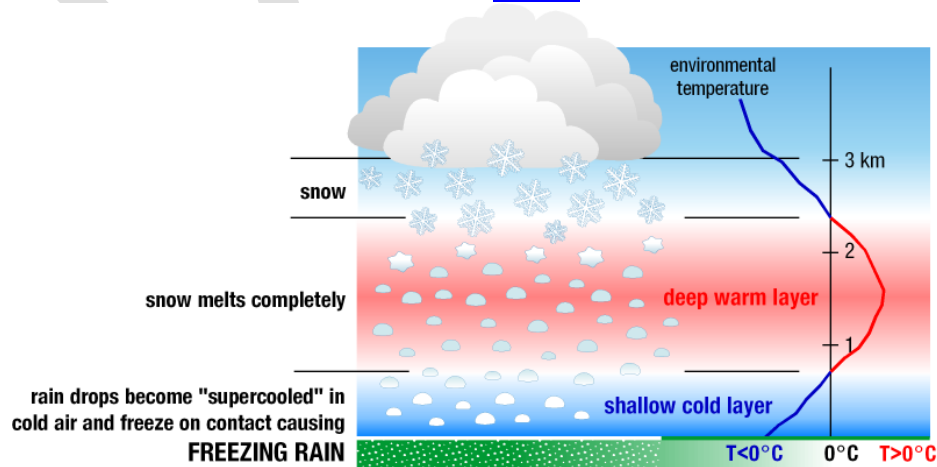

9



## 1 Hazard Extent

2 The National Weather Service provides a classification system for various types of winter storm  
3 events. Severe winter weather can often be forecasted a few days in advance, allowing more  
4 time to prepare life and safety measures, notify residents, and position resources. National  
5 Weather Service definitions include:

- 6 • **Winter Storm Watch:** Issued when there is a potential for heavy snow or significant ice  
7 accumulations, usually 24 to 36 hours in advance.
- 8 • **Winter Storm Warning for Snow:** Issued for winter storms producing at least 6 inches  
9 of snow in a 12-hour period or at least 8 inches of snow in a 24 hour period.
- 10 • **Winter Storm Warning for Sleet:** Issued by the National Weather Service for winter  
11 storms producing at least a half ( $\frac{1}{2}$ ) inch of sleet.
- 12 • **Blizzard Warning:** Issued for winter storms with sustained or frequent winds of 35 mph  
13 or higher with considerable falling and/or blowing snow that frequently reduces visibility  
14 to a quarter ( $\frac{1}{4}$ ) mile or less. These conditions are expected to prevail for a minimum of  
15 3 hours.
- 16 • **Ice Storm Warning:** Issued when freezing rain produces more than a quarter ( $\frac{1}{4}$ ) inch  
17 accumulation of ice.
- 18 • **Winter Weather Advisory for Snow and Blowing Snow:** Issued for winter storms with  
19 25-34 mph winds and blowing snow that frequently reduces visibility to a quarter ( $\frac{1}{4}$ )  
20 mile or less.
- 21 • **Winter Weather Advisory for Snow:** Issued for winter storms producing 3 to 5 inches  
22 of snow. Occasionally will be issued for winter storms producing 2 to 4 inches of snow.
- 23 • **Winter Weather Advisory for Sleet:** Issued for winter storms producing less than a half  
24 ( $\frac{1}{2}$ ) inch of sleet



1 History/Previous Occurrences

- 2 During the analysis timeframe (2015-2020) for the HMP update, 12 events were recorded in the NOAA National Centers for  
 3 Environmental Information (NCEI) Database. The majority of the events impacted multiple areas in LENOWISCO.

**TABLE: Blizzard, Heavy Snow, and Ice Storm Events in LENOWISCO from 01/01/2015 to 08/01/2020**  
**Source: NOAA National Centers for Environmental Information Storm Events Database**

County	Event Type	Dates of Occurrence	Direct Deaths	Direct Injuries	Reported Property Damage	Reported Crop Damage	Indirect Deaths	Indirect Injuries
Lee	Heavy Snow	2/17/2015	0	0	0	0	0	0
		2/21/2015						
		1/20/2016						
		1/22/2016						
Scott	Heavy Snow	2/16/2015	0	0	0	0	0	0
		2/21/2015						
		1/20/2016						
Wise	Heavy Snow	2/14/2016	0	0	0	0	0	0
		1/22/2016						
		2/8/2016						
		2/14/2016						
		1/6/2017						
		3/12/2018						
		12/9/2018						
		2/16/2015						
		2/17/2015						
		2/21/2015						
2/26/2015								
Ice Storm	Ice Storm	2/16/2015	0	0	0	0	0	0
		3/4/2015						



1 Other major events in the LENOWISCO Planning District, prior to 2015, include:

- 2 • **January 20-22, 1985:** an arctic cold front swept across the state.
- 3 New temperature records were set at several locations, and fresh
- 4 snow helped wind chill temperatures plunge well below zero.
- 5 • **Winter 1993-1994:** Virginia was struck by a series of ice storms.
- 6 Although ice storms are not an uncommon event in the valleys and
- 7 foothills of the Appalachian Mountains, and the region had been
- 8 overdue for an ice storm, it was unprecedented to have several
- 9 occur in succession.
- 10 • **March 12-15, 1993:** The “Super Storm of March ‘93” or “The Storm
- 11 of the Century” affected 26 eastern and central states and resulted
- 12 in a federal disaster declaration. Snowfall across the region ranged
- 13 from 12 to 48 inches depending on elevation. Far southwestern Virginia saw 30 to 42 inches of snow, the most in more than
- 14 25 years. Winds produced blizzard conditions with snowdrifts up to 12 feet. Interstates were shut down. Shelters were opened
- 15 for 4,000 stranded travelers. The Virginia National Guard helped with emergency transports and critical snow removal.
- 16 • **February 10-11, 1994:** an ice storm caused some areas of southern Virginia to receive up to three inches of ice, causing
- 17 tremendous tree damage and power outages for up to a week.
- 18 • **January 6, 1996:** The “Blizzard of ‘96” or “Great Furlough Storm” contributed to as much as 30 to 36 inches of snow over the
- 19 western mountains.
- 20 • **December 2009:** A week before Christmas, a Nor’easter slammed the East Coast, breaking records for a December snowfall.
- 21 Thousands were left without power, some for several days, in the biggest snowstorm to affect western Virginia since the
- 22 January 1996 storm.
- 23 • **October 2012:** Many snowstorms affecting the LENOWISCO district follow familiar storm tracks, but Hurricane Sandy
- 24 brought an unusual mix of weather conditions to the Eastern seaboard. Wise County saw as much as 10 inches of snow,
- 25 while much of Lee County had a minor dusting.

TABLE: Historic Snowfall Amounts	
Source: 2013 LENOWISCO Hazard Mitigation Plan	
Date	Amount
February 12 - March 10, 1960	65 inches
December 10-12, 1960	4-13 inches
January 20-22, 1985	4 inches
March 13-14, 1993	30-42 inches
January 6-13, 1996	30-36 inches
January 27-28, 1998	12-24 inches
December 18-20, 2009	8-12 inches
October 30-31, 2012	6-10 inches





1 Future Probability

2 Based on the Community Vulnerability Risk and Resiliency (CVR2) assessment, detailed in Section 1.6.3 (methodology) and Section  
 3 1.6.5 (results), this hazard is **Very Frequent/Very Probable** because significant occurrences of this hazard have happened recently  
 4 and will likely occur again in the future. The overall risk ranking for this hazard is **High**.

5 The City of Norton and Wise County are two jurisdictions considered to be at "higher" risk to winter weather events according to the  
 6 2018 Commonwealth of Virginia Hazard Mitigation Plan. The western and northern areas of the Commonwealth experience greater  
 7 risk in general, based on trends in lower temperatures, snowfall, and winter precipitation of all types.

**TABLE: Winter Weather Hazard Ranking Parameters**  
 Source: 2018 Commonwealth of Virginia Hazard Mitigation Plan

Jurisdiction	Population Vulnerability	Population Density	Injuries & Fatalities	Property Damage	Crop Damage	Events	Geographic Extent	Total Risk Ranking
City of Norton	Low	Medium-High	Low	Low	Low	High	High	Medium
Lee County	Medium	Low	Low	Low	Low	Medium-High	Medium-High	Medium-Low
Scott County	Medium	Low	Low	Low	Low	Medium-High	Medium-High	Medium-Low
Wise County	Medium	Medium	Low	Low	Low	High	High	Medium

8



## 1 Geographic Location

2 Although the Commonwealth of Virginia is not generally associated with severe winter storms,  
3 the mountainous area in the southwest region regularly experiences several snow storms each  
4 year. Winter weather events in Virginia typically include snowstorms, freezing temperatures, ice  
5 storms, and sleet or freezing rain. Most often, winter weather results from Nor'easter storm  
6 patterns which can produce significant snowstorms throughout the mid-Atlantic, typically  
7 between November and April. Nor'easters also bring strong winds, which when combined with  
8 frozen precipitation can significantly damage trees and utility lines.

9 One of the most significant seasonal snowfalls in the Commonwealth's history took place in  
10 Wise County during the winter of 1995-1996 when a recorded 124.2 inches of snow fell. On  
11 average, southwestern Virginia will experience one or two severe winter storms each year.  
12 Snowfalls amounts for these storms can vary from a few inches to a foot of snow in extreme  
13 cases. The higher elevations of the district (i.e. High Knob in the Jefferson National Forest) can  
14 experience as much as 48 inches of snow in a severe winter storm.

15 The winter storm hazard can impact all jurisdictions within the LENOWISCO Planning District,  
16 but the total average annual snowfall within the district varies by jurisdiction. Lee County has an  
17 average annual snowfall of 14 inches per year, Scott County 9 inches per year, Wise County 37  
18 inches per year, and the City of Norton 15 inches.

## 19 Loss Estimates

20 Economic impacts arise from numerous sources including hindered transportation of goods and  
21 services, flooding due to burst water pipes, forced closing of businesses, the inability of  
22 employees to reach the workplace, damage to homes and structures, automobiles, and other  
23 belongings by downed trees and branches, loss of livestock and vegetation and many others.  
24 There were no reported losses from winter weather events in the LENOWISCO Planning District  
25 from 2015-2020. The 2018 Virginia HMP estimates a statewide annualized loss of about \$5.4  
26 million based on the NOAA NCEI Storm Events Database. This is likely an underestimate, as it  
27 does not include many societal costs such as lost productivity and energy consumption.

## 28 Vulnerability and Community Development Analysis

29 Winter storms are a regular occurrence in the LENOWISCO Planning District. Storm impacts  
30 are distributed across the entire District. Impacts increase in communities with higher annual  
31 snowfall (Wise County) and those that are isolated by a few critical roadways that may be  
32 impacted by winter storm conditions and heavy snowfall. While the District is accustomed to  
33 winter storm events, communities can be crippled by road closures that can limit emergency  
34 response, utility repair, or supply delivery. Planning committee members noted that power  
35 outages can last up to a week after a major winter storm, and the overhead power lines across  
36 the region are vulnerable to outages and damage from heavy snow.

## 37 *Impact on LENOWISCO Residents*

38 The vulnerability to severe winter storms is like extreme temperatures. Severe winter weather  
39 poses a threat to the lives and safety of individuals exposed. Most deaths correlated to winter



1 storms are not directly related to the storm itself. The three causes of deaths commonly  
2 associated with "side-effects" of winter storms are:

- 3 • Traffic accidents on icy roads.
- 4 • Heart attacks while shoveling snow.
- 5 • Hypothermia from prolonged exposure to cold.

6 While everyone is at-risk during a winter storm, the actual threat varies by a person's specific  
7 situation. Of injuries related to ice and snow ([NSSL](#)):

- 8 • About 70% occur in automobiles.
- 9 • About 25% are people caught out in the storm.
- 10 • The majority are males over 40 years old.

11 Of injuries related to exposure to cold ([NSSL](#)):

- 12 • 50% are people over 60 years old.
- 13 • Over 75% are males.
- 14 • About 20% occur in the home.

15 Severe winter weather events are a threat to all residents, but certain groups are especially at  
16 risk and require special attention from jurisdictions. Those most at risk from severe winter  
17 weather include the elderly, people with disabilities or requiring medical support, and  
18 socioeconomically disadvantaged individuals.

19 People with disabilities, including those with mental health disorders, limited communication, or  
20 physical disabilities are very vulnerable to severe winter storms. Physically disabled individuals  
21 may rely on power for life-essential treatments such as oxygen, dialysis, or heart-monitoring  
22 devices. These critical devices may become dysfunctional during a power outage. Individuals  
23 with limited mobility or agility, including the elderly, are also at greater risk of injuries from falling  
24 on slippery surfaces. An average of 18.38% of the population is over 65 years old in the District.  
25 The LENOWISCO Planning District has a higher disabled population than most of the United  
26 States, with an average of 25.3% individuals having at least one disability in the District versus  
27 12.6% for the entire United States. Some jurisdictions noted specific concerns for dialysis  
28 patients who need access to services from the regional dialysis center in Norton. This service  
29 can be disrupted due to power outages, as well as impassable roads after a significant storm.

30 Socioeconomically disadvantaged individuals, especially those without access to adequate  
31 heating at home or without reliable vehicles, will experience disproportionate vulnerability to  
32 winter weather dangers. In LENOWISCO, a little less than a quarter of the population is living at  
33 or below the poverty line (23.5%). The average in LENOWISCO is considerably higher than the  
34 national average of 14.1%. Additionally, individuals experiencing homelessness are extremely  
35 at risk of exposure due to lack of adequate shelter, limited access to heat, or poor clothing  
36 options. Individuals without stable housing may also seek shelter in structures that are  
37 vulnerable to winter weather events.

38



1 The table below highlights the statistics of the population most vulnerable to winter weather  
 2 events. The [2014—2018 ACS 5-Year Data and Narrative Profiles](#) for the City of Norton, Lee  
 3 County, Scott County, and Wise County provides insights on the percentage and number of  
 4 population members that are more susceptible to tornado impact. The Annexes to the plan  
 5 further provide a breakdown of vulnerabilities within each community in LENOWISCO.

<b>TABLE: Data Profile</b>				
<b>Source: American Community Survey, 2014-2018</b>				
<b>Area</b>	<b>Total Population</b>	<b>Disabled</b>	<b>Individuals in Poverty</b>	<b>Individuals Over 65 years old</b>
City of Norton	3,990	23.6% (929)	29.4%	14.2% (689)
Lee County	24,134	25.9% (5,859)	24%	19.7 % (4,759)
Scott County	22,009	24.8% (5,286)	18.6%	22.7% (4,999)
Wise County	39,025	26.9% (9886)	22%	16.9% (6,583)

6 ***Impact on Essential Facilities and Other Property***

7 Essential facilities will experience similar impacts as other buildings in the district. Impacts to  
 8 facilities could include loss of gas or electricity from broken or damaged utility lines, damaged or  
 9 impassable roads and railways, broken water pipes, and roof collapse from heavy snow.

10 Critical infrastructure vulnerable to a winter storm includes roadways, utility lines/pipes, and  
 11 bridges. Potential impacts include broken gas and/or electricity lines or damaged utility lines,  
 12 damaged or impassable roads and railways, and broken water pipes. Excess ice accumulation  
 13 and high-speed winds can significantly damage infrastructure, including power lines and  
 14 communication towers, or causing fallen trees.

15 Any new development within the District will remain vulnerable to these events. However,  
 16 because structures that are older are more likely to be vulnerable to heavy snow or ice, newer  
 17 construction may be more resilient to this hazard.

18 ***Impact on the Environment***

19 Excess ice or significant snowfall can lead to significant tree damage and fallen branches.  
 20 Winter conditions can impact livestock and make it more difficult for animals to access food and  
 21 water. Additionally, wet or flooding conditions can impact local ecosystems, including  
 22 encouraging the spread of mold/fungi, disrupting the local food chain, or spreading pollution.

23 ***Impact on Operations***

24 Operations could be impacted by secondary hazards such as structural damage from snow,  
 25 wind damage, hazardous driving conditions, service or communication disruptions, or power  
 26 outages. These hazards may impact first responder capabilities and the prompt response to  
 27 emergencies. Power outages may also cause many critical facilities to rely on backup power  
 28 temporarily.



1 Hazard Evaluation and Impact/Consequence Assessment

Frequency & Probability <sup>1</sup>	Very Vulnerable		
Potential Magnitude and Scale <sup>1</sup>	Somewhat Vulnerable		
Physical Vulnerability Hazard Impact <sup>1</sup>	Vulnerable		
Social Vulnerability Hazard Impact <sup>1</sup>	Vulnerable		
Community Conditions Hazard Impact <sup>1</sup>	Vulnerable		
Overall Capability and Capacity <sup>2</sup>	Somewhat Capable		
Mitigation <sup>2</sup>	Somewhat Capable		
Hazard Consequence & Impact Score <sup>1</sup>	Vulnerable		
Overall Risk Rating <sup>3</sup>	High		
Legend			
Score	1: Vulnerability Rating	2: Capability and Capacity Rating	3: Overall Risk Rating
0 – 24	Minimally Vulnerable	Minimally Capable	Low
25 – 49	Somewhat Vulnerable	Somewhat Capable	Medium
50 – 74	Vulnerable	Capable	High
75 - 100	Very Vulnerable	Very Capable	Extreme
N/A	Not Applicable/Unknown	Not Applicable/Unknown	Not Applicable/Unknown

2  
3

DRAFT





## 1 1.6.12 Solar Storm

2 *The following profile was created for the Solar Storm hazard due to its inclusion in the 2018*  
3 *Commonwealth of Virginia Hazard Mitigation Plan. The planning team unanimously determined*  
4 *not to complete a full hazard profile or include Solar Storm in the risk assessment and mitigation*  
5 *strategy due to a lack of information on potential vulnerabilities and hazard impacts. This*  
6 *decision can be revisited in the next update of the plan if additional data is made available.*

7 Solar storms, and more broadly space weather, are caused by eruptions on the sun (solar flares  
8 and coronal mass ejections). These storms are the result of changes in the flow of solar  
9 particles and magnetic fields from the sun. Solar storms can occur in near-Earth space or in  
10 Earth's atmosphere. Technology is particularly vulnerable to space weather and solar storms.  
11 Solar storms include three categories:

- 12 • **Geomagnetic storms:** electrical currents that can have a significant impact on electrical  
13 transmission equipment, which can result in widespread electrical failures and  
14 interruptions to navigational and GPS systems. Additionally, geomagnetic storms can  
15 affect satellites, which we rely on for radio and television, credit card transmission, and  
16 cell phones.
- 17 • **Solar radiation storms:** these storms are of greatest concern for aircraft control.
- 18 • **Radio blackouts:** impact high-frequency communications and the sectors that rely on  
19 them, including emergency responders.

20 NOAA's Space Weather Prediction Center (SWPC) forecasts space weather to help avoid or  
21 mitigate the impacts of solar storms. This includes real-time monitoring and forecasting of solar  
22 events, and issues watches, warnings, and alerts.

### 23 Hazard Extent

24 According to the 2018 Commonwealth of Virginia Hazard Mitigation Plan (HMP), the solar storm  
25 hazard cannot be easily expressed in specific recurrence intervals as with other hazard events.

### 26 History/Previous Occurrences

27 There are no recorded occurrences of solar storm events or impacts in either the LENOWISCO  
28 Planning District or the Commonwealth of Virginia, according to the 2018 Virginia HMP. The last  
29 recorded solar storm event on Earth was more than 150 years ago.



- 1 Future Probability
- 2 The probability of a solar storm event cannot be predicted, but NASA can provide some warning of storms before we feel their
- 3 impacts. This hazard has a low probability for the entirety of the LENOWISCO Planning District as well as within the Commonwealth
- 4 of Virginia HMP.

**TABLE: Solar Storm Hazard Ranking Parameters**  
*Source: 2018 Commonwealth of Virginia Hazard Mitigation Plan*

Jurisdiction	Population Vulnerability	Population Density	Injuries & Fatalities	Property Damage	Crop Damage	Events	Geographic Extent	Total Risk
City of Norton	Low	Medium-High	Low	Low	Low	Low	Low	Low
Lee County	Medium	Low	Low	Low	Low	Low	Low	Low
Scott County	Medium	Low	Low	Low	Low	Low	Low	Low
Wise County	Medium	Medium	Low	Low	Low	Low	Low	Low

5  
 6 Geographic Location

- 7 If a solar storm were to occur, it would have wide-reaching impacts across the LENOWISCO district as well as the Commonwealth
- 8 and eastern seaboard.

9 Loss Estimates

- 10 Due to the lack of intensity-damage models for solar storm events, it is not currently possible to estimate losses.



1 Vulnerability and Community Development Analysis

2 The most significant impact of a solar storm event would be the disruption of electrical power  
3 transmission and high-frequency radio transmission. The LENOWISCO Planning District,  
4 Virginia, and the world are increasingly reliant on these systems for communication, emergency  
5 operations, essential services, and critical infrastructure. All of this technology is vulnerable to a  
6 solar storm event.

7 *Impact on LENOWISCO Residents*

8 Residents are likely to experience impacts due to the disruption of power systems,  
9 communication, or other technologies. These disruptions could affect the delivery of services or  
10 short-term economic impacts.

11 *Impact on Essential Facilities, Critical Infrastructure, and Other Property*

12 Essential facilities are likely to be impacted by electrical outages and communications issues  
13 because of a solar storm event.

14 The greatest impact of a solar storm is the disruption of electrical power transmission and high-  
15 frequency radio communications. The power grid and power distribution could also be disrupted.  
16 There is also the possibility of partial or system-wide blackouts due to voltage instability and  
17 high-power demand from tripped transformers.

18 *Impact on the Environment*

19 Electrical issues stemming from a solar storm event could lead to an increased risk of fires.

20 *Impact on Operations*

21 High-frequency radio communication is commonly used across government agencies and  
22 private industries. Many essential operations depend on reliable access to communications,  
23 posing significant vulnerability to solar storms or other space weather.

24



## 1 **1.6.13 Risk Assessment Methodology**

2 The LENOWISCO Planning District recognizes that the Hazard Risk Assessment is the  
3 fundamental building block of the four core functions of emergency management: mitigate,  
4 prepare, respond, and recover. In today's hazard environment, emergency management is the  
5 crux of solving the complex challenges that face communities during an emergency or following  
6 a disaster.

7 The Federal Emergency Management Agency (FEMA) defines mitigation as “the effort to  
8 reduce the loss of life and property by lessening the impact of disasters” ([FEMA, 2018](#)). FEMA  
9 furthers this definition by providing three key areas that need to happen before a disaster.  
10 These areas are analyzing risk, reducing risk, and insuring against risk. FEMA also asserts that  
11 disasters can happen at any time and in any place, which is an important reason why all  
12 communities need to be empowered to assess short and long-term risks. While assessing  
13 involves financial backing, the actual implementation of mitigation tactics involves the most  
14 significant financial barriers. Mitigation financial barriers must be reframed as investments and  
15 preventative measures to a much higher economic and human loss that could result from an  
16 unmitigated disaster ([FEMA, 2018](#)).

17 Mitigation should be viewed as a proactive solution to protect a community ahead of any threat  
18 of an emergency or disaster impact. Mitigation can provide whole communities with the tools to  
19 be resilient before and after a disaster. While mitigation tactics do require financial investment,  
20 both short-term for implementation and long-term for maintenance, investing in mitigation should  
21 ultimately lessen the financial burden on society. The Multi-Hazard Mitigation Council initially  
22 estimated that each dollar spent on mitigation saves society an average of four dollars, which  
23 equates to a 400% savings on disaster spending, which is a growing domestic fiscal burden.  
24 More recently, the Multi-Hazard Mitigation Council reported that every \$1 invested in mitigation  
25 building equates to \$11, thus an 1100% savings. Another study found that \$1 spent on hazard  
26 mitigation can save the nation \$6 in future disaster costs ([NIBS, 2019](#)).

### 27 Hazard Assessment Methodology

28 The objective of the risk methodology is to devise a process to compare and evaluate which  
29 hazards are the greatest threats to the District and where mitigation actions should be focused  
30 to provide the best value. The Risk Assessment describes, analyzes, and assesses the risks  
31 facing the District from natural hazards. Natural hazards are those events that are a result of our  
32 surrounding environment, such as tornadoes and flooding.

33 Past disaster events, both natural and human-caused, indicate that disasters cannot be viewed  
34 or solved as isolated instances. In other words, the rising number of disasters and ensuing  
35 damages, including human losses, can be “symptoms of broader and more basic  
36 problems.” These problems stem from the intricate relationships society shares with both the  
37 natural and constructed environments.

38 According to Dr. Denis Mileti:

39 *“Many disaster losses – rather than stemming from unexpected events – are the*  
40 *predictable result of interactions among three major systems: the physical environment,*  
41 *which includes hazardous events; the social and demographic characteristics of the*



1 *communities that experience them; and the buildings, roads, bridges, and other*  
2 *components of the constructed environment”.*

3 Source: Mileti, Denis (1999). *Disasters by Design*. Joseph Henry Press: Washington, DC.

4 Dr. Mileti’s findings demonstrate that these destructive events must be understood and  
5 assessed from a holistic point of view and that current and future solutions for reducing  
6 damages and human losses must acknowledge that disasters occur at the intersection of the  
7 physical environment, social community characteristics, and the constructed environment. While  
8 the escalating losses from disasters will continue to result, in part, from the continuing  
9 expansion of the built environment, it can also be attributed to the fact that “all these systems –  
10 and their interactions – are becoming more complex with each passing year.”

11 Therefore, the Risk Assessment assumed that hazard events exacerbate pre-existing conditions  
12 of a community and that a community’s hazard risk is a function of its vulnerability and potential  
13 hazard impact. To mitigate these risks and hazards, capacities, and capabilities of managing  
14 potential impacts are evaluated as well as a disaster’s cascading effects on communities,  
15 residents, essential services, and critical assets. The figure below provides a general illustration  
16 of this relationship between the pre-existing conditions in a city (i.e., pre-disaster vulnerability  
17 and efforts to mitigate and build capabilities) and the potential impact from various hazards.

18 Although incorporating vulnerability, capability, and cascading impacts in a risk assessment are  
19 complex, it is imperative to include these relationships in the methodology to the best ability  
20 possible to ensure the usefulness of the outputs. Understanding these interdependent  
21 relationships can assist in operational, hazard, agency, and community planning.

22 Many of the hazards in the Risk Assessment do not pose a significant risk because of their low  
23 probability of occurring or minimal impact; however, these hazards are still addressed in this  
24 Plan. Hazards that were determined to not occur in the District were removed from the Risk  
25 Assessment.

## 26 Community Vulnerability Risk and Resiliency (CVR2)

27 Each hazard is evaluated using the CVR2 process, which is based on the probability of a  
28 hazard occurring, the potential magnitude of the hazard, and potential impacts. The CVR2  
29 hazard assessment also provides consideration to the community’s efforts to mitigate and build  
30 capacity to manage each hazard threat. The CVR2 hazard risk analysis incorporates the  
31 outputs provided by the vulnerability and capability/capacity indices to provide an overall hazard  
32 risk score that can be prioritized. The following table identifies the indicators and  
33 measurements, describes why these are important, and presents the key used to evaluate each  
34 indicator.

35 Building off the theoretical finding that disasters are not isolated events, the CVR2 process  
36 analyzes a series of vulnerability indices to evaluate the different types of impacts that may be  
37 possible by the hazard. Categories are areas of potential vulnerability (for example, social  
38 vulnerability) and further evaluated based on a series of scientific indicators like special  
39 population types such as the elderly. Each indicator is assessed to provide a complete picture of  
40 the potential impact that each hazard poses on the community. The following table identifies the  
41 indicators and measurements, describes why these are important, and presents the key used to  
42 evaluate each indicator.





TABLE: Hazard Assessment		
Indicators & Measurements	Description	Rating Key
Hazard-Specific Frequency & Probability	Frequency of past occurrences and the probability of future incidents based on predictive modeling or scientific research.	Extreme
		High
		Medium
		Low
Hazard-Specific Magnitude & Scale	The potential magnitude of the hazard and scale or size of the hazard.	Extreme
		High
		Medium
		Low
Capability & Capacity	The community's ability and capacity to manage the hazard, such as floodplain management programs or anti-terrorism surveillance.	Very Capable
		Capable
		Somewhat Capable
		Minimally Capable
Mitigation Assessment	The community's efforts to mitigate the hazard, such as buying out flood-prone properties, building codes, etc.	Very Capable
		Capable
		Somewhat Capable
		Minimally Capable
Consequence & Impact Assessment	The potential severity of the impacts and consequences of the event. This assessment provides consideration to the Hazard Impact Analysis.	Extreme
		High
		Medium
		Low

1

2



**TABLE: Hazard Impact Analysis**

Categories and Indicators	Rating Key	Physical Vulnerabilities Hazard Impact Analysis
<p>Physical Vulnerabilities Hazard Impact Analysis</p> <ul style="list-style-type: none"> <li>• Critical Infrastructure</li> <li>• Key Resources</li> <li>• Building Stock</li> </ul>	<p>The built environment provides the setting for human activity, ranging in scale from personal residential structures and buildings to neighborhoods and cities that often include supporting infrastructures, such as transportation networks, energy, and water systems. The CVR2's Physical Vulnerability Index (PVI) evaluates critical infrastructure, key resource assets, and building stock risk exposure to hazards using a series of indicators and measurements.</p>	
<p>Social Vulnerabilities Index (SVI)                      Hazard Impact Analysis</p> <ul style="list-style-type: none"> <li>• Special Populations</li> <li>• Cultural Conditions</li> <li>• Socio-Economic Conditions</li> </ul>	<p>Social vulnerability can be broadly viewed as the characteristics of a person or group and their situation that influence their capacity to anticipate, cope with, resist and recover from the impact of a hazard or threat. Social vulnerability can also be looked at as the susceptibility of community groups (elderly, children, etc.) to the impacts of hazards, as well as their resiliency or ability to adequately recover from them. It should be noted that susceptibility is not only a function of demographic characteristics, but also more complex factors such as health care provision, social capital, and access to lifelines. The CVR2's Social Vulnerability Index (SVI) evaluates the hazard risk exposure of special population types, socio-economic conditions, and cultural conditions using a series of open-source data measurements. There are a number of potential special populations that may be used in the descriptions below including:</p> <ul style="list-style-type: none"> <li>• Children: Those under 18 years old</li> <li>• Dialysis Patients: Patients who are reliant on dialysis to survive</li> <li>• Disabled: Those who have a mental or cognitive disability</li> <li>• Elderly: Those over 65</li> <li>• Low-Income/Poor: Those who do not make a living wage or are below the poverty line</li> <li>• Non-English speakers</li> <li>• Pet Owners: Those who live with and/or take care of animals</li> <li>• Transient: Tourists, commuters, and homeless</li> <li>• University Students: Those who attend a college or university</li> <li>• Vehicle Ownership: Those who do not have access to a vehicle</li> </ul>	
<p>Community Conditions Vulnerability Index (CVI) Hazard Impact Analysis</p> <ul style="list-style-type: none"> <li>• Community Organizations</li> <li>• Economic Conditions</li> <li>• Environmental Conditions</li> <li>• Government Conditions</li> <li>• Special Properties</li> </ul>	<p>Community-level indicators are measures of conditions that consider how the area may be impacted during a hazard event. A community is a complex system of many interconnected components. This assessment is not meant to capture this system in its entirety, but rather, to focus on specific categories of indicators. The CVR2's Community Conditions Vulnerability Index (CVI) focuses specifically on four broad categories (economic, environmental, community organizations, and governmental conditions), comprised of a series of evidence-based indicators and measurements of community vulnerability.</p>	



1 The value of the CVR2 assessment is the ability to compare a wide variety of hazards and  
2 threats, from floods to acts of terrorism, using the same format for each hazard type. The  
3 scoring mechanism enables the community to identify areas of strength and weakness, as well  
4 as support the case for further mitigation and planning projects to build up the area's resilience.

#### 5 Limitations

6 The analysis of hazards is complicated by several factors including laws, customs, ethics,  
7 values, attitudes, political preferences, complex infrastructures, and the built environment. The  
8 hazard analysis developed for the Plan should be considered an initial step to evaluate the  
9 community's hazards. A hazard analysis, however, does provide a wealth of valuable  
10 information that is essential for identifying goals, prioritizing actions, planning, and  
11 preparedness, and recovering and mitigating future hazards.

12 The assessment of data and identifying the risk to a community is not hard science. It is not  
13 possible to predict hazards or their impacts. Hazard analysis data and conclusions are not  
14 absolute. The perception of what constitutes a risk and a judgment of its impact can differ from  
15 individual to individual. The changing natural, built, or societal environments can have a  
16 significant effect on each hazard assessment. For this reason, it is essential to update this  
17 document periodically. A hazard risk assessment does provide a guide to evaluate the District's  
18 risks and guide the mission of protecting its residents and interests.

#### 19 Hazard Risk Determination

20 The determination of the risks associated with each hazard was not based on empirical values.  
21 Instead, it is based on a function of the probability of the event occurring and its potential  
22 impact. This approach was necessary due to the complexities of a uniformed all-hazard  
23 approach and the numerous direct and indirect factors for District.

24 At the most fundamental level, both DHS and FEMA recognize that risk is equal to the  
25 frequency (and/or probability) multiplied by consequence ( $R = F \times C$ ). More specifically, in order  
26 to have a certain level of risk, there must be a probability or likelihood for that event to occur.  
27 Likewise, if the event does happen, but there is no impact or consequence, the level of risk is  
28 negated or substantially reduced.

#### 29 Determining the Probability

30 The likelihood, frequency, and/or probability of a hazard occurring in the District was established  
31 by assessing each hazard with the following factors, as described below. Actual data and/or  
32 predictive models and/or analyses were used in determining the likelihood/frequency/probability  
33 of the hazards. Local subject matter expertise was leveraged when data/analyses were  
34 insufficient and/or incomplete in describing the actual likelihood of a hazard. The  
35 frequency/probability score is meant to represent the probability or likelihood of a "significant or  
36 unusual" incident, but not necessarily the worst-case scenario. The decision to use "significant  
37 or unusual" incidents in determining probability was made to eliminate factoring recurrent and/or  
38 common hazard incidents that would bias the probability score for specific hazards, such as, but  
39 not limited to severe thunderstorms, transportation incidents, etc. Furthermore, these recurrent  
40 and/or common hazard incidents would not necessarily pose a significant threat to the District,



1 nor would they require additional capabilities beyond what is normal. This approach is  
 2 consistent with the THIRA guidelines.

3 **Frequency/Probability Factors:** In determining frequency/probability, the tool assessed the  
 4 following factors for each hazard.

- 5 • In general, how would you rate the probability of this hazard occurring in your  
 6 jurisdiction?
- 7 • Since 1952 (past 60 years), how would you rate the frequency of this hazard occurring in  
 8 your jurisdiction?
- 9 • On average, what do most predictive models indicate is the probability of this hazard  
 10 occurring in your jurisdiction?
- 11 • How would you rate the frequency of events that have occurred within the jurisdictional  
 12 boundaries of your jurisdiction in the last five years?

13 Scores were assigned based on the following measurements below. As described previously,  
 14 actual data and/or predictive models and/or analyses, when available, were used in determining  
 15 the best option. Local subject matter expertise was leveraged when data/analyses were  
 16 insufficient and/or incomplete in describing the actual probability of a hazard:

- 17 • Unlikely/Not Probable at All/Not Frequent At All
  - 18 ○ Extremely rare and/or no documented history of significant occurrences or
  - 19 ○ events; or
  - 20 ○ Significant events may occur every 100 or more years
- 21 • Possibly/Somewhat Probable/Somewhat Frequent
  - 22 ○ Rare significant occurrences with at least one to two documented or anecdotal
  - 23 ○ historical events; or
  - 24 ○ Significant events may occur every 25-100 years
- 25 • Likely/Probable/Frequent
  - 26 ○ Occasional significant occurrences with at least three or more documented
  - 27 ○ historic events; or
  - 28 ○ Significant events may occur every 5 to 25 years.
- 29 • Highly Likely/Very Probable/Very Frequent
  - 30 ○ Frequent events with a well-documented history of significant occurrences; or
  - 31 ○ Significant events may occur every 1 to 5 years.

32 **Overall Frequency/Probability Scores:** Once frequency/probability was determined for each  
 33 hazard, one of four categories was assigned based on the corresponding score. The higher the  
 34 number, the more probable the hazard is likely to occur in the District.

TABLE: Frequency/Probability Ranges		
Very Probable/Very Frequent	Score: 75-100	
Probable/Frequent	Score: 50-74	
Somewhat Probable/Somewhat Frequent	Score: 25-49	
Not Probable at All/Not Frequent At All	Score: 0-24	

35  
 36



1 Determining the Consequence

2 Whereas measuring the frequency/probability of a hazard is often straightforward, defining, and  
 3 measuring the consequence is more complicated. At the most basic level, the consequence is  
 4 an assessment of the potential impact(s) if the attack or hazard incident occurs. In this  
 5 assessment, the result of an event (or the impact) will be interdependent on the following  
 6 factors: vulnerabilities (i.e., social, physical, and community conditions), capabilities and  
 7 capacities, mitigation, and the characteristics (i.e., magnitude, scale, etc.) of the hazard event or  
 8 attack itself. Again, the frequency/probability of the hazard is not included in assessing the  
 9 consequence because, without the event, there is no consequence or impact.

10 As stated previously, the process assumes that hazard events exacerbate pre-existing  
 11 conditions of a community. To understand and capture the likely consequence of an event, one  
 12 must not only understand the characteristics of the hazard (magnitude, scale, extent, etc.) but  
 13 must also understand the features of the impacted community and its associated vulnerabilities  
 14 and capabilities. The figure below provides a visual sample of how pre-existing community  
 15 conditions were determined.

16 *Sample of the Vulnerability Index Methodology and Process*

17 The algebraic conceptual framework that drives the CVR2 tool is based on the overarching  
 18 premise that the impacts of a disaster are a direct correlation to the pre-existing conditions and  
 19 vulnerabilities of the community; and secondly, although risk exposure can be reduced, a  
 20 community can never wholly eliminate disaster impacts by implementing mitigation projects or  
 21 by building capabilities and capacities.

22 *Risk Assessment Methodology and Formula*

$$\left[ \begin{array}{c} \text{Probability} \\ \text{and} \\ \text{Frequency} \end{array} \right] \times \left[ \begin{array}{c} \text{Potential} \\ \text{Magnitude \&} \\ \text{Scale} \end{array} \right] \left[ \begin{array}{c} fV_1 \left[ \begin{array}{c} \text{Average Social} \\ \text{Vulnerability-} \\ \text{Impact Score} \end{array} \right] + \left[ \begin{array}{c} \text{Average Physical} \\ \text{Vulnerability-} \\ \text{Impact Score} \end{array} \right] + \left[ \begin{array}{c} \text{Average Community} \\ \text{Conditions Vulnerability-} \\ \text{Impact Score} \end{array} \right] \\ fX_1 \left[ \begin{array}{c} \text{Average Capabilities \&} \\ \text{Capacities Score} \end{array} \right] + \left[ \begin{array}{c} \text{Average Mitigation} \\ \text{Score} \end{array} \right] \end{array} \right] \left. \right] \wedge \left( \frac{fV_2}{fX_2} \right)$$

23  
 24 The algorithm above recognizes that the potential impact from a hazard is a function of the pre-  
 25 existing vulnerabilities in a community. Additionally, the algorithm recognizes that although you  
 26 can reduce your potential impact and vulnerability to hazards by increasing your capability and  
 27 implementing mitigation, the vulnerability cannot be eliminated. Communities cannot achieve  
 28 absolute resiliency to any hazard.

29 More specifically, the variable **fV** represents the numeric relationship that although there is a  
 30 direct correlation between a community’s vulnerability and potential impacts; the extent of the  
 31 vulnerability exposure varies from hazard to hazard. Similarly, **fX** represents the numeric  
 32 relationship that recognizes that capabilities, capacities, and ability to mitigate cannot eliminate  
 33 a threat and, therefore, cannot be absolute. In simple terms, vulnerability, capability, and  
 34 mitigation will never be more than 100% or less than 0% (both of which would be practically and  
 35 theoretically impossible).





1 Finally, the algorithm recognizes that communities can have vulnerabilities, capabilities,  
2 capacities, and the ability to mitigate that are specific to the community and therefore, should be  
3 considered all hazards. This is represented in the ***fv1*** and ***fx1*** variables. An example of this  
4 would be a community's overall level of preparedness or trust in government. Additionally,  
5 communities may also have hazard-specific vulnerabilities or taken hazard-specific measures to  
6 mitigate or build capabilities to manage a specific hazard. This is represented by  
7 the ***fv2*** and ***fx2*** variables. An example of this would be a community participating in FEMA's  
8 National Flood Insurance Program.

9

DRAFT



1 **1.6.14 Hazard Rankings**

2 Each hazard was scored as to magnitude and frequency of occurrence, as well as assigned an  
 3 overall risk ranking through the CVR2 Community Hazard Risk Assessment  
 4 Methodology outlined in the previous section. The legend below outlines the scoring categories  
 5 and assigned ratings.

Legend				
Score	Frequency & Probability Rating	Vulnerability Rating	Capability and Capacity Rating	Overall Risk Rating
0 – 24	Not Probable at All/ Not Frequent At All	Minimally Vulnerable	Minimally Capable	Low
25 – 49	Somewhat Probable/ Somewhat Frequent	Somewhat Vulnerable	Somewhat Capable	Medium
50 – 74	Probable/Frequent	Vulnerable	Capable	High
75 - 100	Very Probable/ Very Frequent	Very Vulnerable	Very Capable	Extreme
N/A		Not Applicable	Not Applicable	Not Applicable

6

DRAFT



- 1 The table below provides a summary of frequency and probability, as well as overall risk ranking by hazard. The table includes a
- 2 comparison to the hazard rankings included in the 2013 Hazard Mitigation Plan. Hazards that were not included in the 2013 Risk
- 3 Assessment are noted as not applicable. The 2013 plan included the additional hazards of Severe Thunderstorm/Hail and Extreme
- 4 Heat, which were not included in the 2021 plan. A comparison of this hazard ranking with public survey results is included later in this
- 5 section.

**TABLE: Hazard Risk Ranking for LENOWISCO Planning District**  
*Complete Hazard Ranking Table is included here*

Hazard	2021 Hazard Rankings				2013 Risk Ranking
	Frequency & Probability	Frequency & Probability	Risk Ranking	Risk Ranking	
Flooding	75	Very Probable/Very Frequent	69	High	High
Non-Rotational Wind	75	Very Probable/Very Frequent	68	High	Medium-High (combined with Tornado)
Winter Storm	75	Very Probable/Very Frequent	67	High	Medium-High
Wildfire	50	Probable/Frequent	53	High	Medium
Communicable Disease	38	Somewhat Probable/Somewhat Frequent	47	Medium	N/A
Landslide	44	Somewhat Probable/Somewhat Frequent	47	Medium	Medium (combined with Land Subsidence, Soil Erosion)
Karst/Subsidence	31	Somewhat Probable/Somewhat Frequent	41	Medium	Low (Karst topography only)
Tornado	25	Somewhat Probable/Somewhat Frequent	39	Medium	Medium-High (combined with Non-Rotational Wind)
Drought	19	Not Probable at All/Not Frequent at All	28	Medium	Medium-High
Earthquake	13	Not Probable at All/Not Frequent at All	25	Medium	Medium
Dam Failure	6	Not Probably at All/Not Frequent at All	19	Low	Low

6  
 7



- 1 Finally, the table below provides the complete results of the CVR2 Community Hazard Risk Assessment. Further details on the
- 2 CVR2 assessment are in the Risk Assessment Methodology section.

**TABLE: Hazard Risk Assessment Results, Part One**

Hazard	Frequency & Probability	Potential Magnitude & Scale	Physical Vulnerability Hazard Impact Rating	Social Vulnerability Hazard Impact Rating	Community Conditions Hazard Impact Rating
Communicable Disease	38 Somewhat Vulnerable	45 Somewhat Vulnerable	41 Somewhat Vulnerable	74 Vulnerable	66 Vulnerable
Dam Failure	6 Minimally Vulnerable	31 Somewhat Vulnerable	60 Vulnerable	61 Vulnerable	63 Vulnerable
Drought	19 Minimally Vulnerable	2 Minimally Vulnerable	49 Somewhat Vulnerable	55 Vulnerable	50 Vulnerable
Earthquake	13 Minimally Vulnerable	17 Minimally Vulnerable	64 Vulnerable	55 Vulnerable	53 Vulnerable
Flooding	75 Very Vulnerable	30 Somewhat Vulnerable	67 Vulnerable	76 Very Vulnerable	67 Vulnerable
Karst/Subsidence	31 Somewhat Vulnerable	16 Minimally Vulnerable	55 Vulnerable	65 Vulnerable	60 Vulnerable
Landslide	44 Somewhat Vulnerable	8 Minimally Vulnerable	60 Vulnerable	69 Vulnerable	58 Vulnerable
Non-Rotational Wind	75 Very Vulnerable	35 Somewhat Vulnerable	64 Vulnerable	74 Vulnerable	66 Vulnerable
Tornado	25 Somewhat Vulnerable	25 Somewhat Vulnerable	67 Vulnerable	74 Vulnerable	63 Vulnerable
Wildfire	50 Vulnerable	16 Minimally Vulnerable	64 Vulnerable	74 Vulnerable	65 Vulnerable
Winter Storm	75 Very Vulnerable	32 Somewhat Vulnerable	67 Vulnerable	74 Vulnerable	66 Vulnerable

- 3
- 4



**TABLE: Hazard Risk Assessment Results, Part Two**

Hazard	Overall Capability & Capacity	Mitigation	Hazard Consequence & Impact Score	Risk Ranking
Communicable Disease	27 Somewhat Capable	27 Somewhat Capable	58 Vulnerable	47 Medium
Dam Failure	31 Somewhat Capable	39 Somewhat Capable	55 Vulnerable	19 Low
Drought	35 Somewhat Capable	17 Minimally Capable	43 Somewhat Vulnerable	28 Medium
Earthquake	25 Somewhat Capable	22 Minimally Capable	50 Vulnerable	25 Medium
Flooding	25 Somewhat Capable	11 Minimally Capable	63 Vulnerable	69 High
Karst/Subsidence	19 Minimally Capable	6 Minimally Capable	53 Vulnerable	41 Medium
Landslide	27 Somewhat Capable	28 Somewhat Capable	51 Vulnerable	47 Medium
Non-Rotational Wind	25 Somewhat Capable	22 Minimally Capable	62 Vulnerable	68 High
Tornado	25 Somewhat Capable	17 Minimally Capable	60 Vulnerable	39 Medium
Wildfire	32 Somewhat Capable	22 Minimally Capable	57 Vulnerable	53 High
Winter Storm	34 Somewhat Capable	33 Somewhat Capable	61 Vulnerable	67 High

1

2





## 1 Repetitive Loss Summary

2 [This section will be updated when repetitive loss data is made available by FEMA.]

3 According to the 2018 Commonwealth of Virginia Hazard Mitigation Plan, Virginia has  
4 6,564 know repetitive loss properties, according to the National Flood Insurance Program  
5 (NFIP) Policies, Claims, and Repetitive Loss Statistics. Based on the FEMA list which is based  
6 on the Biggert-Waters Flood Insurance Reform Act of 2012, [# of these properties are in the  
7 LENOWISCO Planning District.]

8 During the planning process, LENOWISCO Planning District requested the Repetitive Loss data  
9 from VDEM. VDEM requested the data from FEMA. Given the current pandemic, FEMA alerted  
10 VDEM of the delay in supplying Repetitive Loss data. Several jurisdictions in the District are  
11 aware of repetitive loss properties within their area and since the 2013 HMP, some acquisition  
12 projects have occurred. Given the history of repetitive loss, the jurisdictions that experience  
13 continued impacts from flooding developed mitigation actions to support flood reduction. Once  
14 the Repetitive Loss data is provided, it will be added to the plan to support the need for flood  
15 reduction mitigation projects and ensure the plan complies with 44CFR§201.4.

16 A repetitive loss property is a structure that:

- 17 • Has incurred flood-related damage on two occasions, in which the cost of the repair, on  
18 average, equaled or exceeded 25% of the market value of the structure at the time of  
19 each flood event; and
- 20 • At the time of the 2nd incidence of flood-related damage, the contract for flood insurance  
21 contains the increased cost of compliance coverage

22 A severe repetitive loss property is a structure that:

- 23 • Is covered under a contract for flood insurance made available under the NFIP; and
- 24 • Has incurred flood-related damage
  - 25 ○ For which four or more separate claims payments have been made under flood  
26 insurance coverage with the amount of each such claim exceeding \$5,000, and  
27 with the cumulative amount of such claims payments exceeding \$20,000; or
  - 28 ○ For which at least two separate claims payments have been made under such  
29 coverage, with the cumulative amount of such claims exceeding the market value  
30 of the insured structure.

31 [Given the number of RL or SRL structures are located in the LENOWISCO Planning District],  
32 many of the identified Mitigation Strategies (Section 1.7) highlight actions to reduce flooding to  
33 properties and structures.

34



1 Public Survey Comparison

2 Public involvement was an essential component to developing the plan and ensuring mitigation  
 3 actions were informed not only by the Hazard Risk Ranking but considered the public's  
 4 opinion.

5 One of the survey questions asked, "Do you believe that your household and/or place of  
 6 business might ever be threatened by the following hazards? Please rate what hazards present  
 7 the greatest risk." The public response indicated that Winter Storm was the highest risk hazard,  
 8 followed by Communicable Disease, as illustrated in the figure below. The Hazard  
 9 Rankings (Section 1.6.14) similarly identify Winter Storm as a high-risk hazard, while  
 10 Communicable Disease received a medium risk ranking. It is likely that perceived risk to a  
 11 Communicable Disease was elevated during the development of this plan due to the ongoing  
 12 COVID-19 pandemic.

13 This question also demonstrated that the public did not fully recognize the potentially damaging  
 14 impact of Flooding events could have across the District. The core planning team discussed  
 15 the ongoing impact of flooding on downtown areas, critical facilities, public buildings, roads, and  
 16 bridges. During the first planning team meeting (detailed in Section 1.4), the planning team  
 17 indicated that Flooding was one of the top hazards facing the District. The planning team  
 18 recognized that Flooding will continue to be both a high frequency and high impact hazard if left  
 19 unmitigated. While flooding is not a new hazard in the District, in 2013 it was rated as  
 20 the highest hazard, the survey demonstrated that the public may not fully understand the  
 21 potential impact and frequency of flooding events.

22 **FIGURE: Public Survey Responses, Question 15**

15. Do you believe that your household and/or place of business might ever be threatened by the following hazards? Please rate what hazards present the greatest risk. Low Risk = Low impact on threat to life and property damage Medium Risk = Medium impact on threat to life and property damage High Risk = High impact on threat to life and property damage

	Low Risk		Medium Risk		High Risk		Not Applicable		Responses Count
	Count	Row %	Count	Row %	Count	Row %	Count	Row %	
Communicable Disease	35	20.5%	63	36.8%	71	41.5%	2	1.2%	171
Drought	91	53.5%	65	38.2%	9	5.3%	5	2.9%	170
Earthquake	128	74.9%	32	18.7%	8	4.7%	3	1.8%	171
Flooding	74	43.3%	63	36.8%	31	18.1%	3	1.8%	171
Dam Failure	127	74.3%	21	12.3%	4	2.3%	19	11.1%	171
Karst	97	58.4%	22	13.3%	5	3.0%	42	25.3%	166
Subsidence	101	60.8%	35	21.1%	8	4.8%	22	13.3%	166
Landslide	103	60.2%	48	28.1%	11	6.4%	9	5.3%	171
Non-Rotational Winds	66	38.8%	79	46.5%	22	12.9%	3	1.8%	170
Solar Storm	114	68.3%	36	21.6%	3	1.8%	14	8.4%	167
Tornado	74	43.3%	86	50.3%	9	5.3%	2	1.2%	171
Wildfire	76	44.2%	67	39.0%	26	15.1%	3	1.7%	172
Winter Storm	5	2.9%	75	43.9%	89	52.0%	2	1.2%	171

23

24



1 Another question asked, "Based on YOUR PERCEPTION of your jurisdiction's hazards, to what  
 2 degree of emphasis would you expect your jurisdiction to mitigate the following hazards?  
 3 Mitigation definition: The purpose of mitigation planning is to identify policies and actions that  
 4 can be implemented over the long term to reduce risk and future losses. Mitigation forms the  
 5 foundation for a community's long-term strategy to reduce disaster losses and break the cycle of  
 6 disaster damage, reconstruction, and repeated damage."

7 The public survey responses to this question are illustrated in the figure below. Similarly to the  
 8 overall hazard risk ranking question, the public survey indicated an elevated concern for  
 9 mitigating the potential risk from Communicable Disease. The ongoing COVID-19 pandemic  
 10 likely influenced this response. While Communicable Disease is considered an important  
 11 hazard, with a Medium overall risk ranking, it is generally a less frequent/less probable event  
 12 then the top hazards of flooding, non-rotational wind, and winter storm events for the District.

13 Survey respondents noted other high priority hazards as winter storm and flooding, followed by  
 14 wildfire and tornado. When combined with the previous question, community members see the  
 15 importance of mitigating flooding issues, but do not see it as high risk. The other hazards are in  
 16 alignment with the hazard assessment results.

17 **FIGURE: Public Survey Responses, Question 21**

21. Based on YOUR PERCEPTION of your jurisdiction's hazards, to what degree of emphasis would you expect your jurisdiction to mitigate the following hazards?  
 Mitigation: The purpose of mitigation planning is to identify policies and actions that can be implemented over the long term to reduce risk and future losses. Mitigation forms the foundation for a community's long-term strategy to reduce disaster losses and break the cycle of disaster damage, reconstruction, and repeated damage. No Mitigation Needed = No mitigation on this hazard is expected or needed  
 Low Priority = This hazard should be mitigated, but is not a high priority compared to other hazards  
 Medium Priority = It is important to mitigate this hazard  
 High Priority = It is a high priority to emphasize mitigation for this hazard

	No Mitigation Needed		Low Priority		Medium Priority		High Priority		Do not know		Responses
	Count	Row %	Count	Row %	Count	Row %	Count	Row %	Count	Row %	
Communicable Disease	8	4.8%	16	9.6%	46	27.5%	91	54.5%	6	3.6%	167
Drought	24	14.5%	79	47.6%	46	27.7%	9	5.4%	8	4.8%	166
Earthquake	47	28.3%	78	47.0%	25	15.1%	9	5.4%	7	4.2%	166
Flooding	6	3.6%	22	13.3%	74	44.6%	59	35.5%	5	3.0%	166
Dam Failure	42	25.3%	61	36.7%	37	22.3%	13	7.8%	13	7.8%	166
Karst	42	25.6%	48	29.3%	25	15.2%	4	2.4%	45	27.4%	164
Subsidence	35	21.6%	56	34.6%	27	16.7%	12	7.4%	32	19.8%	162
Landslide	21	12.7%	64	38.8%	52	31.5%	22	13.3%	6	3.6%	165
Non-Rotational Winds	11	6.6%	63	38.0%	68	41.0%	12	7.2%	12	7.2%	166
Solar Storm	49	29.7%	72	43.6%	16	9.7%	5	3.0%	23	13.9%	165
Tornado	10	6.0%	74	44.6%	53	31.9%	24	14.5%	5	3.0%	166
Wildfire	9	5.4%	44	26.3%	73	43.7%	36	21.6%	5	3.0%	167
Winter Storm	1	0.6%	12	7.2%	62	37.1%	86	51.5%	6	3.6%	167

18

19



1 Interestingly, the most significant outlier across both questions is Non-Rotational Winds. Survey  
2 respondents generally ranked this as a medium risk hazard (46.5%) and a medium priority  
3 (41%) or low priority (38%) for mitigation actions. When asked what hazard events have caused  
4 damages in the past, wind events (including tornados and hurricanes) were frequently  
5 mentioned, as illustrated in the word cloud below. Non-Rotational Wind events tend to be  
6 frequent but lower impact hazards, likely contributing to this misalignment. People living in  
7 vulnerable housing, including mobile homes, may see this as a more significant hazard.

8 **FIGURE: Public Survey Responses, Question 17**



9  
10





## 1 1.7 Mitigation Strategies

### 2 1.7.1 Mitigation Goals and Objectives

3 The Mitigation Planning Team organized resources, assessed hazards and risks, and  
4 documented mitigation capabilities. The resulting goals, objectives, and mitigation actions were  
5 developed based on these tasks. The team held a series of meetings designed to develop  
6 mitigation strategies as described further throughout this section. Goals for this mitigation plan  
7 are statements that:

- 8 1. Represent the desires of the entire community
- 9 2. Include all members of the community both public and private
- 10 3. Can be accomplished in the future whether near-term or long-term

11 The Goals from the previous plan were:

- 12 1. Ensure public health and safety within the LENOWISCO planning region before, during,  
13 and following hazardous events.
- 14 2. Implement effective hazard mitigation measures that would minimize the impact of  
15 natural hazards on life and property for both existing and future development.
- 16 3. Increase the area's floodplain management activities and participation in the National  
17 Flood Insurance Program.
- 18 4. Incorporate hazard awareness and risk reduction principles into the daily activities,  
19 processes, functions, and policies of the community.
- 20 5. Continue to assess and enhance understanding of the extent of our vulnerability to  
21 natural hazards.
- 22 6. Publicize mitigation activities to reduce the area's vulnerability to the identified hazards.

23 Goals form the basis for mitigation actions that will be taken and are not dependent on the  
24 feasibility of implementation. Mitigation actions—which are different than goals—define  
25 strategies that will accomplish the goals and are specific and measurable. The new goals were  
26 developed in coordination with the goals presented in the Commonwealth of Virginia 2018  
27 Hazard Mitigation Plan. The goals were prioritized with one (1) being the most critical.

28 The following are the Goals, for the 2021 LENOWISCO Hazard Mitigation Plan:

- 29 1. Protect the lives, health, and safety of LENOWISCO residents and visitors, maintain  
30 critical societal functions before, during, and after a disaster.
- 31 2. Identify and implement mitigation projects that will minimize a hazard's impact on  
32 existing and future developments, including reducing risk to NFIP repetitive loss and  
33 severe repetitive loss properties.
- 34 3. Incorporate mitigation into existing and future policies, plans, regulations, and laws in  
35 LENOWISCO.
- 36 4. Promote and support a whole community approach to mitigation that encourages  
37 residents, businesses, and public entities to become more disaster resilient. residents,  
38 businesses, and public entities to become more disaster resilient.

39





## 1 1.7.2 Mitigation Strategies and Actions

2 Plan participants assessed hazard mitigation strategies, including strategies from FEMA  
3 documents, strategies from the 2013 Hazard Mitigation Plan, strategies from the 2018  
4 Commonwealth of Virginia Hazard Mitigation Plan, and suggestions from participating  
5 communities. From January-February 2021, virtual meetings were conducted with each  
6 participating jurisdiction to review mitigation strategies based on the hazard analysis for the  
7 jurisdiction. In accordance with 44 CFR §201.6(c)(3)(i), the hazard mitigation strategy shall  
8 include a description of mitigation goals to reduce or avoid long-term vulnerabilities to the  
9 identified hazards. All mitigation actions have an Action Planning & Implementation and  
10 assigned Goal.

11 Following the jurisdiction meeting, the core planning team identified mitigation strategies that  
12 were identified by most jurisdictions. Of these actions, the core planning team discussed and  
13 decided which actions would be best managed at the District level. The core planning team  
14 cross walked all jurisdiction mitigation actions to ensure that each jurisdiction had at least two  
15 (2) mitigation actions per hazard. The mitigation actions can include “all-hazard” actions and  
16 mitigation actions at the District or County level that directly impact the jurisdiction. The priority  
17 mitigation actions correspond with the jurisdiction risk assessment.

18 The mitigation strategies were further evaluated by the steering committee during the final  
19 meeting held on February 18, 2021, resulting in:

- 20 • District-wide new mitigation strategies: 14
- 21 • District-wide ongoing mitigation strategies: 6
- 22 • District-wide completed mitigation strategies: 1
- 23 • District-wide removed mitigation strategies: 2
- 24 • Jurisdiction new mitigation strategies: 101
- 25 • Jurisdiction completed mitigation strategies: 4
- 26 • Jurisdiction removed mitigation strategies: 3

27 This section includes the following:

- 28 • **LENOWISCO Mitigation Strategies/Actions:** District-Wide Mitigation Actions
- 29 • **Municipal Mitigation Strategies/Actions**

30 Each entities' Mitigation Strategies & Actions are organized as follows:

- 31 • **New Mitigation Actions:** New actions identified during this 2021 update process
- 32 • **Ongoing Mitigation Actions:** These ongoing actions were included in the previous  
33 update and have yet to be completed. Some of these actions have no definitive end.  
34 During the 2021 update, these "ongoing" mitigation strategies/actions were modified  
35 and/or amended, as needed, to better define the strategy/action.
- 36 • **Completed Mitigation Actions:** Completed actions since 2013. Completed actions also  
37 included a brief description of the “Resulting Reduction or Limitation of Hazard Impact(s)  
38 Achieved” to show the resulting benefits of implementing the mitigation initiative.

39



1 Mitigation Action Plan

2 The Action Plan is designed to capture important details intended to support the implementation  
 3 of the strategy/action. The Action Plan is pulled into a document with all mitigation actions for  
 4 the District and by jurisdiction to facilitate and encourage the annual review and maintenance of  
 5 each mitigation strategy. The document allows the Lead Agency/Organization to document the  
 6 yearly status of the project prior to and/or during the planning team meeting.

7

TABLE: Mitigation Action Plan Form	
Mitigation Action	
Year Initiated	2021
Applicable Jurisdiction	
Lead Agency/Organization	
Supporting Agencies/Organizations	
Applicable Goal	
Potential Funding Source	
Estimated Cost	
Benefits	
Projected Completion Date	
Priority and Level of Importance	
Actual Completion Date	

8

Recommended Mitigation Action/Implementation Plan and Project Description	
Action/Implementation Plan and Project Description:	

TABLE: STAPLEE Prioritization Table	
Item	Score
<b>Social:</b> Do you agree or disagree that the mitigation action is more likely to: be acceptable to the community; does not adversely affect a particular segment of the population; does not cause relocation of lower-income people, and is compatible with the community's social and cultural values.	<ul style="list-style-type: none"> <li>• Strongly Agree = 5</li> <li>• Agree = 4</li> <li>• Neither Agree or Disagree = 3</li> <li>• Disagree = 2</li> <li>• Strongly Disagree = 1</li> </ul>
<b>Technical:</b> Do you agree or disagree that the mitigation action is technically effective in providing a long-term reduction of losses and has minimal secondary adverse impacts.	<ul style="list-style-type: none"> <li>• Strongly Agree = 5</li> <li>• Agree = 4</li> <li>• Neither Agree or Disagree = 3</li> <li>• Disagree = 2</li> <li>• Strongly Disagree = 1</li> </ul>
<b>Administrative:</b> Do you agree that your jurisdiction/organization has the necessary staffing funding to carry-out this mitigation action.	<ul style="list-style-type: none"> <li>• Strongly Agree = 5</li> <li>• Agree = 4</li> <li>• Neither Agree or Disagree = 3</li> <li>• Disagree = 2</li> <li>• Strongly Disagree = 1</li> </ul>



<p><b>Political:</b> Do you agree or disagree that the mitigation action has the support of the public and stakeholders who have been offered an opportunity to participate in the planning process.</p>	<ul style="list-style-type: none"> <li>• Strongly Agree = 5</li> <li>• Agree = 4</li> <li>• Neither Agree or Disagree = 3</li> <li>• Disagree = 2</li> <li>• Strongly Disagree = 1</li> </ul>
<p><b>Legal:</b> Do you agree or disagree that the jurisdiction or implementing agency has the legal authority to implement and enforce the mitigation action.</p>	<ul style="list-style-type: none"> <li>• Strongly Agree = 5</li> <li>• Agree = 4</li> <li>• Neither Agree or Disagree = 3</li> <li>• Disagree = 2</li> <li>• Strongly Disagree = 1</li> </ul>
<p><b>Economic:</b> Budget constraints can significantly deter the implementation of mitigation actions. Do you agree or disagree that the mitigation action is cost-effective, as determined by a cost-benefit review, and is possible to fund.</p>	<ul style="list-style-type: none"> <li>• Strongly Agree = 5</li> <li>• Agree = 4</li> <li>• Neither Agree or Disagree = 3</li> <li>• Disagree = 2</li> <li>• Strongly Disagree = 1</li> </ul>
<p><b>Environmental:</b> Do you agree or disagree that the mitigation action is sustainable and does not have an adverse effect on the environment, complies with federal, state, and local environmental regulations, and is consistent with the community's environmental goals.</p>	<ul style="list-style-type: none"> <li>• Strongly Agree = 5</li> <li>• Agree = 4</li> <li>• Neither Agree or Disagree = 3</li> <li>• Disagree = 2</li> <li>• Strongly Disagree = 1</li> </ul>
<p><b>Total: maximum possible score is 35</b></p>	

1

TABLE: Mitigated Hazards	
	<b>All Hazards</b>
	Communicable Disease
	Dam Failure
	Drought
	Earthquake
	Flooding
	Karst & Subsidence
	Landslide
	Non-rotational Winds
	Tornado
	Wildfire
	Winter Storm

2

3



## 1 Mitigation Strategy/Action Timeline Parameters

2 While the preference is to provide definitive project completion dates, this is not possible for  
3 every mitigation strategy/action. Therefore, the parameters for the timeline (**Projected**  
4 **Completion Date**) are as follows:

- 5 • **Short Term** = to be completed in 1 to 5 years
- 6 • **Long Term** = to be completed in greater than 5 years
- 7 • **Ongoing** = currently being funded and implemented under existing programs, and/or is  
8 seeking funding and necessary approvals.

## 9 *Mitigation Strategy/Action Estimated Cost*

10 While the preference is to provide definitive costs (dollar figures) for each mitigation  
11 strategy/action, this is not possible for every mitigation strategy/action. Therefore, the estimated  
12 costs for the mitigation initiatives identified in this Plan were identified as high, medium, or low,  
13 using the following ranges:

- 14 • **Low:** less than \$10,000
- 15 • **Medium:** from \$10,000 to \$100,000
- 16 • **High:** greater than \$100,000

## 17 *Mitigation Strategy/Action Prioritization Process*

18 The mitigation strategy/action must be prioritized according to a benefit/cost analysis of the  
19 proposed projects and their associated costs (44 CFR, Section 201.6(c)(3)(iii)). The benefits of  
20 proposed actions were weighed against multiple factors as part of the project prioritization  
21 process. The benefit/cost analysis was not of the detailed variety required by FEMA for project  
22 grant eligibility under the Hazard Mitigation Grant Program (HMGP) and Pre-Disaster Mitigation  
23 (PDM) grant program. A less formal approach was used because some actions/strategies may  
24 not be implemented for up to 10 years, and associated costs and benefits could change  
25 dramatically in that time. The mitigation strategies/actions were prioritized and evaluated as  
26 shown on the individual mitigation action worksheets (using the **STAPLEE** method) for each  
27 recommended mitigation initiative.

28 County and municipal stakeholders evaluated each mitigation strategy/action with the following  
29 categories and questions.

### 30 **Social:**

- 31 • Will the proposed action adversely affect one segment of the population?
- 32 • Will the action disrupt established neighborhoods, break up voting districts, or cause the  
33 relocation of lower-income people?

### 34 **Technical:**

- 35 • How effective is the action in avoiding or reducing future losses?
- 36 • Will it create more problems than it solves?
- 37 • Does it solve the problem or only a symptom?
- 38 • Does the mitigation strategy address continued compliance with the NFIP?



1 **Administrative:**

- 2 • Does the jurisdiction have the capability (staff, technical experts, and/or funding) to
- 3 implement the action, or can it be readily obtained?
- 4 • Can the community provide the necessary maintenance?
- 5 • Can it be accomplished in a timely manner?

6 **Political:**

- 7 • Is there political support to implement and maintain this action?
- 8 • Is there a local champion willing to help see the action to completion?
- 9 • Is there enough public support to ensure the success of the action?
- 10 • How can the mitigation objectives be accomplished at the lowest cost to the public?

11 **Legal:**

- 12 • Does the community have the authority to implement the proposed action?
- 13 • Are the proper laws, ordinances, and resolutions in place to implement the action?
- 14 • Are there any potential legal consequences?
- 15 • Is there any potential community liability?
- 16 • Is the action likely to be challenged by those who may be negatively affected?
- 17 • Does the mitigation strategy address continued compliance with the NFIP?

18 **Economic:**

- 19 • Are there currently sources of funds that can be used to implement the action?
- 20 • What benefits will the action provide?
- 21 • Does the cost seem reasonable for the size of the problem and likely benefits?
- 22 • What burden will be placed on the tax base or local economy to implement this action?
- 23 • Does the action contribute to other community economic goals such as capital
- 24 improvements or economic development?
- 25 • What proposed actions should be considered but be “tabled” for implementation until
- 26 outside sources of funding are available?

27 **Environmental:**

- 28 • How will this action affect the environment (land, water, endangered species)?
- 29 • Will this action comply with local, state, and federal environmental laws and regulations?
- 30 • Is the action consistent with community environmental goals?

31 Priority was assessed by requesting that every new mitigation action submitted by departments  
32 and municipalities go through a ranking process (for each of the prioritization factors), which  
33 was a numbering system from 1 to 5 with 1 being less important and 5 is more important.

34 Each of the participating communities was invited to participate in a series of workshops in  
35 which goals, objectives, and strategies were discussed, identified, updated, and prioritized.  
36 Each participant in this session was provided with a number of resources to help them identify  
37 relevant mitigation strategies including the [FEMA Mitigation Ideas Handout](#).

38 All potential strategies that arose through this process are included in this Plan. A final draft of  
39 the Plan was presented to all stakeholders to allow them to provide final edits and approval of  
40 the strategies and their priority.





1 2021 Hazard Mitigation Priorities

2 The implementation of the mitigation plan is critical to the overall success of the mitigation  
3 planning process. The first step is to decide, based upon many factors, which action will be  
4 undertaken first. To pursue the top priority first, the analysis and prioritization of the  
5 strategies/actions are important. Some actions may occur before the mitigation strategies  
6 representing the highest priority due to financial, engineering, environmental, permitting, and  
7 site control issues.

8 Since 2013, the LENOWISCO Planning District and the participating jurisdictions have  
9 experienced significant changes in staffing and capacity for the Emergency Management  
10 program. In recent years, the Emergency Management program has been a growing priority for  
11 both the District and the jurisdictions. In the years coming, the LENOWISCO Planning District  
12 and the participating jurisdictions have made mitigation planning and action a top priority.

13 The planning team prioritized mitigation actions based on the STAPLEE (Social, Technical,  
14 Administrative, Political, Legal, Economic, and Environmental) criteria, explained in the  
15 Mitigation Strategies and Actions section, and discussion with the planning committees.  
16 Mitigation strategies/actions with the highest scores represent those mitigation initiatives that  
17 represent the highest priority. In addition to the STAPLEE Method, the steering committee  
18 identified those strategies/actions that represented the greatest importance and priority to the  
19 District. It should be noted that, although the STAPLEE Method provides a standardized  
20 process for assigning priority/importance across all participating jurisdictions, there may be  
21 additional factors and considerations that elevate the status of a mitigation strategy/action.  
22 Therefore, the steering committee's input is also an important consideration in this process. In  
23 addition to assigning priorities for the new projects, priorities for the previous projects were  
24 evaluated and updated.



District-Wide Actions 1-4							
Action #	New/Existing	Status	Hazard(s) Mitigated	Mitigation Action/Strategy	Lead Agency	Support Agencies	Goal
1	New	Started in some jurisdictions	All-Hazard	Develop and deliver a Community Emergency Response Team (CERT) program for the LENOWISCO District and recruit members from all participating jurisdictions.	Local Emergency Operations Coordinators	County and municipal fire and police departments	4 - Whole Community
2	New	Started in some jurisdictions	All-Hazard	Certify and/or maintain participation in StormReady Certification Program for all LENOWISCO District communities.	Local Emergency Operations Coordinators	None	3 - Polices & Plans
3	New	Not Started	All-Hazard	Ensure each jurisdiction has an updated sheltering plan that includes disease spread prevention, necessary supplies, methods of transportation, and priority populations for welfare checks.	LENOWISCO Health District	Local Emergency Operations Coordinators	1 - Protection
4	New	Started in some jurisdictions	All-Hazard	Ensure each jurisdiction has a Continuity of Operations Plan that includes both natural hazards and epidemic/pandemic considerations.	County Administrators; Town Managers	Local Emergency Operations Coordinators	3 - Policies & Plans 4 - Whole Community



District-Wide Actions 1-4							
Action #	Funding Source	Estimated Cost	Benefits	Priority	Timeline	Action Planning & Implementation	STAPLEE Score
1	FEMA, VDEM, Local funds,	Low	Medium	High	Short-Term	Provide information about the CERT program and 72-hour preparedness to residents through local publications, neighborhood organizations, churches, etc.; Identify the needs of local CERT programs and attain funding to purchase CERT supplies	28
2	Local funds	Low	Medium	High	Ongoing	Identify and outline local requirements for StormReady certification; develop an action plan to certify or maintain certification as appropriate using a planning calendar with identified goals, objectives and benchmark dates.	28
3	Virginia Department of Health, FEMA, DHHS	Medium	High	Medium	Short-Term	Review and update existing shelter plans to ensure they address new practices based on COVID-19. Jurisdictions without plans will work to identify funding streams to assist with plan development, apply for grants as appropriate, and work toward developing plans.	15
4	FEMA	Medium	Medium	High	Short-Term	Review and update existing continuity plans to ensure they address any new objectives based on COVID-19. Jurisdictions without plans will work to identify funding streams to assist with plan development, apply for grants as appropriate, and work toward developing plans.	28



District-Wide Actions 5-8							
Action #	New/Existing	Status	Hazard(s) Mitigated	Mitigation Action/Strategy	Lead Agency	Support Agencies	Goal
5	New	In Progress	Communicable Disease	Update the LENOWISCO Health District Pandemic and Communicable Disease Plan using lessons learned from the COVID-19 pandemic.	LENOWISCO Health District	Local Emergency Operations Coordinators	3 - Polices & Plans
6	New	Not Started	Communicable Disease	Identify local and regional mitigation actions through the exercise of the LENOWISCO Pandemic and Communicable Disease Plan and development of a COVID-19 After Action Report.	LENOWISCO Health District	Local Emergency Operations Coordinators	3 - Polices & Plans
7	New	Not Started	Earthquake	Initiate a benefit-cost analysis of seismic improvements across the LENOWISCO District to determine priority retrofitting needs.	Building and Zoning Officers	Local Emergency Operations Coordinators; Virginia DMME	2 - Mitigation
8	Existing	In Progress	Flooding	Ensure continued compliance in the National Flood Insurance Program (NFIP) through enforcement of local floodplain management ordinances and take steps to participate in the Community Rating System (CRS).	Local Floodplain Coordinators	Local Emergency Operations Coordinators	3 - Polices & Plans



District-Wide Actions 5-8							
Action #	Funding Source	Estimated Cost	Benefits	Priority	Timeline	Action Planning & Implementation	STAPLEE Score
5	Virginia Department of Health, FEMA, DHHS	Medium	Medium	High	Short-Term	Develop an after-action report on the challenges and successes from the COVID-19 pandemic. Convene a 'whole community' group to inform a county-wide plan that addresses mitigation, prevention, and operational changes.	28
6	Virginia Department of Health, FEMA, DHHS	Medium	Medium	Medium	Short-Term	After existing plans are updated or new plans developed, seek funding sources and exercise the plans. Develop an After-Action Report/Implementation Plan and identify mitigation actions through the exercise process.	21
7	USGS, Earthquake Hazards Program Grant, HMA Funds	Medium	Medium	Low	Short-Term	Seek funding for Benefit-Cost Analyses. Once funding is secure, conduct analyses on vulnerable structures and infrastructure.	13
8	Local funds	Low	Medium	High	Ongoing	Maintain NFIP and CRS compliance in all jurisdictions. For jurisdictions not currently participating the CRS, take steps to determine the process for participation, seek funding as appropriate, and document progress toward participation.	28





**District-Wide Actions 9-13**

Action #	New/Existing	Status	Hazard(s) Mitigated	Mitigation Action/Strategy	Lead Agency	Support Agencies	Goal
9	New	Not Started	Karst	Develop a public awareness and education campaign for local property owners located in karst-terrain or near/on abandoned mining property. Offer information on mine water run-off and opportunities for property owners to improve drainage systems.	Local Emergency Operations Coordinators	Virginia DMME	4 - Whole Community
10	New	Not Started	Karst	Partner with the Virginia Department of Mines, Minerals, and Energy to identify, prioritize, implement, and maintain drainage projects near mines.	Building and Zoning Officers	Virginia DMME	2 - Mitigation
11	New	Not Started	Wildfire	Develop a LENOWISCO Community Wildfire Protection Plan with specific regional and local actions for wildfire mitigation.	LENOWISCO Planning District Commission	Local Fire Departments, U.S. Forest Service; VDF	3 - Polices & Plans
12	New	Not Started	Wildfire	Promote public awareness campaigns for individual property owners living in the Wildland/Urban Interface (WUI), including participation in the FireWise program.	Local Fire Departments	U.S. Forest Service; VDF	4 - Whole Community
13	New	Not Started	Wildfire	Identify vulnerable structures and apply for funding to implement wildfire mitigation projects. These are projects to mitigate the risk to at-risk structures and associated loss of life from the threat of future wildfire through: Defensible Space for Wildfire; Application of Ignition-resistant Construction; and Hazardous Fuels Reduction.	Local Fire Departments	U.S. Forest Service; VDF	1 - Protection



District-Wide Actions 9-13							
Action #	Funding Source	Estimated Cost	Benefits	Priority	Timeline	Action Planning & Implementation	STAPLEE Score
9	USGS, Earthquake Hazards Program Grant; HMA Funds, Local funds	Medium	Low	Medium	Short-Term	Work with DMME and USGS to seek funding and best practice public awareness campaigns for karst terrain. Implement best practice programs through awarded grant support, when available.	23
10	Virginia DMME, VDEM, EPA	High	Low	Medium	Ongoing	Work with DMME to identify and prioritize project sites. Work with property owners to grant easements for projects. Secure funding for town maintenance of projects.	24
11	Virginia Department of Forestry	Medium	Medium	High	Short-Term	Seek grant funding and assistance to develop a CWPP for the District.	29
12	Virginia Department of Forestry	Medium	Low	Medium	Ongoing	Work with state, and federal forestry offices to identify best practice public awareness campaigns and conduct those campaigns in the local jurisdictions.	23
13	Virginia Department of Forestry, HMGF, PDM	Medium	High	Medium	Ongoing	Locate and map structures in the WUI areas. Conduct vulnerability assessment on those structures and determine the best mitigation actions to protect them. Apply for funding based on the outcomes of the assessments.	25



City of Norton Actions 1-5

Action #	New/Existing	Status	Hazard(s) Mitigated	Mitigation Action/Strategy	Lead Agency	Support Agencies	Goal
1	New	In Progress	All-Hazard	Secure funding to purchase a back-up generator for the Josephine Wastewater Pump Station and other critical infrastructure priority sites as identified.	Public Works	CNW Regional Wastewater Treatment Authority	1 - Protection 4 - Whole Community
2	New	Not Started	Drought	Ensure adequate back-up potable water supplies to supplement municipal water sources through 1) purchase of portable storage tanks for potable water, including a specific back-up water supply for the regional dialysis center in Norton; and 2) securing contracts with water suppliers.	Public Works	Norton Emergency Management, Fresenius Kidney Care	1 - Protection
3	New	In Progress	Flooding	Update the preliminary design and cost assessment and secure funding for a complete stormwater system replacement at three identified drainage basins experiencing significant localized flooding and damage (7th Street Basin, 10/11th Streets Drainage Basin, and Main Line Trunk) and others as identified.	Public Works	Emergency Management	2 - Mitigation
4	New	Update	Dam Failure	Update the inundation study for the Norton Reservoir Upper and Lower Dams.	Public Works	Emergency Management	1 - Protection
5	New	Not Started	Dam Failure	Conduct an annual tabletop exercise for a dam failure event.	Public Works	Emergency Management	1 - Protection 3 - Plans & Policies



City of Norton Actions 1-5							
Action #	Funding Source	Estimated Cost	Benefits	Priority	Timeline	Action Planning & Implementation	STAPLEE Score
1	FEMA	Medium	Medium	Medium	Short-Term	Seek grant funding and assistance.	18
2	FEMA	Medium	High	High	Short-Term	Identify priority locations and water service vulnerabilities. Secure funding for storage tanks. Identify potential contractors for emergency water supply.	27
3	FEMA	High	High	High	Short-Term	Seek grant funding and assistance for the assessment update.	28
4	FEMA, USACE, VA DCR	Medium	High	High	Ongoing	Seek grant funding and assistance to update previous inundation studies. Identify and recruit priority participants that would be involved in resident notification and evacuation. Seek funding and technical assistance to coordinate and manage a table-top exercise. Develop an after-action report to identify and implement necessary improvements.	30
5	Local funds	Low	Medium	Low	Ongoing		14



City of Norton Actions 6-11							
Action #	New/ Existing	Status	Hazard(s) Mitigated	Mitigation Action/Strategy	Lead Agency	Support Agencies	Goal
6	New	Not Started	Earthquake Landslide	Initiate a benefit-cost and alternatives analysis for relocating/replacing gas chlorine storage at the Norton Water Treatment Plant.	Public Works	Wise County PSA	2 - Mitigation 4 - Whole Community
7	New	Not Started	Landslide	Identify and scope mitigation projects for potential landslide areas on critical roadways in/out of Norton.	VDOT	Public Works	2 - Mitigation
8	New	Not Started	Non- Rotational Wind Tornado Winter Storm	Initiate an assessment of necessary improvements to the Norton Community Center to serve as a designated tornado and severe weather shelter.	Emergency Management	Parks and Recreation, American Red Cross	1 - Protection
9	New	Not Started	Non- Rotational Wind Tornado Winter Storm	Secure sufficient sheltering supplies and a back-up generator for the Norton Community Center.	Emergency Management	Parks and Recreation, American Red Cross	1 - Protection 4 - Whole Community
10	New	Not Started	Non- Rotational Wind Tornado Winter Storm	Initiate a benefit-cost analysis of building storm shelters/safe rooms at various mobile home parks across Norton.	Emergency Management	Building and Zoning	1 - Protection
11	New	Not Started	Wildfire	Secure funding for increased wildland training and protective equipment.	Norton Fire Department	USFS, VA Department of Forestry	1 - Protection





City of Norton Actions 6-11							
Action #	Funding Source	Estimated Cost	Benefits	Priority	Timeline	Action Planning & Implementation	STAPLEE Score
6	EPA, FEMA,	Medium	Medium	Medium	Short-Term	Seek funding for Benefit-Cost Analyses. Once funding is secure, conduct analyses on design and scope of alternatives.	21
7	VDOT, USDOT, FHWA, USFS, VA DOF	High	Medium	Medium	Ongoing	Review historic data on landslide events affecting roadways in partnership with VDOT. Determine priority mitigation actions. Determine authority responsible for improvements. Secure funding for projects as needed.	21
8	FEMA, DHHS	Medium	Medium	High	Short-Term	Identify shelter capacity and safety features based on sheltering plan and federal, state, and local regulations.	28
9	FEMA, DHHS, VDOH	High	High	High	Short-Term	Review and update existing shelter plans to ensure they address new practices based on COVID-19. Secure funding for additional sheltering supplies as identified through plan updates.	28
10	FEMA, VDEM, Local funds	Medium	Medium	Medium	Short-Term	Seek funding for Benefit-Cost Analyses. Once funding is secure, conduct analyses on design and scope of shelters/safe rooms.	21
11	FEMA AFG	High	Medium	Medium	Short-Term	Identify training and equipment needs. Secure funding for improvements.	22



City of Norton Actions 12-14							
Action #	New/ Existing	Status	Hazard(s) Mitigated	Mitigation Action/Strategy	Lead Agency	Support Agencies	Goal
12	New	Not Started	Winter Storm	Secure resources for transporting dialysis patients to/from the regional dialysis center (Fresenius Kidney Care) during severe weather events.	Emergency Management	Fresenius Kidney Care; Norton Fire Department, Kidney Community Emergency Response (KCER) Program	1 - Protection
13	New	Not Started	Winter Storm	Secure a back-up generator for at least one gas station in Norton, and other locations to be identified, to serve as a back-up fuel supply for essential government vehicles.	Public Works	Emergency Management, Police, and Fire Departments	1 - Protection
14	New	Not Started	Winter Storm	Initiate an alternatives analysis to address salt storage and supply needs, ideally in partnership with VDOT.	Public Works	VDOT	1 - Protection 3 - Plans & Policies



City of Norton Actions 12-14

Action #	Funding Source	Estimated Cost	Benefits	Priority	Timeline	Action Planning & Implementation	STAPLEE Score
12	DHHS, local funds	Medium	Medium	Medium	Ongoing	Identify vulnerable groups and geographic extent for transportation. Recruit a volunteer base and/or transportation options. Develop a plan and communication system.	19
13	FEMA	High	Medium	Medium	Short-Term	Scope the costs for purchase and installment. Prioritize sites based on community and resident vulnerability, site size, and secured resources. Identify and secure funding.	21
14	VDOT, USDOT, FHWA	Medium	Low	Low	Short-Term	Assess capacity and design needs. Scope alternatives and costs. Secure funding for purchase.	14



Lee County Actions 1-4

Action #	New/ Existing	Status	Hazard(s) Mitigated	Mitigation Action/Strategy	Lead Agency	Support Agencies	Goal
1	New	Not Started	All-Hazard	Develop and deliver a public education and awareness program of mitigation strategies, including limiting the spread of communicable diseases.	Emergency Management	LENOWISCO Health District; community-based and faith-based organizations	4 - Whole Community
2	New	Not Started	All-Hazard	Develop an inventory of at-risk public buildings and infrastructure and prioritize mitigation projects based on those providing the most benefit (at the least cost) to the County and residents.	Public Works	Emergency Management	2 - Mitigation 4 - Whole Community
3	New	Not Started	Drought	Establish sufficient public water system interconnects between communities and across county and state lines.	Lee County PSA	Public Works	1 - Protection
4	New	Not Started	Earthquake Flooding Non-Rotational Winds Tornado Winter Storm	Purchase at least three generators for emergency shelters and ensure all shelters are wired for portable generators (including any locations in Pennington Gap).	Emergency Management	Lee County Public Schools	1 - Protection



Lee County Actions 1-4

Action #	Funding Source	Estimated Cost	Benefits	Priority	Timeline	Action Planning & Implementation	STAPLEE Score
1	VDEM, VDOH, local funds	Low	Low	Medium	Short-Term	Identify priority populations for outreach and appropriate platforms and communication tools. Work with state agencies to seek funding and best practice public awareness campaigns. Implement best practice programs through awarded grant support, when available.	22
2	HMA, USACE	Medium	Medium	Medium	Short-Term	Develop an inventory of un-reinforced masonry buildings to target for mitigation; Develop an inventory of commercial and public buildings in need of flood, windstorm, and earthquake mitigation; Identify at-risk bridges for flood and earthquake hazards, identify enhancements, and implement projects needed to reduce the risks; and Review and improve utility operations and services to mitigate for natural hazards.	19
3	Local funds	Medium	Medium	Medium	Ongoing	Prioritize additional water sources. Outreach to other PSAs and municipal providers to draft an interconnect agreement. Revise and revisit as needed.	19
4	FEMA	High	Medium	High	Short-Term	Scope the costs for purchase and installment. Prioritize sites based on community and resident vulnerability, site size, and secured resources. Identify and secure funding.	27





**Pennington Gap (Lee County) Actions 1-4**

Action #	New/ Existing	Status	Hazard(s) Mitigated	Mitigation Action/Strategy	Lead Agency	Support Agencies	Goal
1	New	Not Started	All-Hazard	Develop and deliver a public education and awareness program of mitigation strategies, including limiting the spread of communicable diseases.	Emergency Management	LENOWISCO Health District; community-based and faith-based organizations	3 - Plans & Policies 4 - Whole Community
2	New	Not Started	All-Hazard	Develop an inventory of at-risk public buildings and infrastructure and prioritize mitigation projects based on those providing the most benefit (at the least cost) to the Town and residents.	Public Works	Emergency Management	2 - Mitigation 4 - Whole Community
3	New	Not Started	Communicable Disease	Establish an emergency shelter for those experiencing homelessness that meets social distancing standards.	Social Services	Emergency Management	1 - Protection
4	New	Not Started	Earthquake Flooding Non-Rotational Winds Tornado Winter Storm	Work with the County to purchase at least three generators for emergency shelters and ensure all shelters are wired for portable generators (including any locations in Pennington Gap).	Emergency Management	Lee County Public Schools	1 - Protection



Pennington Gap (Lee County) Actions 1-4							
Action #	Funding Source	Estimated Cost	Benefits	Priority	Timeline	Action Planning & Implementation	STAPLEE Score
1	VDEM, VDOH, local funds	Low	Low	Medium	Short-Term	Identify priority populations for outreach and appropriate platforms and communication tools. Work with state agencies to seek funding and best practice public awareness campaigns. Implement best practice programs through awarded grant support, when available.	20
2	HMA, USACE	Medium	Medium	Medium	Short-Term	Develop an inventory of un-reinforced masonry buildings to target for mitigation; Develop an inventory of commercial and public buildings in need of flood, windstorm, and earthquake mitigation; Identify at-risk bridges for flood and earthquake hazards, identify enhancements, and implement projects needed to reduce the risks; and Review and improve utility operations and services to mitigate for natural hazards.	18
3	DHHS	Medium	Medium	Medium	Short-Term	Identify service population needs and managing organization capacity (CBO, faith-based org, city-operated, etc.) Scope project design and cost. Secure funding for construction and operations.	18
4	FEMA	High	Medium	High	Short-Term	Scope the costs for purchase and installment. Prioritize sites based on community and resident vulnerability, site size, and secured resources. Identify and secure funding.	28



Pennington Gap (Lee County) Actions 5-8							
Action #	New/Existing	Status	Hazard(s) Mitigated	Mitigation Action/Strategy	Lead Agency	Support Agencies	Goal
5	New	Not Started	Flooding	Initiate an impact assessment for the potential tunnel failure of Wallen Creek.	Public Works	VDOT	2 - Mitigation
6	New	Not Started	Non-Rotational Wind Tornado Winter Storm	Conduct a survey to estimate the costs of burying utility lines.	Public Utility Companies	Public Works	1 - Protection
7	New	Not Started	Wildfire	Secure a new apparatus for the local fire department that can respond to wildfire/grassfire events, as well as additional protective equipment.	Pennington Gap Fire Department	Town Administrator/ Clerk	1 - Protection 4 - Whole Community
8	New	Not Started	Winter Storm	Secure additional heavy equipment for snow removal operations.	Public Works	VDOT	1 - Protection



Pennington Gap (Lee County) Actions 5-8							
Action #	Funding Source	Estimated Cost	Benefits	Priority	Timeline	Action Planning & Implementation	STAPLEE Score
5	VDOT	Medium	Medium	Medium	Short-Term	Scope the project cost and secure funding for an assessment. Scope the cost and design of structural mitigation.	22
6	FEMA	Medium	Medium	Low	Short-Term	Secure funding and a contractor for survey estimate. Conduct survey and identify priority areas for project investment. Consider a Benefit-Cost Analysis of burying powerlines.	11
7	U.S. Fire Administration, USFS, VA Department of Forestry	High	Medium	Medium	Short-Term	Complete an assessment of equipment costs. Secure funding for purchase.	23
8	FEMA	High	Low	Low	Long-Term	Scope equipment needs and cost. Identify and secure funding.	14



**Scott County Actions 1-4**

Action #	New/Existing	Status	Hazard(s) Mitigated	Mitigation Action/Strategy	Lead Agency	Support Agencies	Goal
1	New	New	All-Hazard	Develop an inventory of at-risk public buildings and prioritize infrastructure and prioritize mitigation projects based on those providing the most benefit (at the least cost) to the County and residents.	Public Works	Emergency Management	2 - Mitigation 4 - Whole Community
2	New	In Progress	All-Hazard	Develop and implement outreach and educational programs aimed at mitigating and reducing the risk of natural hazards, particularly those residing in flood-prone areas, mobile homes subject to high winds and tornadoes, and residents at-risk to extreme weather and/or communicable disease.	Emergency Management	Community-based and faith-based organizations	4 - Whole Community
3	New	New	Dam Failure	Install an outdoor warning system for residents within the Bark Camp Dam inundation area.	Emergency Management	DCR, USACE	1 - Protection
4	New	New	Drought	Expand the public water supply through Scott County Public Service Authority to provide a reliable and safe water supply to residents using wells/springs.	Scott County PSA	Public Works	1 - Protection





Scott County Actions 1-4

Action #	Funding Source	Estimated Cost	Benefits	Priority	Timeline	Action Planning & Implementation	STAPLEE Score
1	HMA, USACE	Medium	Medium	Medium	Short-Term	Develop an inventory of un-reinforced masonry buildings to target for mitigation: Develop an inventory of commercial and public buildings in need of flood, windstorm, and earthquake mitigation; identify at-risk bridges for flood and earthquake hazards, identify enhancements, and implement projects needed to reduce the risks; and Review and improve utility operations and services to mitigate for natural hazards.	21
2	VDEM, Local funds	Medium	Medium	Medium	Ongoing	Identify priority populations for outreach and appropriate platforms and communication tools. Work with state agencies to seek funding and best practice public awareness campaigns. Implement best practice programs through awarded grant support, when available.	25
3	Virginia DCR, FEMA	Medium	High	Medium	Short-Term	Develop a project scope based on the inundation area that includes the number and type of signals/structures. Secure funding. Install warning system. Conduct an outreach and awareness campaign to notify residents of the new system.	22
4	Local funds	High	Medium	Medium	Ongoing	Prioritize additional water sources. Scope project costs, including pump installation and equipment. Secure funding for project.	22



**Scott County Actions 5-9**

Action #	New/Existing	Status	Hazard(s) Mitigated	Mitigation Action/Strategy	Lead Agency	Support Agencies	Goal
5	New	New	Earthquake Flooding Non-Rotational Winds Tornado Winter Storm	Purchase at least three generators for emergency shelters and ensure all shelters are wired for portable generators (including any locations in Gate City).	Emergency Management	Scott County Public Schools	1 - Protection
6	New	New	Flooding	Conduct a water study to document the need for improved storm drain infrastructure.	Public Works	Floodplain Coordinator	2 - Mitigation
7	New	New	Landslide	Identify and scope mitigation projects for potential landslide areas on critical roadways.	Virginia Department of Transportation	Public Works	2 - Mitigation
8	New	New	Wildfire	Explore changes to building and zoning code to encourage fire protective development strategies.	Building & Zoning	Fire Department	2 - Mitigation
9	New	New	Winter Storm	Secure funding for contract plowing/road clearing services to supplement low-priority routes maintained by VDOT.	Public Works	VDOT	1 - Protection



Scott County Actions 5-9

Action #	Funding Source	Estimated Cost	Benefits	Priority	Timeline	Action Planning & Implementation	STAPLEE Score
5	FEMA, DHHS	High	Medium	High	Short-Term	Scope the costs for purchase and installment. Prioritize sites based on community and resident vulnerability, site size, and secured resources. Identify and secure funding.	28
6	FEMA	Medium	Medium	Medium	Short-Term	Scope project extent and costs. Identify potential contractors. Secure funding for project execution.	24
7	VDOT, USDOT, FHWA, USFS, VA DOF	High	Medium	Low	Long-Term	Review historic data on landslide events affecting roadways in partnership with VDOT. Determine priority mitigation actions. Determine authority responsible for improvements. Secure funding for projects as needed.	14
8	Local funds	Low	Medium	Low	Long-Term	Review best practices in code and ordinances for fire protective development. Prioritize and recommend changes.	13
9	VDOT	Medium	Medium	Low	Ongoing	Scope project extent and costs. Identify potential contractors. Secure funding for contract support.	13



**Gate City (Scott County) Actions 1-4**

Action #	New/Existing	Status	Hazard(s) Mitigated	Mitigation Action/Strategy	Lead Agency	Support Agencies	Goal
1	New	New	All-Hazard	Develop an inventory of at-risk public buildings and infrastructure and prioritize mitigation projects based on those providing the most benefit (at the least cost) to the County and residents.	Public Works	Emergency Management	2 - Mitigation 4 - Whole Community
2	New	In Progress	Earthquake Flooding Non-Rotational Winds Tornado Winter Storm	Advance property mitigation as identified in the 2019 Gate City Housing Needs Assessment, including homes identified in the floodway and vacant/abandoned properties.	Community Development; Building & Zoning	Floodplain Coordinator	2 - Mitigation
3	New	New	Earthquake Flooding Non-Rotational Winds Tornado Winter Storm	Create a strategy to inspect and document vacant buildings that may pose a threat to public safety during a hazard event.	Building & Zoning	Public Works	2 - Mitigation 3 - Plans & Policies
4	New	New	Earthquake Flooding Non-Rotational Winds Tornado Winter Storm	Work with the County to purchase at least three generators for emergency shelters and ensure all shelters are wired for portable generators (including any locations in Gate City).	Emergency Management	Scott County Public Schools	1 - Protection



Gate City (Scott County) Actions 1-4

Action #	Funding Source	Estimated Cost	Benefits	Priority	Timeline	Action Planning & Implementation	STAPLEE Score
1	HMA, USACE	Medium	Medium	Medium	Short-Term	Develop an inventory of un-reinforced masonry buildings to target for mitigation; Develop an inventory of commercial and public buildings in need of flood, windstorm, and earthquake mitigation; Identify at-risk bridges for flood and earthquake hazards, identify enhancements, and implement projects needed to reduce the risks; and Review and improve utility operations and services to mitigate for natural hazards.	24
2	FEMA, VDEM	High	High	High	Ongoing	Provide information to owners of identified properties on acquisition/buy-out program options. Secure funding for property acquisition/demolition/relocation efforts. Secure funding for improvements for individual properties.	29
3	Local funds	Low	Medium	High	Short-Term	Review vacant/abandoned properties identified in the 2019 housing needs assessment. Prioritize those that require inspection or immediate mitigation based on public safety needs. Secure funding to address mitigation needs.	29
4	FEMA	High	Medium	High	Short-Term	Scope the costs for purchase and installment. Prioritize sites based on community and resident vulnerability, site size, and secured resources. Identify and secure funding.	29





**Gate City (Scott County) Actions 5-8**

Action #	New/Existing	Status	Hazard(s) Mitigated	Mitigation Action/Strategy	Lead Agency	Support Agencies	Goal
5	New	In Progress	Flooding	Advance mitigation action items identified in the watershed survey to determine the source of flooding at Grogan Park, conducted by the Army Corps of Engineers.	Public Works	Army Corps of Engineers	2 - Mitigation
6	New	Not Started	Flooding	Install a back-up generator at the Gate City water treatment plant and in the water distribution system.	Public Works	VDH	1 - Protection
7	New	New	Flooding	Initiate culvert improvements or replacement at the East Jackson Street and Jones Street intersection.	Public Works	Floodplain Coordinator	2 - Mitigation
8	New	New	Winter Storm	Secure additional heavy equipment for snow removal operations.	Public Works	Emergency Management	1 - Protection



Gate City (Scott County) Actions 5-8							
Action #	Funding Source	Estimated Cost	Benefits	Priority	Timeline	Action Planning & Implementation	STAPLEE Score
5	FEMA, VDEM, local funds	High	High	High	Ongoing	Complete the watershed survey in partnership with the Army Corps of Engineers. Prioritize needed mitigation actions identified through survey. Scope project costs and design. Secure funding to complete projects.	31
6	FEMA, local funds	High	Medium	High	Short-Term	Scope the costs for purchase and installment. Identify and secure funding.	30
7	VDOT, FEMA	High	High	High	Short-Term	Scope the project cost and design. Identify and secure funding.	29
8	FEMA	High	Low	Low	Long-Term	Scope equipment needs and cost. Identify and secure funding.	14



Wise County Actions 1-4							
Action #	New/Existing	Status	Hazard(s) Mitigated	Mitigation Action/Strategy	Lead Agency	Support Agencies	Goal
1	New	Not Started	All-Hazard	Develop an inventory of at-risk public buildings and infrastructure and prioritize mitigation projects based on those providing the most benefit (at the least cost) to the County and residents.	Wise County Public Works	Emergency Management	2 - Mitigation 4 - Whole Community
2	New	In Progress	All-Hazard	Develop and implement outreach and educational programs aimed at mitigating and reducing the risk of natural hazards. Add specific hazards and target populations here.	Emergency Management	Community-based and faith-based organizations	4 - Whole Community
3	New	Not Started	Dam Failure	Update mapping of permitted and unpermitted coal slurry ponds throughout the county.	Wise County Geographic Information Officer	DMME, DCR	2 - Mitigation
4	New	Not Started	Drought	Ensure adequate back-up potable water supplies to supplement municipal water sources through 1) purchase of portable storage tanks for potable water, including a specific back-up water supply for the regional dialysis center in Norton; and 2) securing contracts with water suppliers.	Wise County Emergency Management	Wide County Public Works	1 - Protection



Wise County Actions 1-4

Action #	Funding Source	Estimated Cost	Benefits	Priority	Timeline	Action Planning & Implementation	STAPLEE Score
1	HMA, USACE	Medium	Medium	Medium	Short-Term	Develop an inventory of un-reinforced masonry buildings to target for mitigation; Develop an inventory of commercial and public buildings in need of flood, windstorm, and earthquake mitigation; Identify at-risk bridges for flood and earthquake hazards; identify earthquake hazards; identify enhancements; and implement projects needed to reduce the risks; and Review and improve utility operations and services to mitigate for natural hazards.	20
2	VDEM, Local funds	Medium	Medium	Medium	Ongoing	Identify priority populations for outreach and appropriate platforms and communication tools. Work with state agencies to seek funding and best practice public awareness campaigns. Implement best practice programs through awarded grant support, when available.	23
3	FEMA BRIC, HMA, HMGP, EPA, VA DEQ	Medium	Low	Low	Short-Term	Create an updated map and identify potential outflow risks, including abandoned mine shafts, karst areas, and underground water sources. Identify downstream vulnerabilities and risks associated with slurry contaminates.	14
4	FEMA	Medium	Medium	High	Short-Term	Identify priority locations and water service vulnerabilities. Secure funding for storage tanks. Identify potential contractors for emergency water supply.	27



Wise County Actions 5-11

Action #	New/ Existing	Status	Hazard(s) Mitigated	Mitigation Action/Strategy	Lead Agency	Support Agencies	Goal
5	Existing	In Progress	Earthquake Flooding Non-Rotational Winds Tornado Winter Storm	Purchase generators for emergency shelters at JW Adams Elementary School (Pound), Union Elementary (Big Stone Gap), Wise Elementary School, and other locations as identified. Ensure all shelters are wired for portable generators.	Wise County Emergency Management	Wise County Public Schools	1 - Protection
6	New	Not Started	Flooding	Identify and prioritize upgrades to sewer and water service infrastructure located in flood-prone areas, including those that cross creeks.	Wise County Public Works	VDH	1 - Protection
7	New	Not Started	Karst	Investigate the development and implementation of a karst terrain ordinance in the county.	Wise County Zoning and Development	Local Building & Zoning Officers	3 - Polices & Plans
8	New	In Progress	Karst	Secure funding to repair the sinkhole on Knowledge Drive in partnership with Town of Pound.	Public Works	VDOT	2 - Mitigation
9	New	Not Started	Landslide	Initiate a geotechnical impact assessment of the Big Stone Gap Water Treatment Plan from the 2019 Big Cherry Landslide.	Public Works	Wise County Public Service Authority	2 - Mitigation
10	New	Not Started	Landslide	Investigate the development and implementation of a landslide ordinance to prevent further development/construction in landslide areas of the county.	Wise County Zoning and Development	Local Building & Zoning Officers	3 - Polices & Plans
11	New	Not Started	Winter Storm	Secure additional heavy equipment for snow removal operations.	Wise County Public Works	Norton and Big Stone Gap Public Works	1 - Protection





Wise County Actions 5-11

Action #	Funding Source	Estimated Cost	Benefits	Priority	Timeline	Action Planning & Implementation	STAPLEE Score
5	FEMA, local funds	High	Medium	High	Short-Term	Scope the costs for purchase and installment. Prioritize sites based on community and resident vulnerability, site size, and secured resources. Identify and secure funding.	28
6	FEMA, local funds, VDEM, VPH	High	Medium	Low	Long-Term	Review best practices in code and ordinances for development in karst terrain. Prioritize and recommend changes.	14
7	Local funds	Low	Low	Low	Short-Term	Determine where karst areas and future development may intersect; study the feasibility and impacts of ordinances.	12
8	VDOT	High	High	High	Short-Term	Scope project extent and costs. Identify potential contractors. Secure funding for project execution.	24
9	Virginia DCR, FEMA	Medium	High	High	Short-Term	Identify project scope and cost. Identify and recruit technical experts. Secure funding and assistance.	25
10	Local funds	Low	Low	Low	Short-Term	Review best practices in code and ordinances for development in highly susceptible landslide areas. Prioritize and recommend changes.	14
11	FEMA, VDOT	High	Medium	Medium	Short-Term	Scope equipment needs and cost. Identify and secure funding.	22



**Big Stone Gap (Wise County) Actions 1-5**

Action #	New/Existing	Status	Hazard(s) Mitigated	Mitigation Action/Strategy	Lead Agency	Support Agencies	Goal
1	New	Not Started	All-Hazard	Ensure an effective mass notification system for residents for events within town limits.	Emergency Management	Police and Fire departments	4 - Whole Community
2	New	In Progress	Drought	Ensure adequate back-up potable water supplies to supplement municipal water sources through 1) purchase of portable storage tanks for potable water; and 2) securing a microfiltration system for potable water.	Public Works	Emergency Management	1 - Protection
3	New	In Progress	Earthquake Flooding Non-Rotational Winds Tornado Winter Storm	Purchase generators for emergency shelters at JW Adams Elementary School (Town of Pound), Union Elementary (Big Stone Gap), Wise Elementary School, and other locations as identified. Ensure all shelters are wired for portable generators.	Wise County Emergency Management	Wise County Public Schools	1 - Protection
4	New	Not Started	Flooding	Conduct an assessment to mitigate flooding at Stone Bridge (Proctor Street).	Public Works	Floodplain Coordinator	2 - Mitigation
5	New	Not Started	Flooding	Conduct an assessment of base flood elevation at mobile home park and relocation or elevation needs for residents.	Building & Zoning	Floodplain Coordinator	2 - Mitigation



**Big Stone Gap (Wise County) Actions 1-5**

Action #	Funding Source	Estimated Cost	Benefits	Priority	Timeline	Action Planning & Implementation	STAPLEE Score
1	VDEM, FEMA	Medium	Medium	Medium	Short-Term	Investigate the use of the FEMA Integrated Public Alert and Warning System (IPAWS) for Alerting Authorities; Deploy a public awareness campaign to encourage use of existing systems.	26
2	FEMA	Medium	Medium	High	Short-Term	Identify priority locations and water service vulnerabilities. Secure funding for storage tanks. Identify potential contractors for emergency water supply.	27
3	FEMA, local funds	High	Medium	High	Short-Term	Scope the costs for purchase and installment. Prioritize sites based on community and resident vulnerability, site size, and secured resources. Identify and secure funding.	28
4	FEMA, VDOT	Medium	Medium	Medium	Short-Term	Secure funding for an assessment. Prioritize needed mitigation actions identified. Scope project costs and design. Secure funding to complete projects.	24
5	FEMA	Medium	Medium	Medium	Short-Term	Identify project scope and cost. Develop communications and educational materials for residents. Secure funding and assistance.	22



**Big Stone Gap (Wise County) Actions 6-10**

Action #	New/Existing	Status	Hazard(s) Mitigated	Mitigation Action/Strategy	Lead Agency	Support Agencies	Goal
6	New	Not Started	Karst	Initiate a geotechnical study for karst terrain.	Building & Zoning	Virginia DMME	2 - Mitigation
7	New	Not Started	Landslide	Initiate a geotechnical impact assessment of the Big Stone Gap Water Treatment Plan from the 2019 Big Cherry Landslide.	Public Works	Wise County Public Service Authority	2 - Mitigation
8	New	Not Started	Landslide	Secure funding to install riprap to limit rockfall and further erosion along the Big Cherry Lake Dam.	Public Works	DCR	2 - Mitigation
9	New	Not Started	Non-Rotational Winds Tornado	Investigate the development and implementation of a tie-down ordinance for mobile homes.	Building & Zoning	Town Planning Department	2 - Mitigation 3 - Plans & Policies
10	New	Not Started	Winter Storm	Secure additional heavy equipment for snow removal operations and salt storage.	Public Works	Wise County and City of Norton Public Works	1 - Protection



Big Stone Gap (Wise County) Actions 6-10							
Action #	Funding Source	Estimated Cost	Benefits	Priority	Timeline	Action Planning & Implementation	STAPLEE Score
6	Virginia DNME, VDEM, EPA	Medium	Low	Low	Long-Term	Identify technical experts as project partners. Secure funding and assistance.	13
7	Virginia DCR, FEMA	Medium	High	High	Short-Term	Identify project scope and cost. Identify and recruit technical experts. Secure funding and assistance.	27
8	Virginia DCR, FEMA	Medium	Medium	Medium	Short-Term	Scope project extent and costs. Secure funding for project execution.	19
9	Local funds	Low	Medium	Medium	Short-Term	Review best practices in code and ordinances, as well as enforcement and compliance strategies. Prioritize and recommend changes.	17
10	FEMA, VDOT	High	Low	Low	Long-Term	Scope equipment needs and cost. Identify and secure funding.	14



Coeburn (Wise County) Actions 1-8							
Action #	New/ Existing	Status	Hazard(s) Mitigated	Mitigation Action/Strategy	Lead Agency	Support Agencies	Goal
1	New	Not Started	Drought	Address water quality concerns at Toms Creek Reservoir (Municipal Water Source).	Public Works	DWR	1 - Protection 3 - Plans & Policies
2	New	Not Started	Drought	Secure funding to make necessary upgrades to the water treatment facility and/or replacement of water lines between the facility and town.	Public Works	VDH	1 - Protection
3	New	Not Started	Flooding	Conduct a water study or survey to determine the need for future dredging of the Clinch River / Little Tom's Creek.	Public Works	DWR	2 - Mitigation 3 - Plans & Policies
4	New	Not Started	Flooding	Secure funding for an infiltration and inflow project to upgrade the wastewater system.	Public Works	VDH	1 - Protection 4 - Whole Community
5	New	Not Started	Dam Failure	Secure coal slurry above town at Tom's Creek Mine.	Virginia DMME	Public Works	1 - Protection 2 - Mitigation
6	New	Not Started	Dam Failure	Commission an engineering study of deteriorating banks of the Tom's Creek Reservoir.	Public Works	DWR, USACE	2 - Mitigation
7	New	Not Started	Karst	Identify and replace deteriorating water and drainage lines that can lead to sinkholes.	Public Works	VDH	2 - Mitigation
8	New	Not Started	Non-Rotational Wind Tornado Winter Storm	Conduct a survey to estimate the costs of burying utility lines.	Public Works	VDOT	1 - Protection





**Pound (Wise County) Actions 1-5**

Action #	New/Existing	Status	Hazard(s) Mitigated	Mitigation Action/Strategy	Lead Agency	Support Agencies	Goal
1	New	Not Started	All-Hazard	Develop an MOU to use the Job Corps facility as an emergency shelter or respite housing during disaster events, including public health emergencies.	Wise County Emergency Management	US Dept of Labor	1 - Protection 3 - Plans & Policies 4 - Whole Community
2	New	In Progress	Earthquake Flooding Non-Rotational Wind Tornado Winter Storm	Secure funding to demolish condemned structures in hazard-prone areas. Priority will be given to qualifying RL/SRL structures.	Public Works	Building, Zoning, and Code Enforcement	2 - Mitigation
3	New	In Progress	Earthquake Flooding Non-Rotational Winds Tornado Winter Storm	Purchase generators for emergency shelters at JW Adams Elementary School (Town of Pound), Union Elementary (Big Stone Gap), Wise Elementary School, and other locations as identified. Ensure all shelters are wired for portable generators.	Wise County Emergency Management	Wise County Public Schools	1 - Protection 4 - Whole Community
4	New	Not Started	Flooding	Conduct a water study to document the need for improved storm drain infrastructure.	Public Works	Floodplain Coordinator	2 - Mitigation
5	New	Not Started	Flooding	Secure funding for debris removal (trees, etc.) in the North Fork of the Pound River.	Public Works	DWR	2 - Mitigation



**Pound (Wise County) Actions 1-5**

Action #	Funding Source	Estimated Cost	Benefits	Priority	Timeline	Action Planning & Implementation	STAPLEE Score
1	Local funds, DHHS, VDOH	Low	Medium	Medium	Short-Term	Identify service population needs and managing organization capacity (CBO, faith-based org, city-operated, etc.) Scope project design and cost. Secure funding for construction and operations.	23
2	FEMA, VDEM	High	High	Medium	Ongoing	Provide information to owners of identified properties on acquisition/buy-out program options. Secure funding for property acquisition/demolition/relocation efforts. Secure funding for improvements for individual properties.	21
3	FEMA, local funds	High	Medium	High	Short-Term	Scope the costs for purchase and installment. Prioritize sites based on community and resident vulnerability, site size, and secured resources. Identify and secure funding.	29
4	FEMA	Medium	Medium	Medium	Short-Term	Scope project extent and costs. Identify potential contractors. Secure funding for project execution.	23
5	FEMA	Medium	Medium	Medium	Short-Term	Scope project extent and costs. Identify potential contractors. Secure funding for project execution.	23



Pound (Wise County) Actions 6-10							
Action #	New/Existing	Status	Hazard(s) Mitigated	Mitigation Action/Strategy	Lead Agency	Support Agencies	Goal
6	New	Not Started	Flooding	Identify and partner with an environmental protection organization to begin removal of invasive species along riverbanks.	Public Works	DWR	2 - Mitigation
7	New	In Progress	Karst	Secure funding to repair the sinkhole on Knowledge Drive in partnership with Wise County.	Public Works	VDOT	2 - Mitigation
8	New	In Progress	Landslide	Secure funding to repair damage from the landslide behind the bank building and mitigate further damage and sliding.	Public Works	VDEM	2 - Mitigation
9	New	Not Started	Landslide	Identify and mitigate potential landslide areas on critical roadways in/out of Pound.	VDOT	Public Works	2 - Mitigation 3 - Plans & Policies
10	New	Not Started	Wildfire	Secure funding for additional protective equipment, including turn-out gear for volunteer firefighters.	Pound Fire Department	Emergency Management	1 - Protection



Pound (Wise County) Actions 6-10							
Action #	Funding Source	Estimated Cost	Benefits	Priority	Timeline	Action Planning & Implementation	STAPLEE Score
6	Local funds	Low	Low	Medium	Short-Term	Scope project extent and costs. Identify potential partner organizations. Secure funding for project execution.	21
7	VDOT	High	High	High	Short-Term	Scope project extent and costs. Identify potential contractors. Secure funding for project execution.	27
8	VDEM, FEMA	High	High	High	Short-Term	Secure grant funding for the project.	27
9	VDOT, USDOT, FHWA, USFS, VA DOF	High	Medium	Medium	Ongoing	Review historic data on landslide events affecting roadways in partnership with VDOT. Determine priority mitigation actions. Determine authority responsible for improvements. Secure funding for projects as needed.	22
10	U.S. Fire Administration, USFS, VA Department of Forestry	Medium	Medium	Medium	Short-Term	Complete an assessment of equipment costs. Secure funding for purchase.	19



St. Paul (Wise County) Actions 1-4

Actions #	New/Existing	Status	Hazard(s) Mitigated	Mitigation Action/Strategy	Lead Agency	Support Agencies	Goal
1	New	Not Started	All-Hazard	Initiate the licensing of the Town of St. Paul Fire Department as an EMS agency to reduce the reliance on neighboring jurisdictions.	St. Paul Fire Department	VDH	1 - Protection 3 - Plans & Policies 4 - Whole Community
2	New	In Progress	All-Hazard	Incorporate emergency shelter designation and back-up generator capacity into the design of the new St. Paul Fire Department.	Fire Department	Emergency Management	1 - Protection 3 - Plans & Policies 4 - Whole Community
3	New	Not Started	Drought Dam Failure	Ensure adequate back-up potable water supplies to supplement municipal water sources and protect from potential coal slurry contamination through 1) the scope, cost estimate, and installation of a new water intake on the Clinch River, and 2) purchasing water-hauling trucks.	Public Works	Emergency Management	1 - Protection 4 - Whole Community
4	New	Not Started	Earthquake	Establish a contract for immediate replacement and/or repair of alternate parts for water and sewer systems in case of significant damage.	Public Works	Emergency Management	2 - Mitigation 3 - Plans & Policies



St. Paul (Wise County) Actions 1-4

Actions #	Funding Source	Estimated Cost	Benefits	Priority	Timeline	Action Planning & Implementation	STAPLEE Score
1	Local funds	Medium	High	High	Short-Term	Research regulations and licensing requirements. Secure funding for improvements, training, and application process as needed.	27
2	Local funds	High	High	High	Short-Term	Research emergency shelter design requirements and applicable federal/state regulations. Incorporate findings into ongoing design phase. Seek funding for mitigation elements as needed. Apply for official shelter designation.	28
3	FEMA; Virginia DMME; Virginia DCR	Medium	Medium	Medium	Short-Term	Identify priority locations and water service vulnerabilities. Secure funding for storage tanks. Identify potential contractors for emergency water supply.	20
4	Local funds	Low	Medium	Low	Short-Term	Identify potential contractors for alternate parts. Develop and establish contract. Seek funding as needed.	14





**St. Paul (Wise County) Actions 5-8**

<b>Actions #</b>	<b>New/Existing</b>	<b>Status</b>	<b>Hazard(s) Mitigated</b>	<b>Mitigation Action/Strategy</b>	<b>Lead Agency</b>	<b>Support Agencies</b>	<b>Goal</b>
5	New	Not Started	Earthquake Landslide	Determine structural and non-structural mitigation needs for ongoing and future damage to Third Avenue Bridge and nearby water line in partnership with VDOT.	Public Works	VDOT	2 - Mitigation
6	New	Not Started	Flooding	Replace two aging flood gates (currently protecting Morgan McClure Ford and an apartment building) which no longer seal properly.	Public Works	Floodplain Coordinator	2 - Mitigation
7	New	Not Started	Flooding	Replace the raw water intake on the Clinch River which is currently inaccessible and at-risk to service disruption during flooding events.	Public Works	VDH, DWR	2 - Mitigation 4 - Whole Community
8	New	Not Started	Winter Storm	Ensure all outlying pump stations are equipped/wired for a portable generator; purchase a portable generator to ensure continued water service.	Public Works	VDH	1 - Protection 4 - Whole Community



**St. Paul (Wise County) Actions 5-8**

<b>Actions #</b>	<b>Funding Source</b>	<b>Estimated Cost</b>	<b>Benefits</b>	<b>Priority</b>	<b>Timeline</b>	<b>Action Planning &amp; Implementation</b>	<b>STAPLEE Score</b>
5	VDOT, USDOT, FHWA	High	High	High	Ongoing	Review historic data on landslide events affecting the bridge in partnership with VDOT. Determine priority mitigation actions. Determine authority responsible for improvements. Secure funding for projects as needed.	29
6	FEMA	Medium	Medium	Medium	Short-Term	Scope the project cost and design. Identify and secure funding.	25
7	FEMA	High	Medium	Medium	Short-Term	Scope the project cost and design. Identify and secure funding.	22
8	FEMA	High	Medium	Medium	Short-Term	Scope the project cost and design. Identify priority sites for initial improvements. Identify and secure funding as needed.	21



Wise (Wise County) Actions 1-7							
Action #	New/ Existing	Status	Hazard(s) Mitigated	Mitigation Action/Strategy	Lead Agency	Support Agencies	Goal
1	New	Not Started	Communicable Disease	Establish a mutual support agreement for contracted services (increased sanitation, etc.) during a declared pandemic.	Wise County Health Department	VDH	1 - Protection
2	New	Not Started	Dam Failure	Install an outdoor warning system for residents within the Bear Creek Dam / Wise Reservoir inundation area.	Emergency Management	DCR, USACE	1 - Protection
3	New	Not Started	Dam Failure Drought	Conduct a project scope to purchase and install a new pump and control equipment for the back-up well to the Wise Municipal Water Source.	Wise County Public Service Authority	VDH, DWR	2 - Mitigation
4	New	Not Started	Flooding	Initiate improvements and repairs to culvert, road damages, and storm drainage infrastructure at Yellow Creek/Railroad Avenue and School Avenue.	Public Works	VDOT, VDEM, Army Corps, BCR	2 - Mitigation
5	New	Not Started	Landslide	Repair the high wall on Lake Street and enhance structural protections to prevent damages to the roadway from future landslides.	Public Works	VDOT	3 - Policies & Plans
6	New	Not Started	Wildfire	Secure a new apparatus for the local fire department that can respond to wildfire/grassfire events, as well as additional protective equipment.	Wise Fire Department	Town Administrator/ Clerk	1 - Protection
7	New	Not Started	Winter Storm	Construct a salt storage facility to improve critical roadway access and reduce supply issues.	Public Works	VDOT	1 - Protection



Wise (Wise County) Actions 1-7							
Action #	Funding Source	Estimated Cost	Benefits	Priority	Timeline	Action Planning & Implementation	STAPLEE Score
1	Local funds	Low	Low	Medium	Short-Term	Wise County and the Town of Wise will establish a mutual support agreement and grant funding to support contracted services such as increased sanitation and cleaning of buildings and other facilities. This will require identifying potential contractors, securing funding, and identifying priority needs for services based on lessons learned from the COVID-19 pandemic.	19
2	Virginia DCR, FEMA	Medium	High	Medium	Short-Term	Develop a project scope based on the inundation area that includes the number and type of signals/structures. Secure funding. Install warning system. Conduct an outreach and awareness campaign to notify residents of the new system.	23
3	FEMA	Low	Medium	Medium	Short-Term	Seek funding and assistance.	22
4	FEMA, VDOT	High	High	Medium	Short-Term	Conduct a project scope, cost and design assessment. Seek funding and assistance.	23
5	VDOT, USDOT, FHWA, USFS, VA DOF	High	High	Medium	Short-Term	Review historic data on landslide events affecting the roadway in partnership with VDOT. Determine possible mitigation actions. Determine authority responsible for improvements. Secure funding for projects as needed.	24
6	U.S. Fire Administration, USFS, VA Department of Forestry	High	Medium	Medium	Short-Term	Complete an assessment of equipment costs. Secure funding for purchase.	26
7	VDOT, USDOT, FHWA	High	Medium	Low	Long-Term	Assess capacity and design needs. Scope alternatives and costs. Secure funding for purchase.	14



Ongoing, Completed, or Removed Actions

Many mitigation actions identified in 2013 were unable to be completed due to the lack of funding and staffing. In the years coming, jurisdictions in the District have made mitigation planning and action a top priority. The first step to completing many of the projects remaining from the 2013 plan will be identifying funding sources. Other actions have been completed since the 2013 plan, adapted in new actions, or removed due to discontinued participation.

**District-Wide On-Going Actions 1-7**

Action #	Hazard(s) Mitigated	Mitigation Action/Strategy	Lead Agency	Support Agencies	Goal
1	Flooding	Target FEMA's Repetitive Loss Properties, and other known repetitively flooded properties, throughout the district for potential mitigation projects.	Local Floodplain Coordinators	Local Emergency Operations Coordinators; Community Planners	1 - Protection 2 - Mitigation 3 - Polices & Plans
2	Flooding	Support Public Works initiatives to improve stormwater infrastructure throughout the area.	Local Floodplain Coordinators	Local Emergency Operations Coordinators; Community Planners	2 - Mitigation
3	All-Hazards	Perform analysis of emergency communication systems in all jurisdictions to ensure compatibility during an event.	Local Emergency Operations Coordinators	911 PSAPs in the District	1 - Protection 4 - Whole Community
4	All-Hazards	Initiate and encourage dialogue with public utility companies about incorporating mitigation as infrastructure is laid, maintained, or repaired.	Planning District	Public Utilities	1 - Protection 2 - Mitigation
5	All-Hazards	Develop "hazard information centers" on local communities' websites, in public libraries and via social media, where individuals can find hazard and mitigation information.	Planning District	Local Emergency Operations Coordinators; Community Planners; Website and Social Media Coordinators	1 - Protection 4 - Whole Community
6	Wildfire	Utilize existing wildfire maps to prioritize potential project areas in the district.	LENOWISCO Planning District Commission	Local Fire Departments, U.S. Forest Service; Virginia Department of Forestry	2 - Mitigation



District-Wide On-Going Actions 1-7

Action #	Funding Source	Estimated Cost	Benefits	Priority	Timeline	Action Planning & Implementation
1	HMA Programs, Local funds	High	High	Low	Ongoing	Work with the State, PDC, and localities to identify vulnerable structures and apply for funding to implement acquisition, elevation, and demolition projects. RL and SRL properties are targeted for this project type. Acquisition and demolition projects completely remove the structure from the floodplain, reducing any future damages. The District will also support the jurisdictions in keeping an accurate account and database of projects.
2	HMA Programs, Local funds, Public Utility Funding	High	High	Medium	Ongoing	Many of the jurisdictions have made improvements to their stormwater infrastructure since the 2013 plan. As additional funding is available, the District will support jurisdictions in further improving their stormwater infrastructure.
3	FEMA, VDEM, Local funds	Medium	High	High	Ongoing	Identify continuing funding for the CodeRed warning system; Investigate the use of the FEMA Integrated Public Alert and Warning System (IPAWS) for Alerting Authorities; Deploy a public awareness campaign to encourage use of existing systems.
4	Local Funds	Low	High	Medium	Ongoing	While the utility companies are ultimately responsible for the installation costs, the District will continue to be proactive with including the utility companies in mitigation discussions and educational sessions. Further, cost-share mitigation efforts are included under jurisdiction mitigation plans in this update.
5	Local Funds	Low	High	Medium	Ongoing	The District continues to recognize the need to provide more information on hazard mitigation to the public. Since 2013, many jurisdictions and the County have created a social media presence to share information with the residents. Not all residents have computers or smart phones so the District is looking at initiatives to supply the hazard mitigation information in public spaces frequented by the public.
6	Virginia Department of Forestry	Low	High	High	Long-Term	As funding is identified for wildfire mitigation projects, the District will continue to utilize the Wildfire Maps and Wildland Urban Interface maps created by the Department of Forestry to identify areas of primary concern. The District will support maps updates to ensure the maps remain current.





**Completed Actions 1-5**

<b>Action #</b>	<b>Status</b>	<b>Mitigation Action/Strategy</b>	<b>Applicable Jurisdiction</b>	<b>Action Planning &amp; Implementation</b>
1	Completed	Undertake educational outreach activities by developing and distributing brochures and education materials for FEMA's Repetitive Loss Properties, with specific mitigation measures emphasizing acquisition, relocation, and elevation.	District-wide	Since the 2013, the District supported jurisdictions in educating the public on acquisition projects and acquisition projects have occurred as funding is allocated. The public is aware of the need for acquisition, relocation, and elevation projects.
2	Completed	Stormwater mitigation, upgrades to main interceptor in central business district	Norton	The City of Norton completed a number of stormwater mitigation projects since the 2013 plan. The City of Norton developed a new targeted mitigation action to continue enhancing the community's flooding resilience.
3	Completed	Stormwater mitigation, drainage culverts underneath downtown	Pennington Gap	Since the 2013 plan, stormwater mitigation projects were implemented. The primary concern for flooding is now the potential tunnel failure and a new mitigation action was identified.
4	Completed	Potential residential acquisition project(s) in flood-prone areas	Scott County	Since the 2013 plan, several acquisition projects occurred in Scott County. Exact dates of acquisition were not recorded and a past mitigation action under the District was updated to include better tracking of acquisition projects. Scott County recognizes that flooding remains a hazard likely to impact the area and developed a new mitigation action focused on improved stormwater drainage.
5	Completed	Potential residential acquisition project(s) in flood-prone areas	Town of Wise	Since the 2013 plan, several acquisition projects occurred. Exact dates of acquisition were not recorded and a past mitigation action under the District was updated to include better tracking of acquisition projects. The town identifies the need for better drainage and improved culverts as the primary mitigation actions necessary to continue to enhance the town's resilience from flooding.



Removed Mitigation Actions 1-5

Action #	Status	Mitigation Action/Strategy	Applicable Jurisdiction	Action Planning & Implementation
1	Removed	Investigate critical facilities to evaluate resistance to wind, fire, landslide and flood hazards. Examine critical facilities within the district's communities and make recommendations to address deficiencies.	District-wide	The District recognized the need to reframe the action to specific hazards and specific critical facilities and the importance of jurisdictions serving as the lead agency for critical facilities within their jurisdiction. The action is reframed under jurisdictions.
2	Removed	Evaluate the district's community floodplain ordinances and enforcement procedures that may be outdated for possible upgrades.	District-wide	The District continues to support floodplain management; however, the revisions of ordinances is best done and supported at the County-level.
3	Removed	Potential residential acquisition project(s) in flood-prone areas	Jonesville	Jonesville did not participate in the 2021 update. The acquisition project continues as a District-wide initiative.
4	Removed	Need for early warning system in town	Jonesville	Jonesville did not participate in the 2021 update
5	Removed	Need improvements in early warning system in town.	Pennington Gap	



### 1 1.7.3 Plan Integration Strategy

2 Plan integration is the process by which communities look critically at their existing planning  
3 framework and align efforts with the goal of building a safer, smarter community. Plan  
4 integration involves a two-way exchange of information and incorporation of ideas and concepts  
5 between the LENOWISCO Planning District Hazard Mitigation Plan and other community plans.  
6 Specifically, plan integration involves the incorporation of hazard mitigation principles and  
7 actions into community plans and community planning mechanisms.

8 The 2013 mitigation actions were not incorporated into other county or city plans due to limited  
9 staff capacity. However, the ongoing revisions to comprehensive plans for some counties and  
10 local jurisdictions provide the perfect opportunity for the mitigation plan and actions to be  
11 incorporated into these plans.

12 The LENOWISCO Planning District and its participating jurisdictions are committed to  
13 the integration of mitigation into other community plans and efforts. Several new or updated  
14 planning efforts, as well as ordinance updates are included as new mitigation  
15 actions. Additionally, the draft HMP was shared with local jurisdiction staff for review and  
16 incorporation in upcoming plans and ordinances. Ongoing plan integration efforts include:

- 17 • All mitigation actions should be reviewed and incorporated when their county or city  
18 comprehensive plans and Comprehensive Emergency Management Plan (CEMP) are  
19 updated.
- 20 • County and cities should consider mitigation actions, especially high priority projects, in  
21 budget plans.
- 22 • Local floodplain managers should integrate the mitigation actions with floodplain and  
23 NFIP planning.
- 24 • Building and zoning officials should investigate updated or new zoning  
25 ordinances outlined in the mitigation actions.
- 26 • County and town administrators should integrate mitigation actions with  
27 ongoing continuity of operations planning.
- 28 • Local fire departments and Forest Service officials will integrate the Plan and action  
29 items with future Community Wildfire Protection Plan and Wildland-Urban Interface  
30 Plans.
- 31 • Local economic development committees and the regional Economic Development  
32 District will should integrate the Plan and action items with the upcoming Comprehensive  
33 Economic Development Strategy (CEDS) plan update in 2021-2022.

34



### 1.7.4 NFIP Mitigation Actions

The following mitigation strategies and actions demonstrate LENOWISCO and its participating jurisdictions' continued support and compliance with NFIP requirements, as appropriate. Only those actions that demonstrate specific support and compliance with the program are included. Other flood-related projects were not included in this section.

**Table: NFIP-Specific Mitigation Actions**

Jurisdiction	Status	Year Initiated	Hazard(s) Mitigated	Mitigation Action	Lead Agency/Organization	Supporting Agency	Priority
District-Wide	Existing	2013	Flooding	Ensure continued compliance in the National Flood Insurance Program (NFIP) through enforcement of local floodplain management ordinances and take steps to participate in the Community Rating System (CRS).	Local Floodplain Coordinators	Local Emergency Operations Coordinators	High
Scott County	New	2021	Flooding	Conduct a water study to document the need for improved storm drain infrastructure.	Public Works	Floodplain Coordinator	Medium
Gate City	New	2021	Earthquake Flooding Non-Rotational Winds Tornado Winter Storm	Create a strategy to inspect and document vacant buildings that may pose a threat to public safety during a hazard event.	Building & Zoning	Public Works	High



Big Stone Gap	New	2021	Flooding	Conduct an assessment of base flood elevation at mobile home park and relocation or elevation needs for residents.	Building & Zoning	Floodplain Coordinator	Medium
Pound	New	2021	Earthquake Flooding Non-Rotational Wind Tornado Winter Storm	Secure funding to demolish condemned structures in hazard-prone areas. Priority will be given to qualifying RL/SRL structures.	Public Works	Building, Zoning, and Code Enforcement	Medium

DRAFT



## 1 **Section 1.8 Plan Maintenance and Implementation**

2 The Disaster Mitigation Act of 2000 requires the monitoring, evaluation, and updating of the  
3 hazard mitigation plan every five years. This hazard mitigation plan is designed to be a “living”  
4 document and therefore will be reviewed and updated within five years from its approval date.  
5 The LENOWISCO Planning District hazard mitigation planning team will provide leadership and  
6 guidance throughout the plan’s life cycle (i.e., monitoring, evaluating and updating.) Updates will  
7 allow municipal leaders and the public to provide input into the process. The public will be  
8 notified of this opportunity via legal public notices.

9 The LENOWISCO Planning District multi-hazard mitigation plan maintenance process includes  
10 a schedule for annual monitoring and evaluation of the programmatic outcomes established in  
11 the Plan and for producing a formal Plan revision every five years.

12

DRAFT





1 **1.8.1 Formal Review Process**

2 Since the development of the 2013 Hazard Mitigation Plan, LENOWISCO Planning  
3 District continued to monitor, evaluate, and update the Plan. The monitoring, evaluating, and  
4 updating process will continue throughout the next 5 years.

5 The Plan will be reviewed on an annual basis by the core planning team and reviewed and  
6 revised every five years to determine the effectiveness of programs and to reflect changes that  
7 may affect mitigation priorities. The LENOWISCO Planning District will be responsible for  
8 contacting the planning team members and organizing the review. Members will be responsible  
9 for monitoring and evaluating the progress of the mitigation strategies in the Plan. The planning  
10 team will review the goals and action items to determine their relevance to changing situations  
11 in the District, as well as changes in Federal policy, and to ensure they are addressing current  
12 and expected conditions. The planning team will also review the risk assessment portion of the  
13 Plan to determine if this information should be updated or modified, given any new available  
14 data. The organizations responsible for the various action items will report on the status of the  
15 projects, the success of various implementation processes, difficulties encountered, the success  
16 of coordination efforts, and which strategies should be revised or removed.

17 LENOWISCO Planning District will be responsible for ensuring the updating of the  
18 Plan. LENOWISCO Planning District and the planning team will also notify all holders of the Plan  
19 and affected stakeholders when changes have been made. The updated Plan will be submitted  
20 to the Commonwealth of Virginia and to the Federal Emergency Management Agency for review  
21 and approval.

22

DRAFT



## 1 1.8.2 Monitoring, Evaluating, and Updating the Plan

2 To ensure the Plan continues to provide an appropriate path for risk reduction throughout  
3 the District, it is necessary to regularly evaluate and update it. The planning team will be  
4 responsible for monitoring the status of the Plan and gathering appropriate parties to report of  
5 the status of mitigation actions. The planning team will convene on an annual basis to determine  
6 the progress of the identified mitigation actions. The planning team will also be an active  
7 participant in the next plan update. As the Multi-Hazard Mitigation Plan matures, new  
8 stakeholders will be identified and encouraged to join the existing planning team.

9 LENOWISCO Planning District is responsible for contacting planning team members and  
10 organizing the annual meeting. The planning team's responsibilities include:

- 11 • Members of the planning team will be readily available to engage via meetings or e-mail  
12 correspondence between annual meetings. If the need for a special meeting (due to new  
13 developments or a declared disaster) occurs in the District, the planning team will meet  
14 to update mitigation strategies. Depending on grant opportunities and fiscal resources,  
15 mitigation projects may be implemented independently by individual communities or  
16 through local partnerships.
- 17 • Reassess the Plan considering any major hazard event. The committee will convene  
18 within 90 days of any major event to review all applicable data and to consider the risk  
19 assessment, plan goals, objectives, and action items given the impact of the hazard  
20 event.
- 21 • Annually reviewing each goal and objective to determine its relevance and  
22 appropriateness.
- 23 • Monitor and evaluate the mitigation strategies in this Plan to ensure the document  
24 reflects current hazard analyses, development trends, code changes and risk analyses  
25 and perceptions.
- 26 • Ensure the appropriate implementation of annual status reports and regular  
27 maintenance of the Plan. The planning team will hear progress reports from the parties  
28 responsible for the various implementation actions to monitor progress.
- 29 • Create future action plans and mitigation strategies. These should be carefully assessed  
30 and prioritized using benefit-cost analysis (BCA) methodology that FEMA has  
31 developed.
- 32 • Ensure the public is invited to comment and be involved in mitigation plan updates.
- 33 • Ensure that the District complies with all applicable Federal statutes and regulations  
34 during the periods for which it receives grant funding, in compliance with 44 CFR.
- 35 • Review the multi-hazard mitigation plan in connection to other plans, projects,  
36 developments, and other significant initiatives.
- 37 • Significant updates or modifications to the Plan during the five-year planning process will  
38 require a public notice and a meeting prior to submitting revisions to the individual  
39 jurisdictions for approval.
- 40 • Coordinate with appropriate municipalities and authorities to incorporate regional  
41 initiatives that transcend the boundaries of the District.
- 42 • Update the plan every five years and submit for FEMA approval.
- 43 • Amend the plan whenever necessary to reflect changes in State or Federal laws and  
44 statutes required in 44 CFR.



### 1 **1.8.3 The Five-Year Action Plan**

2 This section outlines the implementation agenda that the planning team should follow five years  
3 following adoption of this Plan, and then every five years thereafter. The planning team, led  
4 by LENOWISCO Planning District, is responsible to ensure the Multi-Hazard Mitigation Plan is  
5 updated every five years.

6 The planning team will consider the following an action plan for the first 5-year planning cycle. It  
7 should be noted that the schedule below can be modified as necessary and does not include  
8 any meetings and/or activities that would be necessary following a disaster event (which would  
9 include reconvening the planning team within 90 days of a disaster or emergency to determine  
10 what mitigation projects should be prioritized during the community recovery). If an  
11 emergency meeting of the planning team occurs, this proposed schedule may be altered to fit  
12 any new needs.

#### 13 **Year 0:**

- 14 • **January – March 2021:** Update Multi-Hazard Mitigation Plan, including a series  
15 of planning team meetings & public meetings. Submit 2021 Multi-Hazard Mitigation Plan  
16 for State and FEMA approval.
- 17 • **April – December 2021:** Work on mitigation actions. The core planning team will stay in  
18 contact with lead departments/municipalities to keep tabs on mitigation project status  
19 and progress.
- 20 • Participating jurisdictions will formally adopt the 2021 Multi-Hazard Mitigation Plan upon  
21 State and FEMA approval.

#### 22 **Year 1:**

- 23 • **January – March 2022:** Prepare for and promote first annual plan review and  
24 public meetings. District and participating jurisdictions will provide a status update for  
25 each mitigation action/project.
- 26 • **April 2022:** Reconvene planning team for first annual mitigation meeting. Introduce the  
27 concept of mitigation plan integration with other planning documents. Host first annual  
28 public meeting.
- 29 • **May – December 2022:** Work on mitigation actions. The core planning team will stay in  
30 contact with lead departments/municipalities to keep tabs on mitigation project status  
31 and progress. Encourage plan integration efforts.

#### 32 **Year 2:**

- 33 • **January – March 2023:** Prepare for and promote second annual plan review and  
34 public meetings. District and participating jurisdictions will provide a status update for  
35 each mitigation action/project.
- 36 • **April 2023:** Reconvene planning team for second annual mitigation meeting. Review  
37 plan integration efforts. Host second annual public meeting.
- 38 • **May – December 2023:** Work on mitigation actions. The core planning team will stay in  
39 contact with lead departments/municipalities to keep tabs on mitigation project status  
40 and progress. Encourage plan integration efforts.

41



1 **Year 3:**

- 2
- 3 • **January – March 2024:** Prepare for and promote third annual plan review and  
4 public meetings. District and participating jurisdictions will provide a status update for  
5 each mitigation action/project.
  - 6 • **April 2024:** Reconvene planning team for third annual mitigation meeting. Review plan  
7 integration efforts. Host third annual public meeting.
  - 8 • **May – December 2024:** Work on mitigation actions. The core planning team will stay in  
9 contact with lead departments/municipalities to keep tabs on mitigation project status  
10 and progress. Encourage plan integration efforts.
  - 11 • LENOWISCO Planning District will ask planning team members to volunteer to begin the  
12 process of bringing in a contractor to make plan updates for 2026 completion.

12 **Year 4:**

- 13
- 14 • **January – March 2025:** Prepare for and promote four annual plan review and  
15 public meetings. District and participating jurisdictions will provide a status update for  
16 each mitigation action/project.
  - 17 • **April 2025:** Reconvene planning team for fourth annual mitigation meeting. Review plan  
18 integration efforts. Host fourth annual public meeting.
  - 19 • **May – December 2025:** Work on mitigation actions. The core planning team will stay in  
20 contact with lead departments/municipalities to keep tabs on mitigation project status  
21 and progress. Encourage plan integration efforts.

21 **Year 5:**

- 22
- 23 • **January – December 2026:** Update 2021 Multi-Hazard Mitigation Plan, including a  
24 series of mitigation planning team meetings and public meetings.
  - 25 • Submit 2026 Multi-Hazard Mitigation Plan for State and FEMA approval. Repeat.



## 1.8.4 Annual Mitigation Steering Committee Meeting

During each annual mitigation meeting, the planning team will be responsible for a brief evaluation of the 2021 Multi-Hazard Mitigation Plan and to review the progress on mitigation actions.

### Plan Evaluation

To evaluate the plan, the mitigation planning team should answer the following questions:

- Are the goals and objectives still relevant?
- Is the risk assessment still appropriate, or has the nature of the hazard and/or vulnerability changed over time?
- Are current resources appropriate for implementing this Plan?
- Have lead agencies participated as originally proposed?
- Has the public been adequately involved in the process? Are their comments being heard?
- Have departments been integrating mitigation into their planning documents?

If the answer to each of the above questions is “yes,” the plan evaluation is complete. If any questions are answered with a “no,” the identified gap must be addressed.

### Review of Mitigation Actions

Once the plan evaluation is complete, the planning team must review the status of the mitigation actions. To do so, the mitigation planning team should answer the following questions:

- Have the Mitigation Actions been implemented as planned?
- Have outcomes been adequate?
- What problems have occurred in the implementation process?

Each mitigation action/strategy includes the following table to track annual updates and progress for each mitigation action. Lead agencies/organizations will be tasked to provide an annual status update for each action.

Year	Status	Comments
2019	New, Ongoing, Revised, Complete	
2020		
2021		
2022		
2023		

26

### Meeting Documentation

Each annual mitigation meeting must be documented, including the plan evaluation and review of Mitigation Actions. Mitigation Actions have been formatted to facilitate the annual review process.

30



## 1 1.8.5 Continued Public Involvement

2 LENOWISCO Planning District is dedicated to involving the public directly in the review and  
3 updates of the Plan. The planning team is responsible for the review and update of the  
4 Plan. The public will also provide input into Plan revisions and updates. Copies of the Plan will  
5 be kept by appropriate District and municipalities.

6 Public meetings will be held when deemed necessary by the planning team. The meetings will  
7 provide a forum where the public can express concerns, opinions, or new alternatives that can  
8 then be included in the Plan. LENOWISCO Planning District will be responsible for  
9 using District resources to publicize the public meetings and maintain public involvement.

10 To further facilitate continued public involvement in the planning process, the LENOWISCO  
11 Planning District will ensure that:

- 12 • Once adopted, a digital copy of this plan will be maintained in each jurisdiction and in  
13 the LENOWISCO Planning District. The District will keep a hard copy and digital copy of  
14 the Plan at the LENOWISCO Planning District building for review and comment by the  
15 public.
- 16 • The District will conduct outreach after a disaster incident to remind members of the  
17 importance of mitigation and to solicit mitigation ideas to be included in the Plan.
- 18 • Education efforts for hazard mitigation will be ongoing through the county emergency  
19 management offices. The public will be notified of periodic planning meetings through  
20 notices in the local newspaper or press releases. The regional public  
21 education campaign will include mitigation actions for residents to undertake, such as  
22 raising appliances in the lower level of homes and buying proper insurance.
- 23 • Public meetings will be held immediately following planning team meetings annually to  
24 give the public an opportunity to receive information on plan updates and offer input on  
25 plan improvements.
- 26 • As the Plan is updated annually, a summary of the changes will be added to the  
27 LENOWISCO Planning District's public-facing website with an updated version of the  
28 plan (to include 2022 action updates, etc.) for the public to monitor progress on specific  
29 actions and remain engaged.
- 30 • Comments from the public on the Plan will be received by LENOWISCO Planning  
31 District and forwarded to the committee for discussion, as appropriate and as needed.

32





1 **1.8.6 Implementation and Integration through Existing Plans and**  
2 **Programs**

3 Hazard mitigation practices must be incorporated within existing plans, projects, and programs.  
4 Therefore, the involvement of all departments, private non-profits, private industry, and  
5 appropriate jurisdictions is necessary to find mitigation opportunities within existing or planned  
6 projects and programs. To execute this, the planning team will assist and coordinate resources  
7 for the mitigation actions and provide strategic outreach to implement mitigation actions that  
8 meet the goals and objectives identified in this plan.

9 The results of this Plan will be incorporated into ongoing planning efforts throughout  
10 the District. LENOWISCO Planning District and its incorporated jurisdictions will update zoning  
11 plans and related ordinances, as necessary, and as part of regularly scheduled updates. Each  
12 community will be responsible for updating and integrating elements of the Plan into the  
13 community's own respective community plans and ordinances.

14

15

DRAFT



1 **Appendix A: Public Involvement & Steering Committee**  
2 **Meetings**

3 Public involvement was a critical component of the Hazard Mitigation Plan and Appendix A  
4 highlights the main involvements of the public, including the Community Preparedness Survey  
5 questions and summary of responses, public and planning team meetings, and public  
6 notification of plan review.

7

DRAFT



1 **A.1 Survey Questions**

2 LENOWISCO Community Preparedness Survey

---

3  
4 **Instructions**

5 To Whom It May Concern:

6  
7 LENOWISCO Planning District is conducting a study to better understand the preparedness  
8 needs and risk perceptions of its residents as part of the Hazard Mitigation Plan update process.  
9 To do so, a questionnaire has been distributed throughout Lee County, Scotty County, Wise  
10 County, and City of Norton. Your feedback is greatly needed and appreciated!

11  
12 The questionnaire should only take about 10 minutes to complete. All responses will be kept  
13 confidential, and your participation is strictly voluntary. Your input will enable the LENOWISCO  
14 Planning District to better serve you.

15  
16 **Survey Completion Date**

17 Please complete the survey by January 31, 2021.

18  
19 **CONTACT US**

20 If you have any questions, please contact:

21 Frank W. Kibler

22 Senior Planner, LENOWISCO Planning District Commission

23 [fkibler@lenowisco.org](mailto:fkibler@lenowisco.org)

24 (276) 431-2206

25 [www.lenowisco.org](http://www.lenowisco.org)

26  
27 **DEFINITIONS**

28 Hazard Mitigation: The purpose of hazard mitigation planning is to identify policies and actions  
29 that can be implemented over the long term to reduce risk and future losses. Mitigation forms  
30 the foundation for a community's long-term strategy to reduce disaster losses and break the  
31 cycle of disaster damage, reconstruction, and repeated damage.

32  
33 Thank you for your participation.

---

34  
35 **Residency**

36 1) Do you live and/or work in LENOWISCO Planning District? Please select the best answer  
37 that applies to your current situation.\*

38  
39  I work/live in Lee County

40  I work/live in Scott County

41  I work/live in Wise County

42  I work/live in City of Norton

43  Other - Write In

44  No, I do not live or work in the LENOWISCO Planning District

45

46

---



- 1 Residency and Employment Information  
2  
3 2) Approximately how many years have you lived in LENOWISCO Planning District?  
4 ( ) 0-2 years  
5 ( ) 3-5 years  
6 ( ) 6-10 years  
7 ( ) 11-20 years  
8 ( ) 21 or more years  
9 ( ) Not Applicable  
10 ( ) Do Not Know  
11 ( ) Other (please specify): \_\_\_\_\_  
12  
13 3) Approximately how many years have you worked in LENOWISCO Planning District?  
14 ( ) 0-2 years  
15 ( ) 3-5 years  
16 ( ) 6-10 years  
17 ( ) 11-20 years  
18 ( ) 21 or more years  
19 ( ) Not Applicable  
20 ( ) Do Not Know  
21 ( ) Other (please specify): \_\_\_\_\_  
22  
23 4) Please indicate which community in LENOWISCO Planning District you live in.  
24 [ ] City of Norton  
25 [ ] Town of Appalachia  
26 [ ] Town of Big Stone Gap  
27 [ ] Town of Clinchport  
28 [ ] Town of Coeburn  
29 [ ] Town of Duffield  
30 [ ] Town of Dungannon  
31 [ ] Town of Gate City  
32 [ ] Town of Jonesville  
33 [ ] Town of Nickelsville  
34 [ ] Town of Pennington Gap  
35 [ ] Town of Pound  
36 [ ] Town of St. Charles  
37 [ ] Town of St. Paul  
38 [ ] Town of Weber City  
39 [ ] Town of Wise  
40 [ ] Unincorporated Lee County  
41 [ ] Unincorporated Scott County  
42 [ ] Unincorporated Wise County  
43 [ ] Other - Write In  
44  
45 5) Please indicate which community in LENOWISCO Planning District you work in.  
46 [ ] City of Norton  
47 [ ] Town of Appalachia



- 1  Town of Big Stone Gap
- 2  Town of Clinchport
- 3  Town of Coeburn
- 4  Town of Duffield
- 5  Town of Dungannon
- 6  Town of Gate City
- 7  Town of Jonesville
- 8  Town of Nickelsville
- 9  Town of Pennington Gap
- 10  Town of Pound
- 11  Town of St. Charles
- 12  Town of St. Paul
- 13  Town of Weber City
- 14  Town of Wise
- 15  Unincorporated Lee County
- 16  Unincorporated Scott County
- 17  Unincorporated Wise County
- 18  Other - Write In

---

19  
20 General Preparedness

21  
22 6) Please indicate what type of device(s) you use to access the internet. Select ALL that apply.

- 23  Computer/laptop at home
- 24  Computer/laptop at work/office
- 25  iPad/tablet
- 26  Cell phone
- 27  Public computer (i.e. library)
- 28  I do not have access to the Internet
- 29  Do Not Know
- 30  Other (please specify): \_\_\_\_\_

31  
32 7) Please indicate those activities you have done to prepare for emergencies and disasters.  
33 Please select ALL that apply.

- 34  
35 I have...
- 36  Smart 911/Rave Alert
- 37  An emergency preparedness plan
- 38  Flood Insurance
- 39  A 72 hour kit/disaster supply kit
- 40  Visited local government web site(s) for emergency preparedness information
- 41  An evacuation plan
- 42  A weather radio
- 43  Signed up for emergency alerts for LENOWISCO Planning District (from any source)
- 44  Done nothing
- 45  Other (please specify): \_\_\_\_\_

46



- 1 8) Have any of the reasons below prevented you from pursuing additional preparedness  
2 activities? Please select ALL that apply.  
3  I don't think it will make a difference.  
4  I don't know what to do.  
5  I don't have the time.  
6  It costs too much.  
7  I don't need to prepare because emergency responders (fire, police, etc.) will help me during  
8 an emergency.  
9  None of the above apply to me.  
10  Other (please specify): \_\_\_\_\_  
11

- 12 9) Please indicate where you go to obtain emergency and disaster preparedness related  
13 information? Please select ALL that apply.  
14  Municipal government websites  
15  County government website  
16  Virginia Commonwealth government website  
17  Federal government websites (example: www.fema.gov)  
18  Web search (example: bing.com, google.com)  
19  Social media (example: Facebook, twitter, google , etc.)  
20  Voluntary organizations (example: American Red Cross, Salvation Army, etc.)  
21  Religious Organization  
22  Local English-speaking television  
23  Local English-speaking radio  
24  Local Spanish-speaking radio  
25  National News (Radio and Television)  
26  Print Media - English (example: newspapers)  
27  Brochures and Newsletters  
28  Word of Mouth (example: friends, family, co-workers)  
29  Other (please specify): \_\_\_\_\_  
30  Do Not Know  
31  Not Applicable  
32

- 33 10) Please indicate how you expect to receive alerts and information during an emergency.  
34 Please select ALL that apply.  
35  A weather radio  
36  Private Weather Phone Applications (ex. Weather Channel, Wunderground, Weather Bug,  
37 AccuWeather, etc.)  
38  Preparedness Phone Applications (ex. FEMA, Red Cross, etc.)  
39  Local Media Phone Applications  
40  LENOWISCO Emergency Management website  
41  Local Television Media  
42  Local Radio  
43  Social Media  
44  Word of Mouth  
45  Do Not Know  
46  Other (please specify): \_\_\_\_\_  
47





1 11) Would you agree or disagree with the following statements?

	Strongly Agree	Agree	Neither Agree nor Disagree	Disagree	Strongly Disagree	Do Not Know
My jurisdiction is providing the services necessary to prepare me for a disaster.	<input type="radio"/>	<input type="radio"/>	<input type="radio"/>	<input type="radio"/>	<input type="radio"/>	<input type="radio"/>
I am familiar with LENOWISCO Planning District's website and can easily obtain information about emergencies and disasters.	<input type="radio"/>	<input type="radio"/>	<input type="radio"/>	<input type="radio"/>	<input type="radio"/>	<input type="radio"/>
During times of emergency, information is provided in a language and format I can understand.	<input type="radio"/>	<input type="radio"/>	<input type="radio"/>	<input type="radio"/>	<input type="radio"/>	<input type="radio"/>
I can easily obtain emergency information in times of crisis.	<input type="radio"/>	<input type="radio"/>	<input type="radio"/>	<input type="radio"/>	<input type="radio"/>	<input type="radio"/>

2

3 12) Please indicate how LENOWISCO Planning District can better assist you in preparing for  
 4 emergencies and disasters (example: provide preparedness materials in my language).

5 \_\_\_\_\_  
 6 \_\_\_\_\_  
 7 \_\_\_\_\_  
 8 \_\_\_\_\_

9

10 13) If a disaster (i.e. snowstorm) impacted LENOWISCO Planning District, knocking out  
 11 electricity and running water, would your household be able to manage on its own for at least  
 12 three (3) days?

- 13  Yes
- 14  Maybe
- 15  No
- 16  Do Not Know

17

18 14) Which of the following may prevent you from recovering from a disaster? Please  
 19 select ALL that apply.

- 20  Lack of financial savings



- 1  Disruption in employment
- 2  No access to healthcare
- 3  Mental health concerns
- 4  Lack of insurance (i.e. home owners insurance, renter's insurance, flood insurance, etc.)
- 5  Lack of alternative housing options
- 6  Lack of outside support from family
- 7  Limited food supply
- 8  Limited water supply
- 9  No alternative power supply
- 10  Not Applicable
- 11  Do Not Know
- 12  Other (please specify): \_\_\_\_\_

13  
 14 \_\_\_\_\_

15 Hazards  
 16 15) Do you believe that your household and/or place of business might ever be threatened by  
 17 the following hazards? Please rate what hazards present the greatest risk.

18  
 19 Low Risk = Low impact on threat to life and property damage  
 20 Medium Risk = Medium impact on threat to life and property damage  
 21 High Risk = High impact on threat to life and property damage

	Low Risk	Medium Risk	High Risk	Not Applicable
<b>Communicable Disease</b>	( )	( )	( )	( )
<b>Drought</b>	( )	( )	( )	( )
<b>Earthquake</b>	( )	( )	( )	( )
<b>Flooding</b>	( )	( )	( )	( )
<b>Dam Failure</b>	( )	( )	( )	( )
<b>Earthquake</b>	( )	( )	( )	( )
<b>Karst</b>	( )	( )	( )	( )
<b>Subsidence</b>	( )	( )	( )	( )
<b>Landslide</b>	( )	( )	( )	( )
<b>Non-Rotational Winds</b>	( )	( )	( )	( )
<b>Solar Storm</b>	( )	( )	( )	( )
<b>Tornado</b>	( )	( )	( )	( )
<b>Wildfire</b>	( )	( )	( )	( )
<b>Winter Storm</b>	( )	( )	( )	( )

22  
 23 16) Please select the answer that best describes your experience.  
 24 Minor = Repairable, non-structural damage to a home or damage from flood waters when the  
 25 waterline is 18 inches or below in a conventionally built home or when the waterline is in the  
 26 floor system of a manufactured home.



1 Major = Structural damage or other significant damage that requires extensive repairs or  
2 damage from flood waters when the waterline is 18 inches or above in a conventionally built  
3 home or when the waterline enters the living space of a manufactured home.

4 Catastrophic = Significant enough damage that the home is deemed a total loss.

5 ( ) I have never experienced property damage or loss from a disaster(s)

6 ( ) I have experienced minor property damage and loss from a disaster(s)

7 ( ) I have experienced major property damage and loss from a disaster(s)

8 ( ) I have experienced catastrophic property damage and loss from a disaster(s)

9 17) If you have experienced any damage(s) or injury(ies) from a disaster, please describe the  
10 first event:

11 What hazard caused the damages/losses and/or injuries? (Example: flooding, wind, winter  
12 storm) : \_\_\_\_\_

13 Where did the damage/loss occur? (Example: my home, on a roadway or intersection, at work,  
14 on vacation, etc.) : \_\_\_\_\_

15 Please describe the damages and/or injuries. (Example: basement flooded, roof was damaged,  
16 vehicle was damaged, broken bones, lacerations, etc.):

17 \_\_\_\_\_  
18 \_\_\_\_\_

19 18) If you have experienced any damage(s) or injury(ies) from a disaster, please describe the  
20 second event:

21 What hazard caused the damages/losses and/or injuries? (Example: flooding, wind, winter  
22 storm) : \_\_\_\_\_

23 Where did the damage/loss occur? (Example: my home, on a roadway or intersection, at work,  
24 on vacation, etc.) : \_\_\_\_\_

25 Please describe the damages and/or injuries. (Example: basement flooded, roof was damaged,  
26 vehicle was damaged, broken bones, lacerations, etc.):

27 \_\_\_\_\_

28

29 19) If you have experienced any damage(s) or injury(ies) from a disaster, please describe the  
30 damages and/or injuries.

31 What hazard caused the damages/losses and/or injuries? (Example: flooding, wind, winter  
32 storm) : \_\_\_\_\_

33 Where did the damage/loss occur? (Example: my home, on a roadway or intersection, at work,  
34 on vacation, etc.) : \_\_\_\_\_



1 Please describe the damages and/or injuries. (Example: basement flooded, roof was damaged,  
 2 vehicle was damaged, broken bones, lacerations, etc.):

3 \_\_\_\_\_

4 \_\_\_\_\_

5

6 20) Please select the best answer. The risks associated with LENOWISCO Planning District's  
 7 most prevalent hazards are:

8  increasing quickly

9  increasing slowly

10  staying the same

11  decreasing slowly

12  decreasing quickly

13  Do not know

14  Not applicable

15  Other (please specify): \_\_\_\_\_

16

17 21) Based on YOUR PERCEPTION of your jurisdiction's hazards, to what degree of emphasis  
 18 would you expect your jurisdiction to mitigate the following hazards?

19 Mitigation definition: The purpose of mitigation planning is to identify policies and actions that  
 20 can be implemented over the long term to reduce risk and future losses. Mitigation forms the  
 21 foundation for a community's long-term strategy to reduce disaster losses and break the cycle of  
 22 disaster damage, reconstruction, and repeated damage.

23

24 •**No Mitigation Needed** = No mitigation on this hazard is expected or needed

25 •**Low Priority** = This hazard should be mitigated, but is not a high priority compared to other  
 26 hazards

27 •**Medium Priority** = It is important to mitigate this hazard

28 •**High Priority** = It is a high priority to emphasize mitigation for this hazard

29

	Low Risk	Medium Risk	High Risk	Not Applicable
Communicable Disease	<input type="checkbox"/>	<input type="checkbox"/>	<input type="checkbox"/>	<input type="checkbox"/>
Drought	<input type="checkbox"/>	<input type="checkbox"/>	<input type="checkbox"/>	<input type="checkbox"/>
Earthquake	<input type="checkbox"/>	<input type="checkbox"/>	<input type="checkbox"/>	<input type="checkbox"/>
Flooding	<input type="checkbox"/>	<input type="checkbox"/>	<input type="checkbox"/>	<input type="checkbox"/>
Dam Failure	<input type="checkbox"/>	<input type="checkbox"/>	<input type="checkbox"/>	<input type="checkbox"/>



Earthquake	( )	( )	( )	( )
Karst	( )	( )	( )	( )
Subsidence	( )	( )	( )	( )
Landslide	( )	( )	( )	( )
Non-Rotational Winds	( )	( )	( )	( )
Solar Storm	( )	( )	( )	( )
Tornado	( )	( )	( )	( )
Wildfire	( )	( )	( )	( )
Winter Storm	( )	( )	( )	( )

1

2 Evacuation

3 22) If an evacuation was ordered for your area, please indicate how likely you would be to do  
 4 the following.

	Very Likely	Somewhat Likely	Not Very Likely	Not Likely at All	Do Not Know	Not Applicable
Immediately evacuate as instructed.	( )	( )	( )	( )	( )	( )
I would first consult with family and friends outside my household before making a decision to evacuate.	( )	( )	( )	( )	( )	( )
Wait and see how bad the situation is going to be before deciding to evacuate.	( )	( )	( )	( )	( )	( )
Refuse to evacuate no matter what.	( )	( )	( )	( )	( )	( )

5

6 23) What might prevent you from leaving your place of residence if there was an evacuation  
 7 order? Please select ALL that apply.

8 [ ] Pet

9 [ ] Livestock

10 [ ] Job

11 [ ] Need to care for another person

12 [ ] Spouse/Significant Other won't leave

13 [ ] Need to stay and protect property

14 [ ] Lack of money



- 1  No place to go
- 2  No transportation
- 3  Traffic
- 4  Lack of gas/fuel for vehicle
- 5  Disability/Health Issues
- 6  Other (please specify): \_\_\_\_\_
- 7  No obstacles would prevent me from evacuating
- 8  I would refuse to evacuate no matter what

9

10 24) If you were to evacuate, where would you most likely stay? Please select the best answer.

- 11  Shelter/evacuation center
- 12  Church or place of worship
- 13  Workplace
- 14  Home of a friend or relative
- 15  Hotel/motel
- 16  Do Not Know
- 17  Other (please specify): \_\_\_\_\_

18

19 25) In an evacuation, would you or anyone in your household require special assistance?

- 20  Yes
- 21  Maybe
- 22  No
- 23  Do Not Know
- 24  Not applicable
- 25  Other (please specify): \_\_\_\_\_

26

27 26) If yes, would that assistance be provided by someone within your household, by an outside agency, or by a friend or relative outside your household?

- 28  Within household
- 29  Friend/Relative (outside household)
- 30  Outside Agency
- 31  Do Not Know
- 32  Not Applicable
- 33  Other (please specify): \_\_\_\_\_

34

35

36 27) If applicable, please indicate what kind of outside assistance your household may need during an evacuation (i.e. Transportation, Medical, etc.)

37 \_\_\_\_\_

38 \_\_\_\_\_

39 \_\_\_\_\_

40 \_\_\_\_\_

41

42 Demographic Questions

- 43
- 44 28) What type of structure do you live in?
- 45  Detached single family home
- 46  Duplex, triplex, quadruple home
- 47  Multi-family building – 2 stories or more (apartment/condo)





- 1  Mobile home
- 2  Manufactured home
- 3  Recreational vehicle (RV)
- 4  Some other type of structure
- 5  Do Not Know
- 6  Not Applicable
- 7  Other (please specify): \_\_\_\_\_

- 8
- 9 29) Do you own or rent your home/place of residence?
- 10  Own
- 11  Rent
- 12  Do Not Know
- 13  Not Applicable
- 14  Other (please specify): \_\_\_\_\_

15

16 30) How many persons, including yourself, are currently living in your household?

	1	2	3	4	5	6	7	8	9	10 or more
<b>Under age 5</b>										
<b>Ages 6 - 10</b>										
<b>Ages 11 - 19</b>										
<b>Ages 20 - 44</b>										
<b>Ages 45 - 64</b>										
<b>Ages 65- 79</b>										
<b>Ages 80</b>										

- 17
- 18 31) Which of the following best describes your race/ethnicity? Please select ALL that apply.
- 19  American Indian or Alaska Native
- 20  Hawaiian or Other Pacific Islander
- 21  Asian or Asian American
- 22  Black or African American
- 23  Hispanic or Latino
- 24  Non-Hispanic White
- 25  Other (please specify): \_\_\_\_\_

- 26
- 27 32) Please indicate the language(s) spoken in your household. Please select ALL that apply.
- 28  English
- 29  Spanish
- 30  Other Indo-European language
- 31  Asian and Pacific Island language



1 [ ] Other (please specify): \_\_\_\_\_  
2

3 33) Please indicate your sex.

4 ( ) Female

5 ( ) Male

6 ( ) Not Applicable  
7

8 \_\_\_\_\_

9 Contact

10

11 34) (OPTIONAL): Would you like more information on how you can be more prepared?

12 ( ) Yes

13 ( ) No  
14

15 35) (OPTIONAL): Would you be interested in participating in a free training led by  
16 The Community Emergency Response Team (CERT) Program on disaster preparedness? More  
17 information on the CERT Program is available on the next page.

18 ( ) Yes

19 ( ) No  
20

21 36) (OPTIONAL): Would you like to be entered into the raffle for the prize?

22 ( ) Yes

23 ( ) No  
24

25 37) To receive information on LENOWISCO Planning District Emergency Management, please  
26 provide your name, e-mail, and phone number below. We will ensure your information is  
27 kept confidential.

28 Name: \_\_\_\_\_

29 Phone: \_\_\_\_\_

30 E-mail: \_\_\_\_\_  
31

32 \_\_\_\_\_

33 Thank You!

34

35 This concludes the survey. Thank you for your time!

36



## 1 A.2 Survey Results

2 The following questions were included in the public survey. Short answer responses are  
 3 excluded to protect survey respondent's personal information.

### Response Statistics

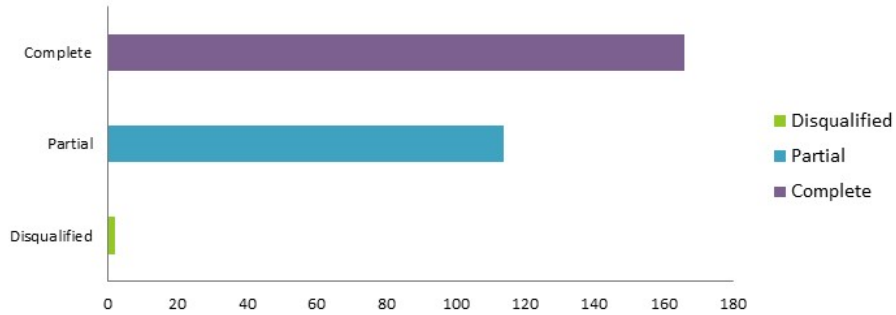

	Count	Percent
Complete	166	58.9
Partial	114	40.4
Disqualified	2	0.7
Total	282	

4

1. Do you live and/or work in the LENOWISCO Planning District? Please select all that apply.

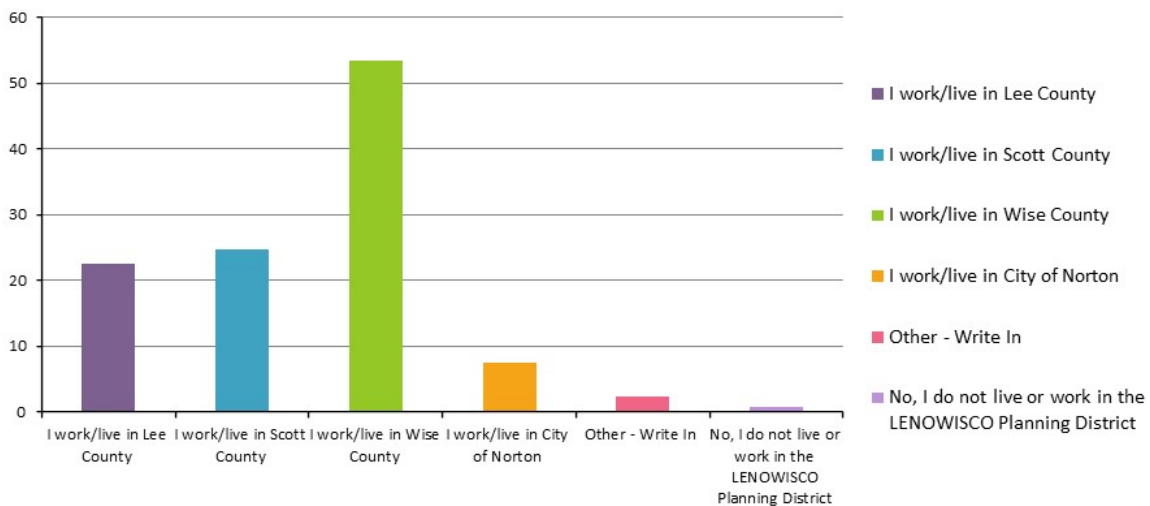

5



2. Approximately how many years have you lived in the LENOWISCO Planning District?

Value		Percent	Count
0-2 years		5.8%	14
3-5 years		2.9%	7
6-10 years		4.6%	11
11-20 years		11.2%	27
21 or more years		71.4%	172
Not Applicable		2.5%	6
Do Not Know		0.8%	2
Other (please specify)		0.8%	2
<b>Total</b>			241

1

3. Approximately how many years have you worked in the LENOWISCO Planning District?

Value		Percent	Count
0-2 years		7.1%	17
3-5 years		5.4%	13
6-10 years		10.4%	25
11-20 years		19.9%	48
21 or more years		48.1%	116
Not Applicable		7.5%	18
Do Not Know		0.8%	2
Other (please specify)		0.8%	2
<b>Total</b>			241

2



4. Please indicate which community in the LENOWISCO Planning District you live in.

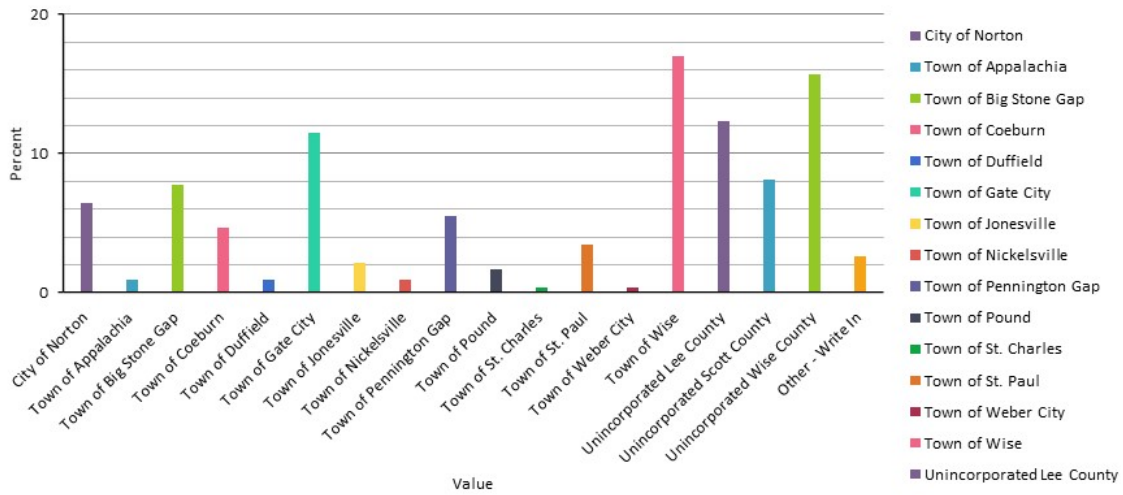

1

5. Please indicate which community in the LENOWISCO Planning District you work in.

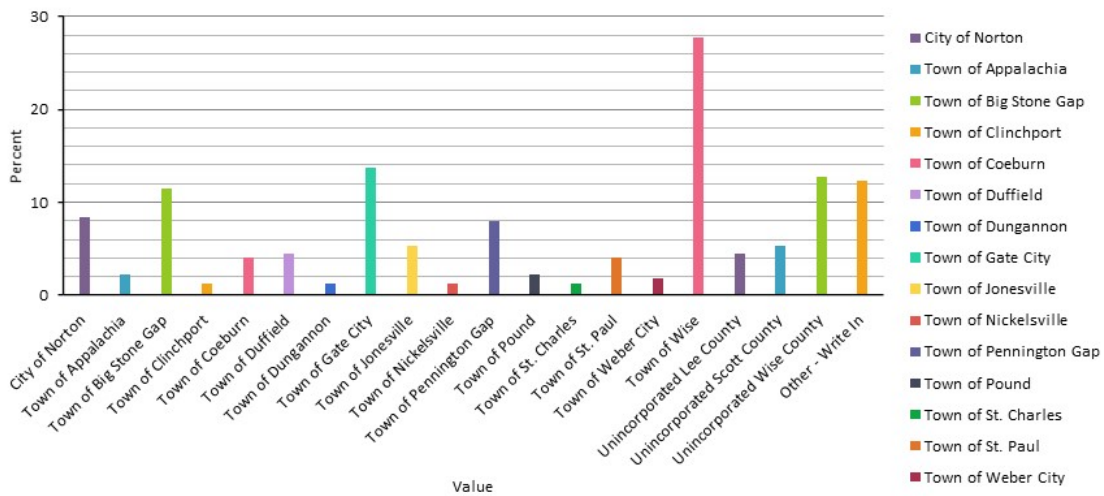

2



6. Please indicate what type of device(s) you use to access the internet. Select ALL that apply.

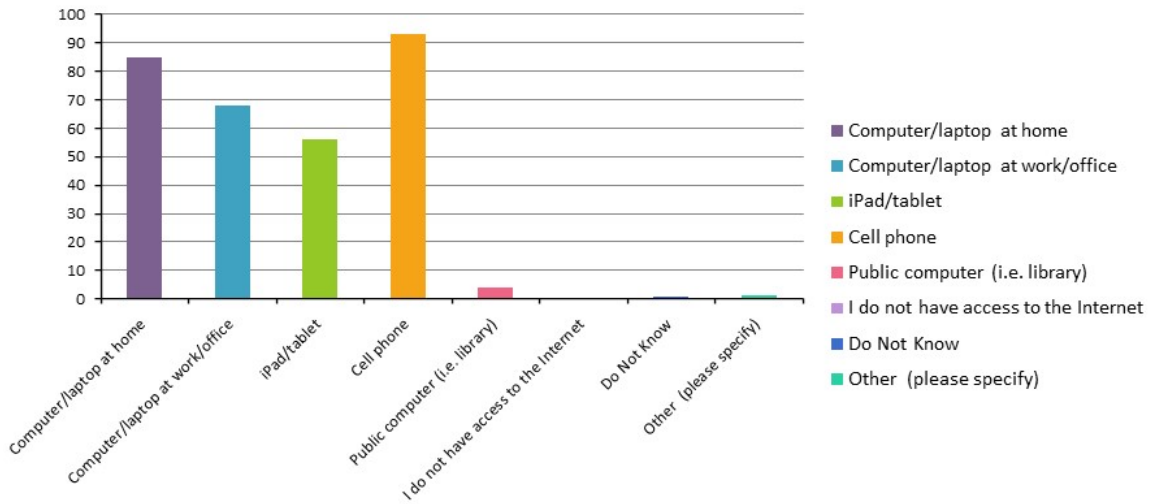

1

7. Please indicate those activities you and your family have done to prepare for emergencies and disasters. Please select ALL that apply. I have...

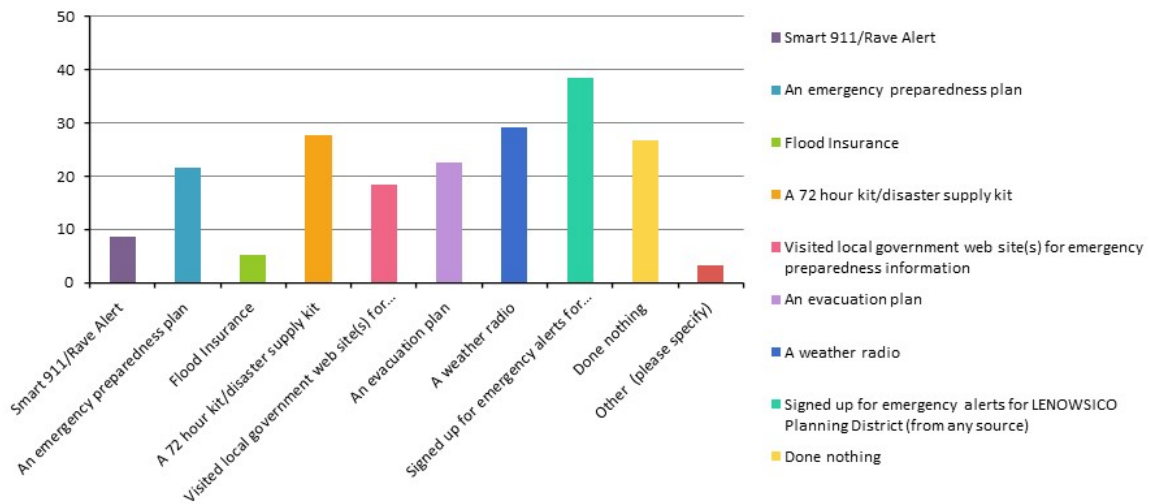

2





8. Have any of the reasons below prevented you from pursuing additional preparedness activities? Please select ALL that apply.

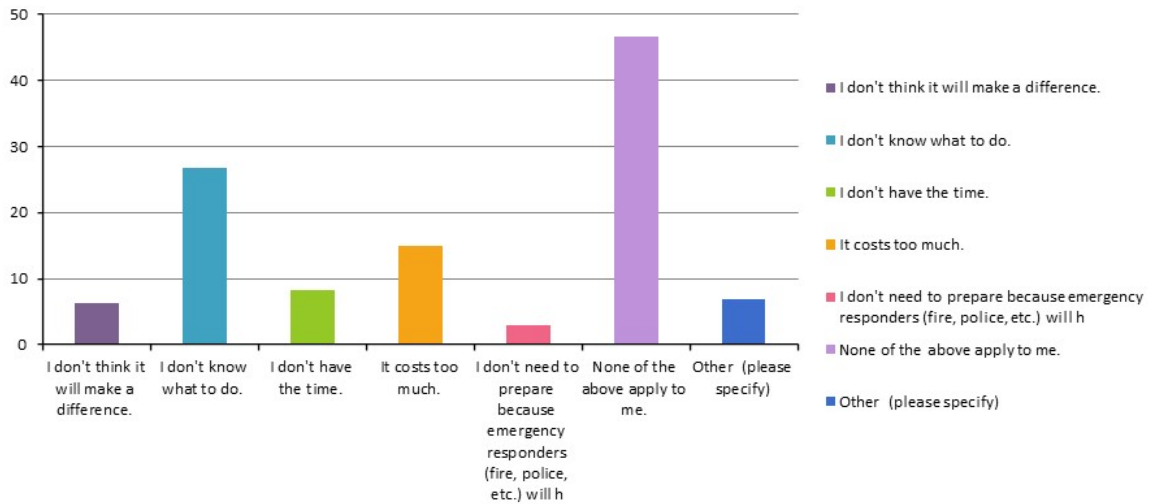

1

9. Please indicate where you go to obtain emergency and disaster preparedness related information? Please select ALL that apply.

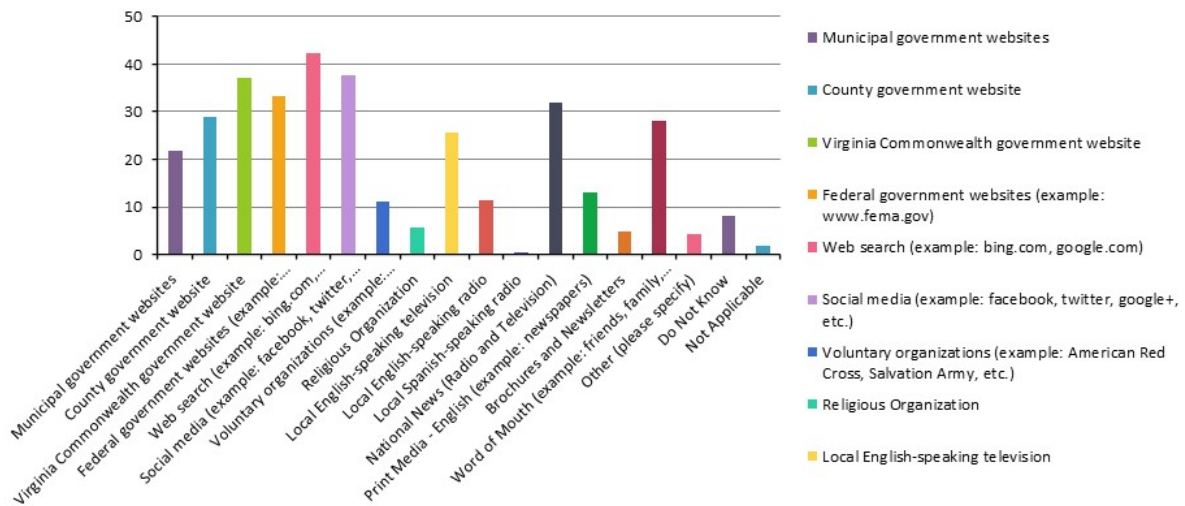

2



10. Please indicate how you expect to receive alerts and information during an emergency. Please select ALL that apply.

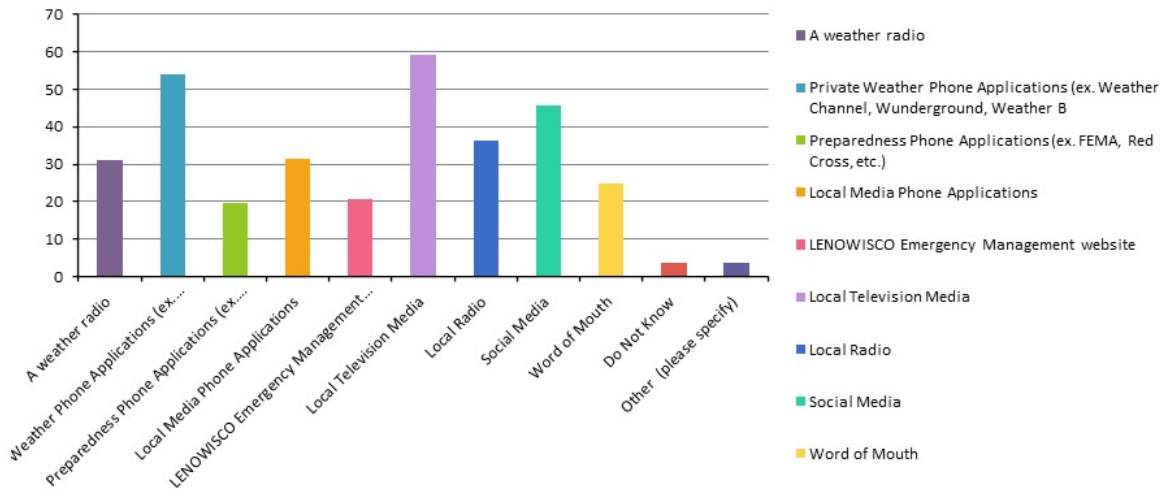

1

11. Would you agree or disagree with the following statements?

	Strongly Agree		Agree		Neither Agree nor Disagree		Disagree		Strongly Disagree		Do Not Know		Responses
	Count	Row %	Count	Row %	Count	Row %	Count	Row %	Count	Row %	Count	Row %	
My jurisdiction is providing the services necessary to prepare me for a disaster.	20	9.6%	63	30.1%	53	25.4%	26	12.4%	17	8.1%	30	14.4%	209
I am familiar with my jurisdiction's website and can easily obtain information about emergencies and disasters.	29	14.0%	71	34.3%	30	14.5%	41	19.8%	22	10.6%	14	6.8%	207
During times of emergency, information is provided in a language and format I can understand.	70	34.0%	90	43.7%	26	12.6%	3	1.5%	2	1.0%	15	7.3%	206
I can easily obtain emergency information in times of crisis.	35	16.9%	85	41.1%	36	17.4%	22	10.6%	7	3.4%	22	10.6%	207

2



13. If a disaster (i.e. snowstorm) impacted your community, knocking out electricity and running water, would your household be able to manage on its own for at least three (3) days?

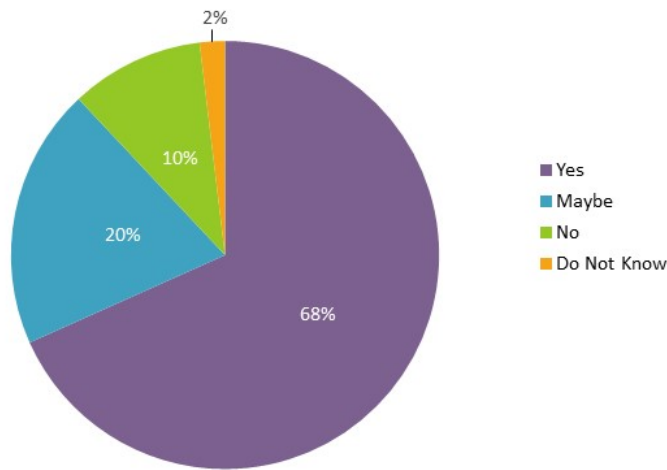

1

14. Which of the following may prevent you from recovering from a disaster? Please select ALL that apply.

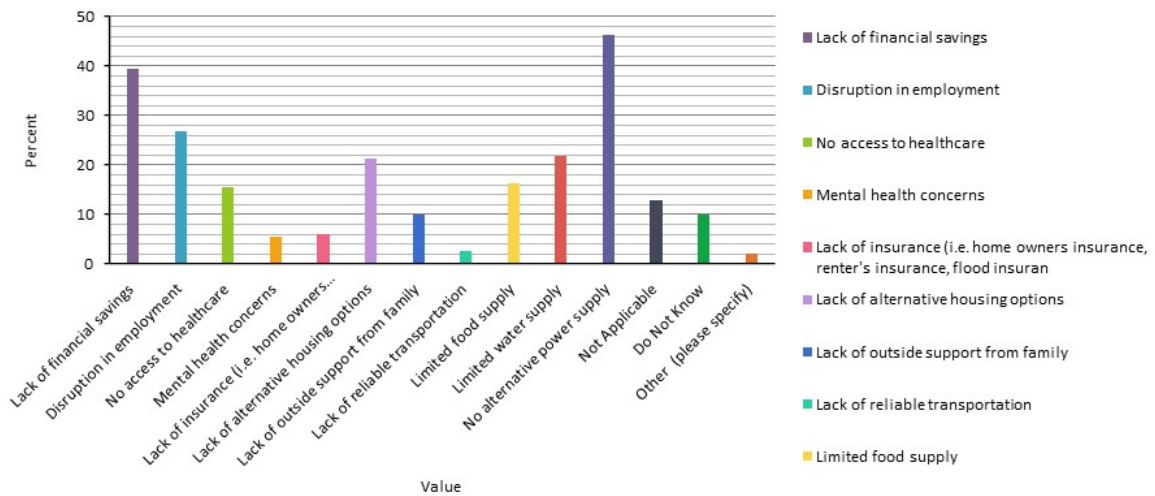

2



15. Do you believe that your household and/or place of business might ever be threatened by the following hazards? Please rate what hazards present the greatest risk. Low Risk = Low impact on threat to life and property damage; Medium Risk = Medium impact on threat to life and property damage; High Risk = High impact on threat to life and property damage

	Low Risk		Medium Risk		High Risk		Not Applicable		Responses Count
	Count	Row %	Count	Row %	Count	Row %	Count	Row %	
Communicable Disease	35	20.5%	63	36.8%	71	41.5%	2	1.2%	171
Drought	91	53.5%	65	38.2%	9	5.3%	5	2.9%	170
Earthquake	128	74.9%	32	18.7%	8	4.7%	3	1.8%	171
Flooding	74	43.3%	63	36.8%	31	18.1%	3	1.8%	171
Dam Failure	127	74.3%	21	12.3%	4	2.3%	19	11.1%	171
Karst	97	58.4%	22	13.3%	5	3.0%	42	25.3%	166
Subsidence	101	60.8%	35	21.1%	8	4.8%	22	13.3%	166
Landslide	103	60.2%	48	28.1%	11	6.4%	9	5.3%	171
Non-Rotational Winds	66	38.8%	79	46.5%	22	12.9%	3	1.8%	170
Solar Storm	114	68.3%	36	21.6%	3	1.8%	14	8.4%	167
Tornado	74	43.3%	86	50.3%	9	5.3%	2	1.2%	171
Wildfire	76	44.2%	67	39.0%	26	15.1%	3	1.7%	172
Winter Storm	5	2.9%	75	43.9%	89	52.0%	2	1.2%	171

1

16. Please select the answer that best describes your experience.

Minor = Repairable, non-structural damage to a home or damage from flood waters when the waterline is 18 inches or below in a conventionally built home or when the waterline is in the floor system of a manufactured home.

Major = Structural damage or other significant damage that requires extensive repairs or damage from flood waters when the waterline is 18 inches or above in a conventionally built home or when the waterline enters the living space of a manufactured home.

Catastrophic = Significant enough damage that the home is deemed a total loss.



2



20. Please select the best answer. The risks associated with LENOWSICO Planning District's most prevalent hazards are:

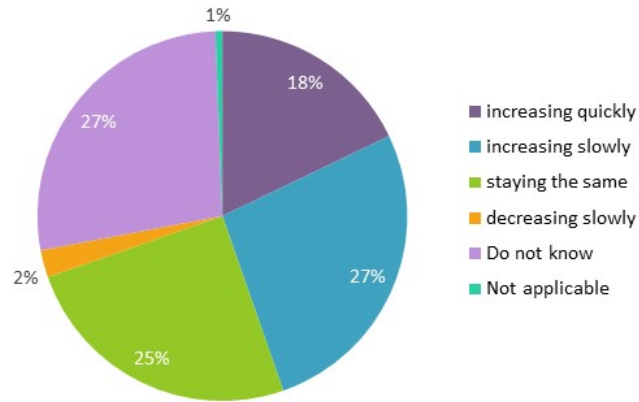

1

21. Based on YOUR PERCEPTION of your jurisdiction's hazards, to what degree of emphasis would you expect your jurisdiction to mitigate the following hazards?  
 Mitigation: The purpose of mitigation planning is to identify policies and actions that can be implemented over the long term to reduce risk and future losses. Mitigation forms the foundation for a community's long-term strategy to reduce disaster losses and break the cycle of disaster damage, reconstruction, and repeated damage. No Mitigation Needed = No mitigation on this hazard is expected or needed  
 Low Priority = This hazard should be mitigated, but is not a high priority compared to other hazards  
 Medium Priority = It is important to mitigate this hazard  
 High Priority = It is a high priority to emphasize mitigation for this hazard

	No Mitigation Needed		Low Priority		Medium Priority		High Priority		Do not know		Responses
	Count	Row %	Count	Row %	Count	Row %	Count	Row %	Count	Row %	
Communicable Disease	8	4.8%	16	9.6%	46	27.5%	91	54.5%	6	3.6%	167
Drought	24	14.5%	79	47.6%	46	27.7%	9	5.4%	8	4.8%	166
Earthquake	47	28.3%	78	47.0%	25	15.1%	9	5.4%	7	4.2%	166
Flooding	6	3.6%	22	13.3%	74	44.6%	59	35.5%	5	3.0%	166
Dam Failure	42	25.3%	61	36.7%	37	22.3%	13	7.8%	13	7.8%	166
Karst	42	25.6%	48	29.3%	25	15.2%	4	2.4%	45	27.4%	164
Subsidence	35	21.6%	56	34.6%	27	16.7%	12	7.4%	32	19.8%	162
Landslide	21	12.7%	64	38.8%	52	31.5%	22	13.3%	6	3.6%	165
Non-Rotational Winds	11	6.6%	63	38.0%	68	41.0%	12	7.2%	12	7.2%	166
Solar Storm	49	29.7%	72	43.6%	16	9.7%	5	3.0%	23	13.9%	165
Tornado	10	6.0%	74	44.6%	53	31.9%	24	14.5%	5	3.0%	166
Wildfire	9	5.4%	44	26.3%	73	43.7%	36	21.6%	5	3.0%	167
Winter Storm	1	0.6%	12	7.2%	62	37.1%	86	51.5%	6	3.6%	167

2



22.If an evacuation was ordered for your area, please indicate how likely you would be to do the following.

	Very Likely		Somewhat Likely		Not Very Likely		Not Likely at All		Do Not Know		Not Applicable		Responses Count
	Count	Row %	Count	Row %	Count	Row %	Count	Row %	Count	Row %	Count	Row %	
Immediately evacuate as instructed.	66	39.5%	68	40.7%	19	11.4%	8	4.8%	5	3.0%	1	0.6%	167
I would first consult with family and friends outside my household before making a decision to evacuate.	57	35.4%	57	35.4%	22	13.7%	21	13.0%	3	1.9%	1	0.6%	161
Wait and see how bad the situation is going to be before deciding to evacuate.	21	13.0%	68	42.0%	41	25.3%	27	16.7%	4	2.5%	1	0.6%	162
Refuse to evacuate no matter what	3	1.9%	5	3.1%	37	23.1%	100	62.5%	10	6.3%	5	3.1%	160

1

23.What might prevent you from leaving your place of residence if there was an evacuation order? Please select ALL that apply.

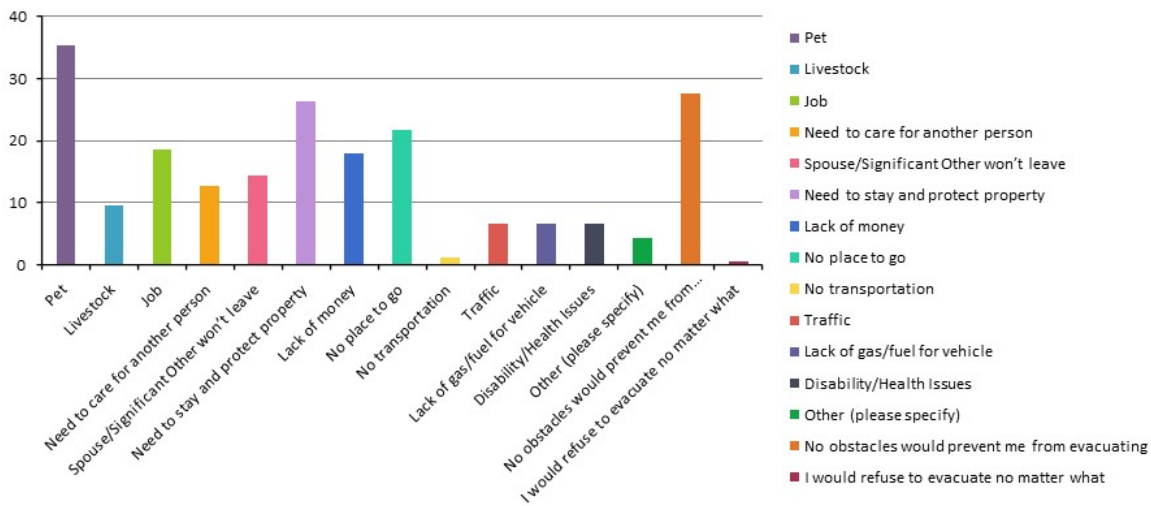

2





24.If you were to evacuate, where would you most likely stay? Please select the best answer.

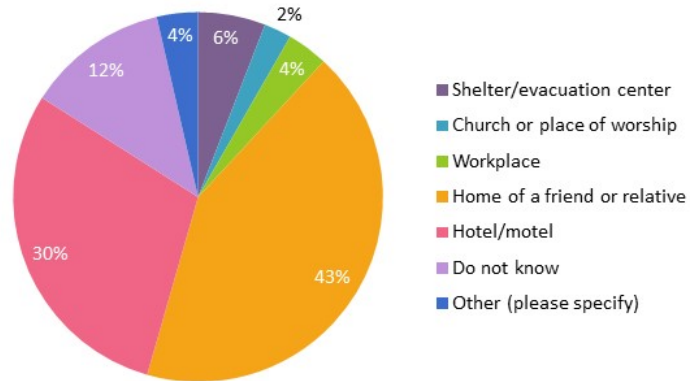

1

25.In an evacuation, would you or anyone in your household require special assistance?

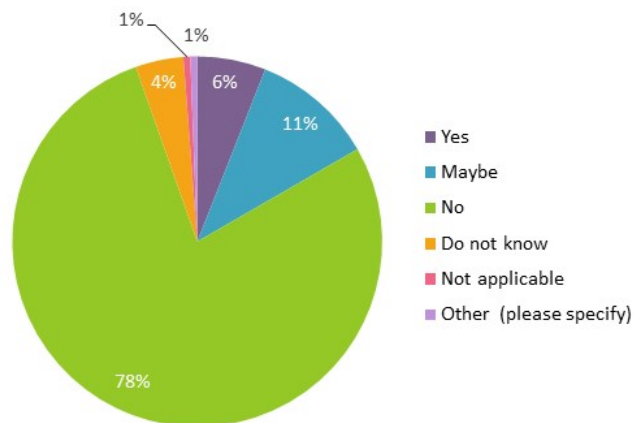

2



26.If yes, would that assistance be provided by someone within your household, by an outside agency, or by a friend or relative outside your household?

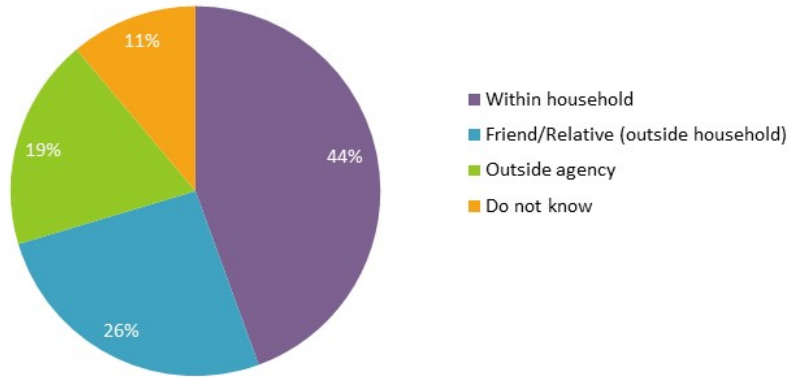

1

28.What type of structure do you live in?

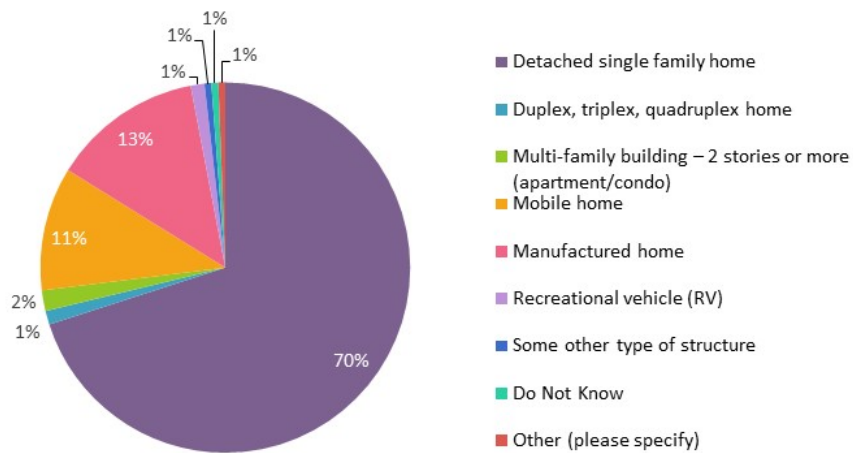

2



### 29. Do you own or rent your home/place of residence?

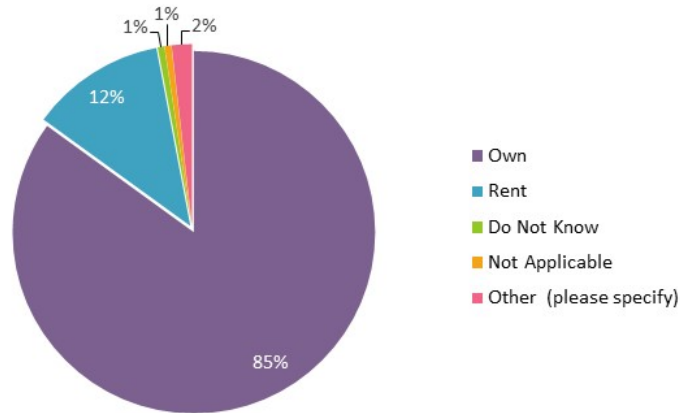

1

### 30. How many persons, including yourself, are currently living in your household?

	1	2	3	4	5	6	7	8	9	10 or more	Responses
	Row % Count	Row % Count	Row % Count	Row % Count	Row % Count	Row % Count	Row % Count	Row % Count	Row % Count	Row % Count	
Under age 5	66.7% 8	16.7% 2	0.0% 0	8.3% 1	0.0% 0	0.0% 0	0.0% 0	0.0% 0	0.0% 0	8.3% 1	12
Ages 6 - 10	90.9% 20	9.1% 2	0.0% 0	0.0% 0	0.0% 0	0.0% 0	0.0% 0	0.0% 0	0.0% 0	0.0% 0	22
Ages 11 - 19	65.9% 29	22.7% 10	11.4% 5	0.0% 0	0.0% 0	0.0% 0	0.0% 0	0.0% 0	0.0% 0	0.0% 0	44
Ages 20 - 44	53.4% 39	45.2% 33	1.4% 1	0.0% 0	0.0% 0	0.0% 0	0.0% 0	0.0% 0	0.0% 0	0.0% 0	73
Ages 45 - 64	46.9% 46	53.1% 52	0.0% 0	0.0% 0	0.0% 0	0.0% 0	0.0% 0	0.0% 0	0.0% 0	0.0% 0	98
Ages 65-79	62.0% 31	38.0% 19	0.0% 0	0.0% 0	0.0% 0	0.0% 0	0.0% 0	0.0% 0	0.0% 0	0.0% 0	50
Ages 80+	80.0% 4	0.0% 0	0.0% 0	0.0% 0	0.0% 0	0.0% 0	0.0% 0	0.0% 0	0.0% 0	20.0% 1	5
<b>Total</b>											<b>304</b>

2



31. Which of the following best describes your race/ethnicity? Please select ALL that apply.

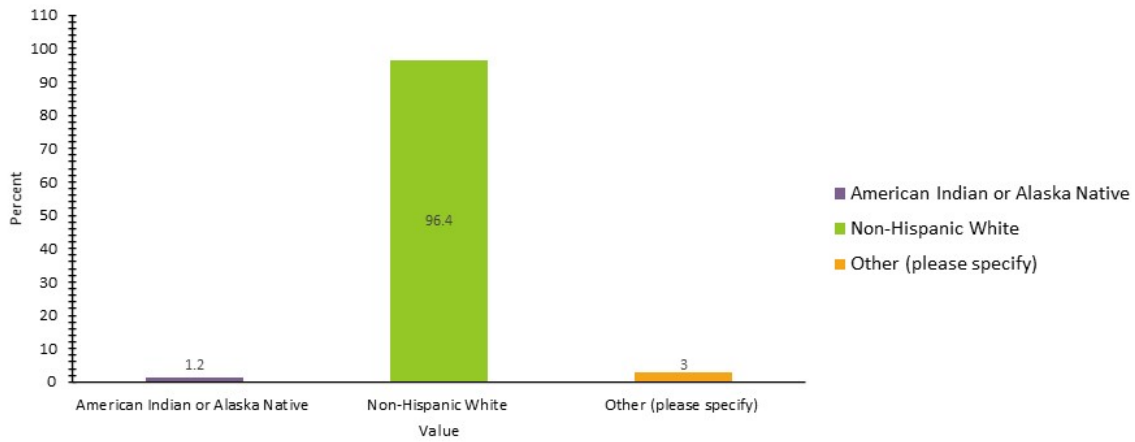

1

32. Please indicate the language(s) spoken in your household. Please select ALL that apply.

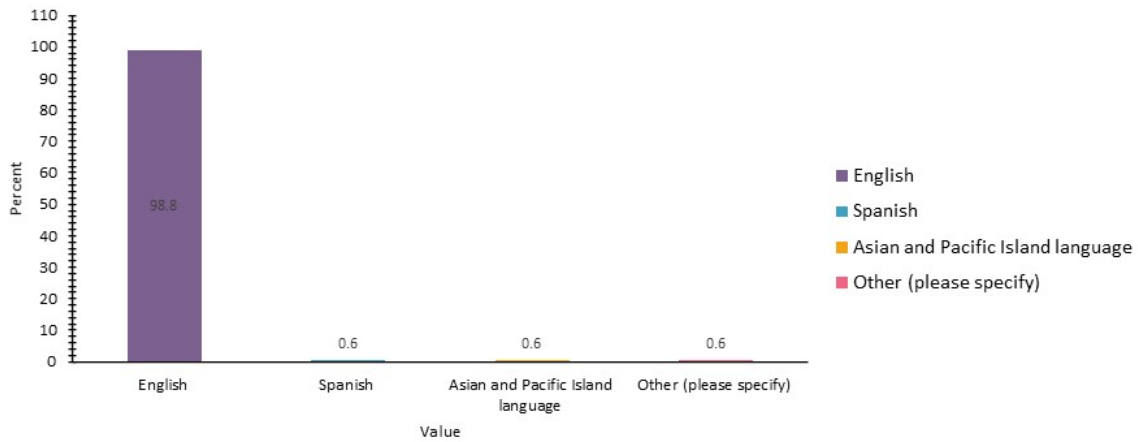

2



33. Please indicate your sex.

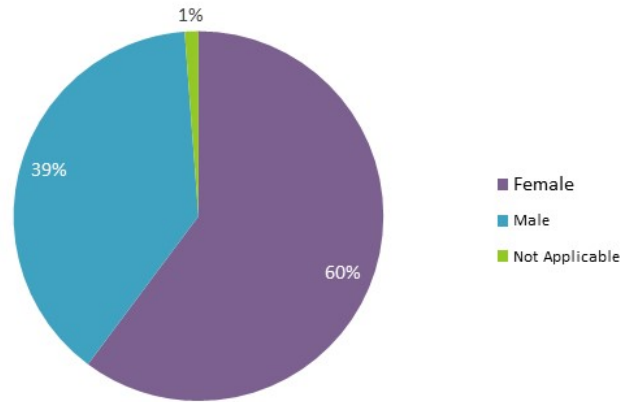

1

34.(OPTIONAL): Would you like more information on how you can be more prepared?

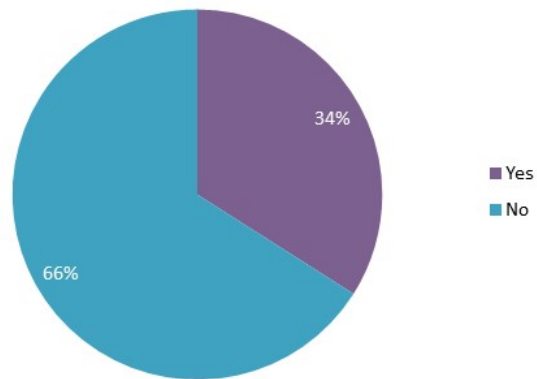

2

3



## 1 A.3 Press Releases

- 2 Below are the invite and the press release that was sent to community stakeholders and media  
3 sources to promote the Community Preparedness Survey and Hazard Mitigation Plan Review.  
4 Following these images are examples of the advertisement that went out to the community.

# LENOWISCO

## PLANNING DISTRICT COMMISSION

**FOR IMMEDIATE RELEASE**  
**January 22, 2021**

Contact: Duane Miller, Executive Director  
Telephone: (276) 431-2206  
Cell: (276) 275-6037  
Email: [dmiller@lenowisco.org](mailto:dmiller@lenowisco.org)  
Website: [www.lenowisco.org](http://www.lenowisco.org)

**LENOWISCO District Residents Invited to  
Provide Feedback on Regional Hazard Mitigation Plan Draft**

DUFFIELD – January 22, 2021 – The LENOWISCO Planning District Commission (PDC) has been working with Integrated Solutions Consulting to update the district’s comprehensive hazard mitigation plan, and is pleased to present the update’s full draft. The plan details the hazards and risks that can impact the jurisdictions in the LENOWISCO planning district, and strategies to mitigate these hazards.

Residents and the business community are invited to review and provide feedback on the updated hazard mitigation plan. There are two ways to provide feedback. The first is to attend the virtual Hazard Mitigation Plan Public Review meeting:

- Date: Thursday, February 18, 2021 5:30 PM - 6:30 PM (EST)
- Link: <https://global.gotomeeting.com/join/704346813>
  - Please note you do not need to download the application and can paste the link into a browser
- Call-in Line: +1 (872) 240-3212
- Call-in Line Access Code: 704-346-813

PDC officials encourage district residents to take advantage of this opportunity to share ideas how the LENOWISCO jurisdictions – City, Counties, and Towns – might better prepare for disasters and emergencies. Citizen and business input is viewed as essential. The feedback provided will help the planning team finalize the Hazard Mitigation Plan update. During this meeting, highlights of the plan will be shared, and time will be provided for the public to ask questions and provide feedback.

Following the meeting, the updated Hazard Mitigation Plan will be open for public comment through February 25<sup>th</sup> on the LENOWISCO website.

Those with questions may contact Frank Kibler, LENOWISCO Senior Planner, at (276) 431-2206.

Established in 1969, the LENOWISCO Planning District Commission is authorized under the Virginia Regional Cooperation Act to serve as one of 21 planning district commissions in the Commonwealth of Virginia. LENOWISCO serves the Counties of Lee, Scott, and Wise, and the City of Norton.

###



372 Technology Trail Lane, Suite 101 • Duffield VA 24244  
Phone (276) 431-2206 • Fax (276) 431-2208  
[LENOWISCO@LENOWISCO.org](mailto:LENOWISCO@LENOWISCO.org) • [www.LENOWISCO.org](http://www.LENOWISCO.org)

*Virginia Planning District One • Serving Lee-Norton-Wise-Scott*







1

townofwise.net



HOME GOVERNANCE

Click on the picture above to learn more about

## The Place To Be In Southwest

The LENOWISCO Planning District is conducting a study to better understand the emergency preparedness needs and risk perceptions of its residents as part of the Hazard Mitigation Plan update process. To do so, a questionnaire has been distributed throughout the Planning District, and your participation is requested.

The questionnaire should take about **10** minutes to complete. All responses will be kept confidential, and your participation is strictly voluntary. Your input will enable the Planning District to better serve you in times of disaster.

To participate, please click the following link:  
<https://survey.alchemer.com/s3/5952833/LENOWISCO-Community-Preparedness-Survey>

**Survey Completion Date:** Please complete the survey by January 31, 2021.

**CONTACT US:** If you have any questions, please contact:  
Frank W. Kibler  
Senior Planner  
LENOWISCO Planning District Commission  
372 Technology Trail Lane, Suite 101  
Duffield VA 24244  
fkibler@lenowisco.org

2



lenowisco.org



**The next LENOWISCO Board of Directors Meeting will be held on  
February 1, 2021 at 5:30 p.m.**

Click [Here](#) for the Round Four LENOWISCO Regional Small Business Recovery Assistance Grant Program Application

On behalf of our district localities, LENOWISCO is presently updating its regional hazard mitigation plan. Part of that effort involves soliciting public input, via the survey link below. Your participation would be greatly appreciated!

<https://survey.alchemer.com/s3/5952833/LENOWISCO-Community-Preparedness-Survey>

Established in 1969, the LENOWISCO Planning District Commission is authorized under the Virginia Regional Cooperation Act to serve as one of the twenty-one planning district commissions in the Commonwealth of Virginia. LENOWISCO serves the Counties of Lee, Scott, Wise and the City of Norton.

The Commission is recognized by the Appalachian Regional Commission as an ARC Local Development District and by the Economic Development Administration as an Economic Development District. LENOWISCO has been heavily involved in local infrastructure planning and development. Emphasis has been placed on Community Development, Economic Development, Transportation and Public Utility Infrastructure. We pride ourselves on adjusting to the changing needs of our region.

**Tweets** by @lenowisco

 **LENOWISCO PDC** @lenowisco  
#strongertogether  
<https://twitter.com/WillHPayne/status/1349484293878382596>

 **LENOWISCO PDC** @lenowisco  
On behalf of our district localities, LENOWISCO is presently updating its regional hazard mitigation plan. Part of that effort involves soliciting public input, via the survey link below. Your participation would be greatly appreciated!  
[survey.alchemer.com/s3/5952833/LEN...](https://survey.alchemer.com/s3/5952833/LEN...)





1



**LENOWISCO PDC** @lenowisco · Jan 13

On behalf of our district localities, LENOWISCO is presently updating its regional hazard mitigation plan. Part of that effort involves soliciting public input, via the survey link below. Your participation would be greatly appreciated!

[survey.alchemer.com/s3/5952833/LEN...](https://survey.alchemer.com/s3/5952833/LEN...)

   5 

2

Scott County Virginia Star • 1/27/21

**BE PREPARED.**

How prepared are you? Natural disasters can happen within a moment's notice and can leave you and your family feeling helpless if you don't have an effective plan in place.

LENOWISCO Planning District is conducting a study to better understand the preparedness needs and risk perceptions of its residents as part of the Hazard Mitigation Plan update process. Help them provide you with the tools and information necessary to help you and your loved ones reduce risk and loss by completing this survey. Your feedback is greatly needed and appreciated! You can find the survey on the Gate City, VA Facebook Page or at: <https://survey.alchemer.com/s3/59529391/LENOWISCO-Community-Preparedness-Survey>

The survey must be completed by January 31st.

Town of GATE CITY  
mygatecity.com

## LENOWISCO District Residents Invited to Provide Feedback on Hazard Mitigation Plan Draft

The LENOWISCO Planning District Commission (PDC) has been working with Integrated Solutions Consulting to update the district's comprehensive hazard mitigation plan and is ready to present the update's full draft.

The plan details the hazards and risks that can impact the jurisdictions in the LENOWISCO planning district and strategies to mitigate these hazards.

Residents and the business community are invited to review and provide feedback on the updated hazard mitigation plan. There are two ways to provide feedback.

A virtual Hazard Mitigation Plan Public Review meeting is set for Thursday, Feb. 18, from 5:30 to 6:30 p.m.

Visit <https://global.gotomeeting.com/join/704346813> to join the virtual meeting online. You do not need to download the application and can paste the web address into your browser.

You can also call into the meeting at (872) 240-4212 and use the access code of 704346813.

Officials encourage district residents to take advantage of this opportunity to share ideas how the LENOWISCO jurisdictions – city, counties and towns – might better prepare for disasters and emergencies. Citizen and business input is viewed as essential.

Feedback provided will help the planning team finalize the Hazard Mitigation Plan update. During this meeting, highlights of the plan will be shared and time will be provided for the public to ask questions and provide feedback.

Following the meeting, the updated Hazard Mitigation Plan will be open for public comment through Feb. 25 on the LENOWISCO website.

Those with questions may contact Frank Kehler, LENOWISCO Senior Planner, at 431-2206.









to extend until  
2021 the provi-  
p to 80 hours of  
ne to employees  
ied or isolated  
VID-19 exposure  
on. The provision  
datory under fed-  
through the end of  
optional for the  
ter of 2021.  
then recessed to  
February 2 for  
s for 911 Director  
munity Develop-  
ector candidates.

taxes and fees should be  
included in one check made  
payable to the Lee County  
Treasurer.  
Other options include  
credit cards (Visa, Master  
Card, Discover) as well as  
debit cards. Internet pay-  
ments can be conducted at  
[https://ipn.payments.com/  
otp/stde/lcv](https://ipn.payments.com/otp/stde/lcv).  
Pay by phone is available  
at 1-866-789-3527 with in-  
structions prompting the  
caller. There is a 2.4 percent  
fee for payment by credit/

vent Department of Motor  
Vehicle Stops which add  
an additional \$25 fee to  
remove it. It will also pre-  
vent 2019 Real Estate taxes  
from being turned over to  
TACS, which will add at a  
minimum an additional 20  
percent to the taxes that  
are already owed.

The notice also stated  
that dog tags, pursuant to  
the State Code of Virginia,  
requires all dogs must be  
vaccinated for rabies by the  
time they are four months  
old. Pricing for dog tags  
are as follows: one year  
\$2; three years \$6; and one  
year kennel (20 dogs) \$15  
with a minimum of eight  
vaccination certificates.

Payment for dog tags  
can also be mailed to the  
Lee County Treasurer, P.

## Feedback On Regional Hazard Mitigation Plan Draft

The LENOWISCO Plan-  
ning District Commission  
(PDC) has been working  
with Integrated Solutions  
Consulting to update the  
district's comprehensive  
hazard mitigation plan,  
and will present the up-  
date's full draft. The plan  
details the hazards and  
risks that can impact the  
jurisdictions in the LE-  
NOWISCO planning dis-  
trict, and strategies to  
mitigate these hazards.

Residents and the busi-  
ness community are in-  
vited to review and provide  
feedback on the updated  
hazard mitigation plan.  
There are two ways to pro-  
vide feedback: the first is  
to attend the virtual Haz-  
ard Mitigation Plan public  
review meeting on Thurs-  
day, February 18, 5:30  
p.m. - 6:30 p.m. or via a  
link which is available at  
[https://global.gotomeeting.  
com/join/704346813](https://global.gotomeeting.com/join/704346813).

Participants do not need  
to download the applica-  
tion and can paste the link  
into a browser.

The call-in Line is 1  
(872) 240-3212 with the  
access code 704-346-813.

PDC officials encourage  
district residents to take  
advantage of this oppor-  
tunity to share ideas how  
the LENOWISCO juris-  
dictions - city, counties,  
and towns - might better  
prepare for disasters and  
emergencies.

Citizen and business in-  
put is viewed as essential.  
The feedback provided will  
help the planning team fi-  
nalize the Hazard Mitiga-  
tion Plan update. During  
this meeting, highlights  
of the plan will be shared,  
and time will be provided  
for the public to ask ques-  
tions and provide feed-  
back.

Following the meet-  
ing, the updated Hazard  
Mitigation Plan will be  
open for public comment  
through February 25 on the  
LENOWISCO website.

Those with questions  
may contact Frank Kibler,  
LENOWISCO Senior  
Planner, at (276) 431-  
9996

with the Pioneers  
off the District  
Ewing, 67-64.

In a second 1  
ing that will la  
the memory of tl  
Walker faithfu  
point guard Ca  
torched the Spar  
game-high 32-pc  
sophomore back  
Cameron Grabe  
gether the most i  
performance of  
career with 15 m  
Add in 13 p  
a whopping sev  
from junior for  
Kidwell and a 2-  
half flurry, and  
recipe for a Thom  
upset victory over  
ily-favored Spart

It took quite a  
for TW (4-5, 3-4;  
rhythm in the e  
mostly due to t  
plications on the  
side of the floor.  
Eli McCoy regul  
himself around t  
in the first 16 r  
play, securing 7  
field goals in th  
half.

In fact, of the  
25 made shots  
floor, the first 14

## Virtual Transfer Fair On Februar

Mountain Em  
munity College i  
ing with other 1  
munity colleges  
Virtual Transfer  
Wednesday, Feb  
from 11 a.m. to 4

The purpose of  
to allow students  
and other individ  
ested in gaining  
tion from variou  
tions the opportu  
so in one place.  
tatives from mor  
institutions will  
gram options, se  
opportunities an  
ments for transfe

Participants ar  
aged to meet wit  
institutions to en  
make the best  
when it comes  
transfer education  
ister for the ev  
[www.mecc.edu/tr](http://www.mecc.edu/tr)

For more inform  
MECC's Transfer  
please contact Be  
Career and Trans  
selor, at 276-523

# Print Rates Down? Click.

**HOP**  
rison

**rdjones.com**  
ington Gap, VA 24277.

Member SIRP

A Century of Service  
**POWELL VALLEY NEWS**  
(USPS 4408-8000)  
Published each Wednesday by  
**POWELL VALLEY  
PRINTING COMPANY**  
41798 East Morgan Avenue  
Pennington Gap, VA 24277  
Phone 276-546-1210  
FAX 276-546-5468

Rick Watson, Publisher  
Patricia Ewing, Office Manager

Periodicals Postage Paid at  
Pennington Gap, VA 24277

**POSTMASTER:**  
Send address corrections to:  
Powell Valley News  
P. O. Box 459  
Pennington Gap, VA 24277

**Subscription Rates:**  
Lee, Scott, Wise Counties  
one year-\$30.00; two  
years-\$59.00  
Payable in Advance  
Outside Lee County  
one year-\$35.00; two  
years-\$69.00  
Payable in Advance

**Obituaries** are \$25.00  
10 inches or less  
\$7.00 for each additional inch  
1 Column Photo, Add'l \$10.00  
Payable in Advance

**Card of Thanks** are \$15.00  
Payable in Advance

**IN MEMORIAMs**  
Twenty cents per word  
1 Column Photo - \$10.00  
Payable in Advance

**Classified Advertising**



1 **A.4 Sign-in Sheets**

<b>TABLE: LENOWISCO Hazard Mitigation Meeting Attendees</b>	
<b>Summary</b>	
<b>Meeting Date</b>	<b>Meeting Duration</b>
<b>October 8, 2020 12:45 PM CDT</b>	<b>94 minutes</b>
<b>Details</b>	
<b>Name</b>	<b>Email Address</b>
+12762193477	
+12763282360	
+12763467703	
+12763467791	
+12767822622	
+19542456628	
Alan Bailey	abailey@lee911.org
Betsy Lopez	
Cassandra Wolff - ISC	cassandra.wolff@i-s-consulting.com
Dane Poe	
Earl Carter Town of St. Paul	
Edward Wolff - ISC	ed.wolff@i-s-consulting.com
Frank K	
Fred Ramey	fredr@nortonva.org
Freda Starnes	fstarnes@scottcountyva.com
Greg Jones	
Harrington, Sara	
Jessica Swinney	
Laura Craft	
Leah Rausch (ISC)	
Matt Stanley	
Stephen McElroy	scmcelroy@nortonva.org
Todd Lagow	Toddl@nortonva.org

2

3





**TABLE: LENOWISCO Hazard Mitigation Meeting Attendees**

<b>Summary</b>	
<b>Meeting Date</b>	<b>Meeting Duration</b>
December 16, 2020 9:45 AM CST	72 minutes
<b>Details</b>	
<b>Name</b>	<b>Email Address</b>
+12763467703	
+12763863611	
+12763932481	
+12763951136	
+12764312206	
+12765230115	
+12766906188	
+12766987699	
+12767965188	
+19542456628	
Betsy Lopez	
Brian Skidmore	
Cassandra Wolff - ISC	cassandra.wolff@i-s-consulting.com
Dane Poe	
Earl Carter Town of St. Paul	
Frank Kibler	
Greg Jones	
Jeff.Brickey	
Jessica Swinney	gio@wisecounty.org
Laura Craft	
Leah Rausch	leah.rausch@i-s-consulting.com
Matt Stanley	matt.stanley@i-s-consulting.com
Matthew Bright	
Stephen Lawson	
Stephen McElroy	scmcelroy@nortonva.org
Todd Lagow	toddl@nortonva.org

1

2



<b>TABLE: Jurisdiction Hazard, Mitigation, and Capability Assessment Meetings</b>		
<b>Jurisdiction</b>	<b>Stakeholder(s) on Call</b>	<b>Meeting Date and Time</b>
Scott County	Jeff Brickey	1/6/2021 2-3 PM (CT)
Town of Coeburn	Jimmy Williams	1/8/2021 3-4 PM (CT)
Town of Pennington Gap	Brian Skidmore	1/11/21 8-9 AM (CT)
Town of Wise	Laura Roberts	1/11/21 9-10 AM (CT)
Wise County	Jessica Swinney	1/13/21 9-10 AM (CT)
Town of Gate City	Greg Jones	1/20/21 9-10 AM (CT)
Lee County	Dane Poe	1/20/21 1-2 PM (CT)
Town of Pound	Jane Bennett	1/21/21 2-3 (CT)
Norton	Todd Lagow	1/25/21 12-1 PM (CT)
St. Paul	Earl Carter	1/28/21 2:30-3:30 PM (CT)
Town Big Stone Gap	Matthew Bright	2/1/21 9-10 AM (CT)

1

DRAFT